



# Lead-Free Current Sensing Resistors

## RLS Series

### ( Halogen-Free )

Document No	TRLS-XX0S001K
Issued date	2017/03/01
page	1/8

### 1. Scope :

This specification applied to the products of Lead-Free current sensing resistor of metal foil for Lead-Free RLS series manufactured by TA-I TECHNOLOGY CO.,LTD.

### 2. Type Designation :

Series No.	Tolerance	Packaging	Power	Resistance
<b>RLS12</b> 06→0603 10→0805 12→1206 25→2512	<b>F</b> F = ± 1% G = ± 2% J = ± 5%	<b>T</b> T=Paper E=Embossed	<b>C</b> A = 0.25W S = 0.5 W I = 0.75W C = 1 W E = 2W	<b>R010</b> R005=5 mΩ R0065=6.5 mΩ R010=10mΩ

### 3. Dimension :

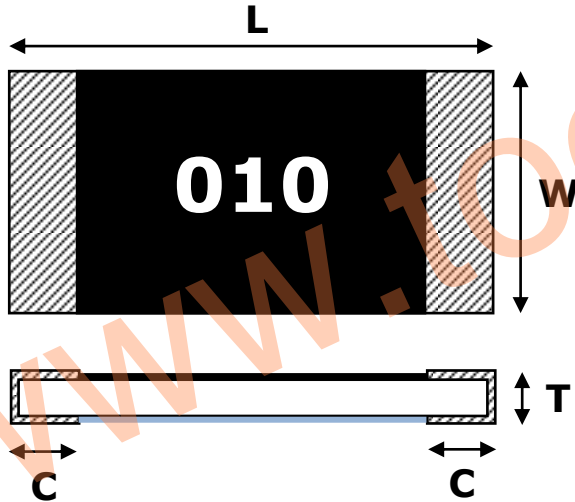

#### 3.1 Marking

For 0805 to 2512:

Resistance value is expressed by 3 digits.

E.G.:

$$005 = 0.005 \Omega = 5 \text{ m}\Omega$$

$$010 = 0.010 \Omega = 10 \text{ m}\Omega$$

$$6.5 = 0.0065 \Omega = 6.5 \text{ m}\Omega$$

For 0603: No Marking.

UNIT: mm

Series	L	W	C	T
RLS06	1.60±0.20	0.80±0.20	0.40±0.20	0.60±0.20
RLS10	2.00±0.20	1.25±0.20	0.40±0.30	0.70±0.20
RLS12	3.20±0.20	1.60±0.20	0.50±0.30	0.70±0.20
RLS25	6.40±0.20	3.20±0.20	0.90±0.20	0.70±0.20



# Lead-Free Current Sensing Resistors RLS Series ( Halogen-Free )

Document No	TRLS-XX0S001K
Issued date	2017/03/01
page	2/8

## 4. Features:

Series	Size	Power (W)	Resistance Value	Operation Temperature Range	TCR	Tolerance
RLS06	0603	0.50	5 ~ 20 mΩ	-55°C ~ +155°C	±50ppm/°C	±1% ±2% ±5%
RLS10	0805	0.75	5 ~ 30 mΩ			
RLS12	1206	1.0	5 ~ 40 mΩ			
RLS25	2512	2.0	5 ~ 10 mΩ			

## 5. Reliability Tests:

Test Items	Reference standard	Condition of Test	Test Limits
Temperature Coefficient of Resistance	IEC60115-1-4.8 JIS-C5201-4.8	+25°C ~ +125°C	Refer 4.0
Load Life	IEC60115-1-4.25.1 JIS-C5201-4.25.1	1000hours at rated power, 70°C, 1.5hours "ON", 0.5hour "OFF"	< ±1%
Short Time Overload	IEC60115-1-4.13 JIS-C5201-4.13	5 X rated power for 5s	< ±1%
Moisture no Load	IEC60115-1- 4.24.2.1a) JIS-C5201- 4.24.2.1a)	85°C, 85%RH, 1000hrs	< ±1%
Temperature cycle	IEC60115-1-4.19 JIS-C5201-4.19	-55°C & +155°C, 100cycle, 15min per extreme condition	< ±1%
Resistance to Soldering Heat	IEC60115-1-4.18 JIS-C5201-4.18	260±5°C for 10±1 sec	< ±0.5%
Solderability	IEC60115-1-4.17 JIS-C5201-4.17	245±5°C, 2±0.5sec	At least 95% of surface area of electrode shall be covered with new solder
High Temperature Exposure	IEC60115-1- 4.23.2 JIS-C5201-4.23.2	155°C, 1000hrs	< ±1%
Low Temperature Storage	IEC60115-1- 4.23.4 JIS-C5201-4.23.4	-55°C, 1000hrs	<±1%
Substrate Bending	IEC60115-1-4.33 JIS-C5201-4.33	Bending width 2mm	< ±0.5%
Insulation Resistance	IEC60115-1-4.6 JIS-C5201-4.6	100V DC for 1 minute	>100 MΩ



# Lead-Free Current Sensing Resistors RLS Series ( Halogen-Free )

Document No	TRLS-XX0S001K
Issued date	2017/03/01
page	3/8

## 5.1 Derating Curve

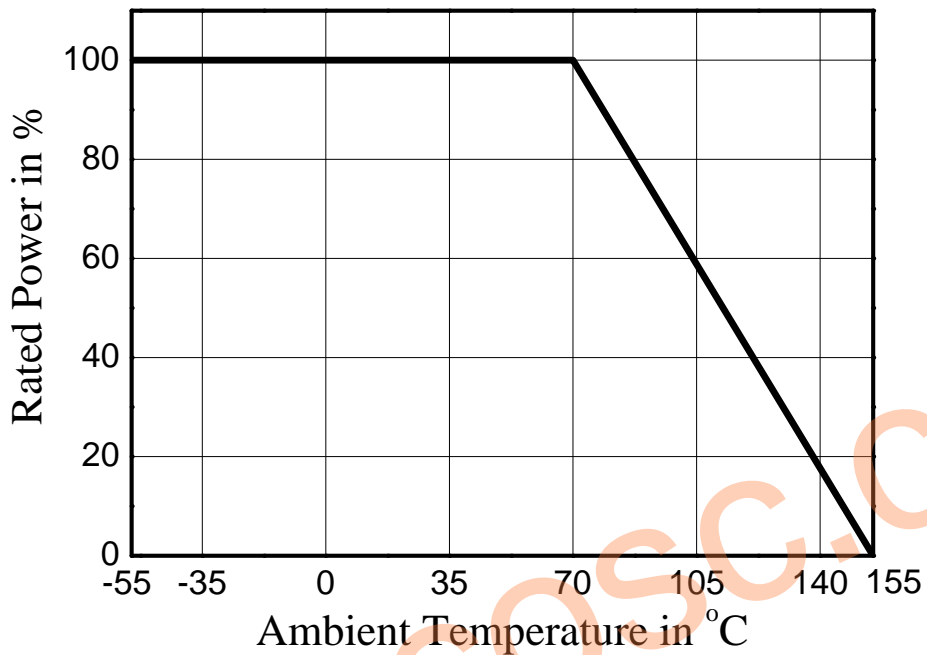

## 5.2 Rated Current & Voltage

The rated Current and Voltage are calculated by the following formula:

$$I = \sqrt{P \div R}$$

$$V = \sqrt{P \times R}$$

I: Rated Current (A)

V: Rated Voltage (V)

P: Rated Power (W)

R: Resistance Value ( $\Omega$ )



**Lead-Free Current Sensing Resistors**  
**RLS Series**  
**( Halogen-Free )**

Document No	TRLS-XX0S001K
Issued date	2017/03/01
page	4/8

**6. Recommended Solder Pad Dimension**

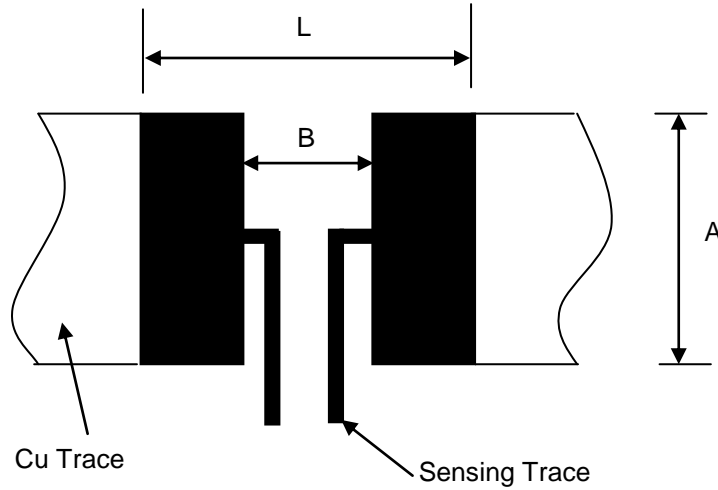

Unit: mm

Series	Resistance (mΩ)	A	L	B
RLS06	R = 5 R = 20	1.0	2.8	0.6
	5 < R < 20			0.85
RLS10	5 ≤ R < 10	1.4	3.2	0.8
	10 ≤ R ≤ 30			1.2
RLS12	5 ≤ R < 10	1.8	4.7	1.2
	10 ≤ R < 20			1.8
	20 ≤ R ≤ 40			2.2
RLS25	5 ≤ R ≤ 10	3.6	7.9	4.6

Note: \*The copper foil minimum thickness of PCB needs 3 oz



# Lead-Free Current Sensing Resistors RLS Series ( Halogen-Free )

Document No	TRLS-XX0S001K
Issued date	2017/03/01
page	5/8

## 7. Number of Package:

Series	RLS06	RLS10	RLS12	RLS25
Pieces/Package	5000	4000	4000	4000

## 8. Label:

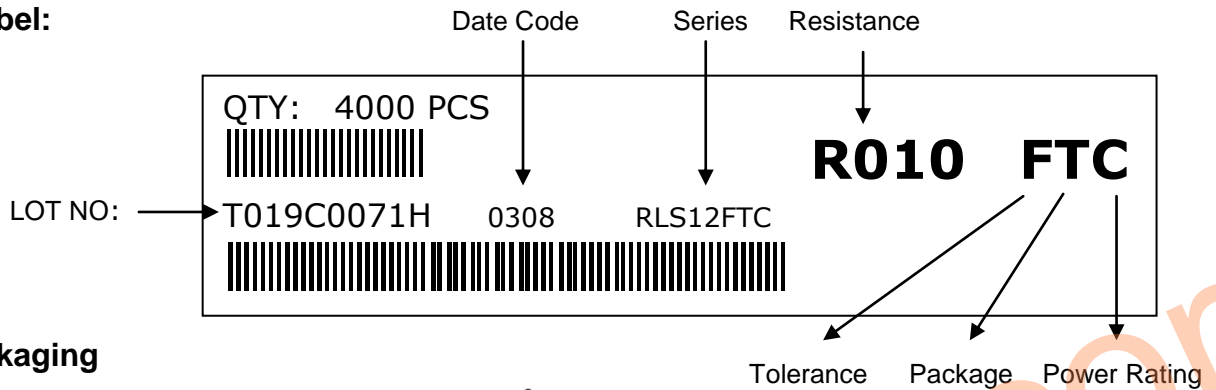

## 9. Packaging

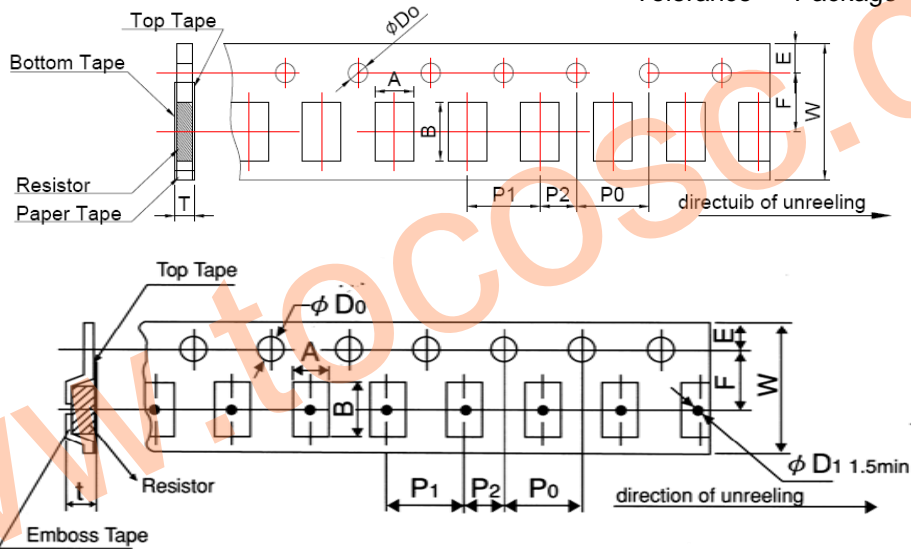

Tape packaging dimension

Packing	Type	A	B	W	F	E	P1	P2	P0	D0	T
Paper	RLS06	1.10	1.90	8.00	3.50	1.75	4.00	2.00	4.00	1.55	0.85
	RLS10	1.60	2.40	8.00	3.50	1.75	4.00	2.00	4.00	1.55	1.05
	RLS12	2.00	3.60	8.00	3.50	1.75	4.00	2.00	4.00	1.55	1.05
Embossed	RLS25	3.60	6.90	12.0	5.50	1.75	4.00	2.00	4.00	1.55	0.85
Tolerance		±0.15	±0.20	±0.20	±0.05	±0.10	±0.10	±0.10	±0.10	±0.10	±0.10



**Lead-Free Current Sensing Resistors**  
**RLS Series**  
**( Halogen-Free )**

Document No	TRLS-XX0S001K
Issued date	2017/03/01
page	6/8

**10. Reel Specification**

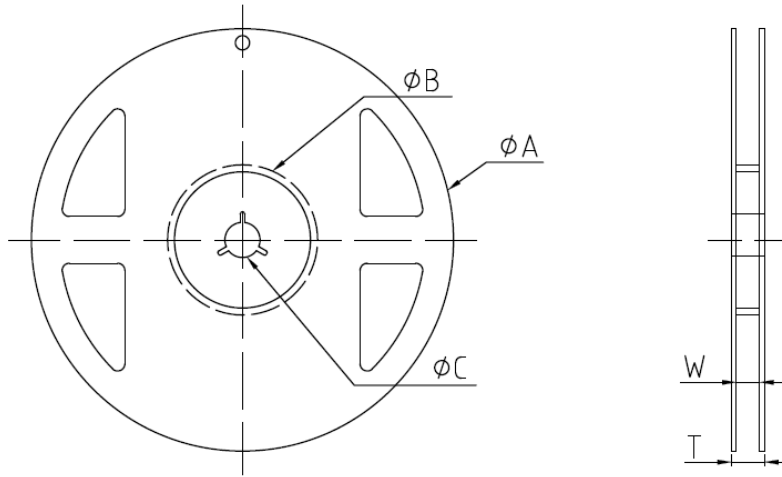

Series	$\phi A$	$\phi B$	$\phi C$	W	T
RLS06 RLS10 RLS12	180 $\pm$ 2.0	60 $\pm$ 1.0	13.0 $\pm$ 1.0	9.0 $\pm$ 1.0	11.4 $\pm$ 1.0
RLS25	180 $\pm$ 2.0	60 $\pm$ 1.0	13.0 $\pm$ 1.0	13.0 $\pm$ 1.0	15.4 $\pm$ 1.0

**11. Peeling Strength of Top Cover Tape**

Test Condition: 0.1 to 0.7 N at a peel-off speed of 300 mm / min.

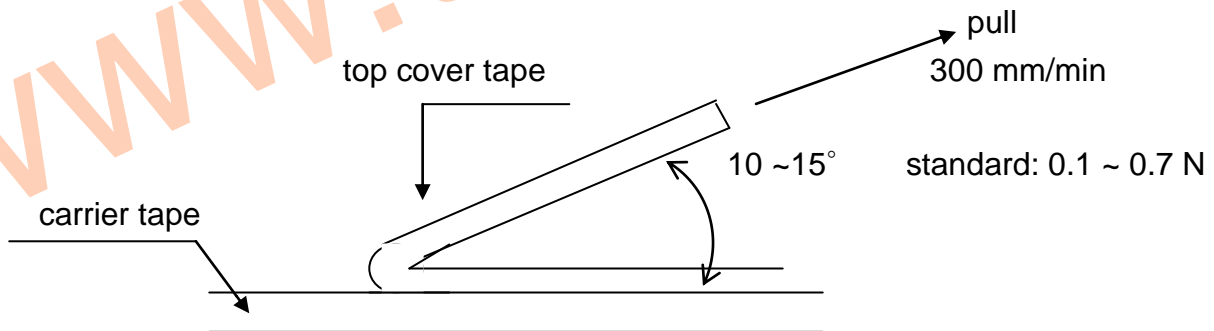

**12. Storage Conditions:**

Temperature: 5°C ~35°C, Humidity: 40%~75%

**13. Shelf Life:**

2 years from manufacturing date.



# Lead-Free Current Sensing Resistors RLS Series ( Halogen-Free )

Document No	TRLS-XX0S001K
Issued date	2017/03/01
page	7/8

## 14. Recommend IR – Reflow profile : (solder : Sn96.5 / Ag3 / Cu0.5)

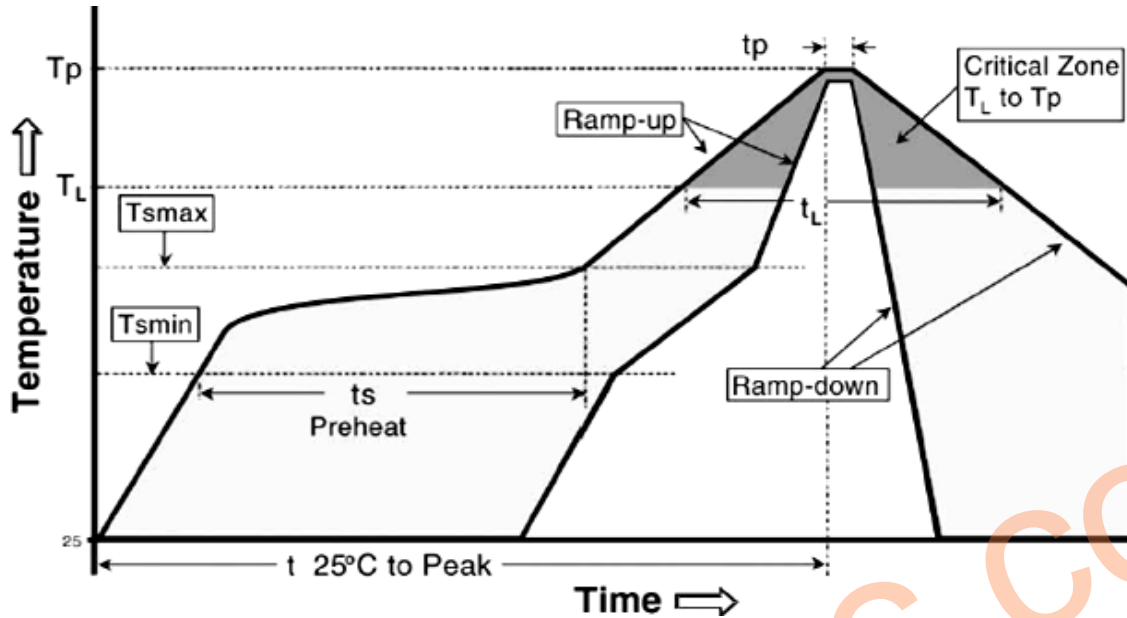

Alloyed Re-flow times : 3 times

Remark : To avoid discoloration phenomena of chip on terminal electrodes, please use N2 Re-flow furnace .

Iron Solder:  $350 \pm 10^{\circ}\text{C}$  ,  $3+1/-0$  sec, 1 time

Profile Feature	Lead (Pb )-Free Assembly
Average ramp-up rate ( $T_{smax}$ to $T_p$ )	$3^{\circ}\text{C} / \text{second max.}$
Preheat - Temperature Min ( $T_{smin}$ ) - Temperature Max ( $T_{smax}$ ) - Time ( $T_{smin}$ to $T_{smax}$ ) ( $t_s$ )	$150^{\circ}\text{C}$ $200^{\circ}\text{C}$ 60 -150 seconds
Time maintained above : - Temperature ( $T_L$ ) - Time ( $T_L$ )	$217^{\circ}\text{C}$ 60-120 seconds
Peak Temperature ( $T_p$ )	$260^{\circ}\text{C}$
Time within $+0^{\circ}\text{C}$ to $-5^{\circ}\text{C}$ of actual Peak Temperature ( $t_p$ ) <sup>2</sup>	10 seconds
Ramp-down Rate	$6^{\circ}\text{C}/\text{second max.}$
Time $25^{\circ}\text{C}$ to Peak Temperature	8mimutes max.



# Lead-Free Current Sensing Resistors RLS Series ( Halogen-Free )

Document No	TRLS-XX0S001K
Issued date	2017/03/01
page	8/8

## 15. Recommend Wave-Solder profile : (solder : Sn96.5 / Ag3 / Cu0.5)

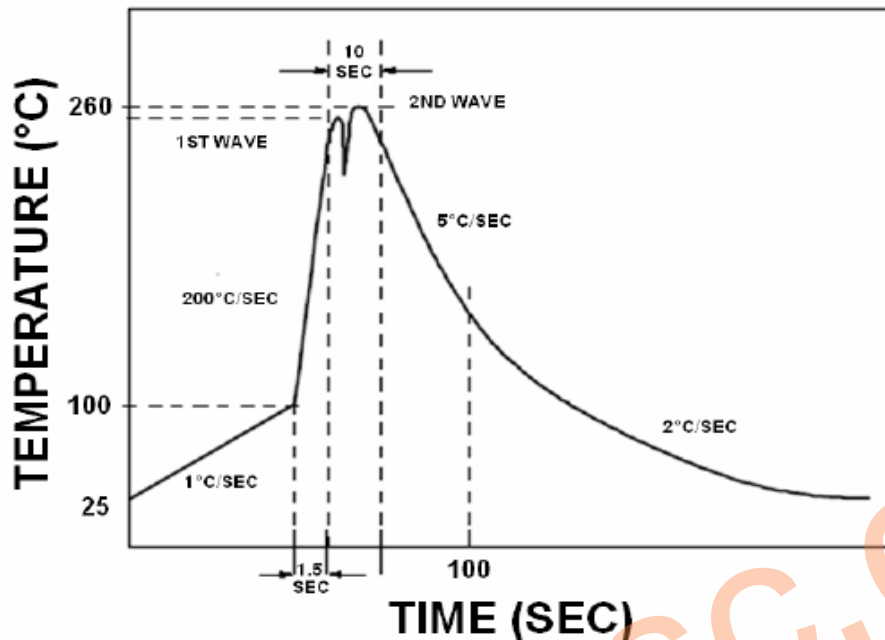

## 16. ECN

Engineering Change Notice: The customer will be informed with ECN if there is significant modification on the characteristics and materials described in Approval Sheet.

## 17. Manufacturing Country & City :

TA-I TECHNOLOGY CO., LTD. ( Taiwan– Tao Yuan )

Tel : (+886) 3-3246169 Fax : (+886) 3-3246167

### Associated companies :

(1)TA-I TECHNOLOGY ( SU ZHOU ) CO., LTD. ( China – Su Zhou)

Tel :(+86) 512-63457879 Fax : (+86) 512-63457869

(2) TA-I TECHNOLOGY ELECTRONIC (DONGGUAN) CO., LTD. ( China –Dongguan )

Tel : (+86) 769-8339-4790~3 Fax : (+86) 769-8339-4794

(3) FORTUNE TASK RESISTOR FACTORY ( China – Dongguan )

Tel : (+86) 769-8339-4790~3 Fax : (+86) 769-8339-4794

(4) TAI OHM ELECTRONICS ( M ) SDN. BHD. ( Malaysia – Penang )

Tel :(+60) 4- 3900480 Fax : (+60) 4-3901481

(5) P.T.TAI ELECTRONIC Indonesia ( Indonesia – Jakarta )

Tel :(+62) 21-44820254 Fax : (+62) 21-44820256