

## ■ 高精度厚膜片式固定電阻器

### HIGH PRECISION THICK FILM CHIP FIXED RESISTOR

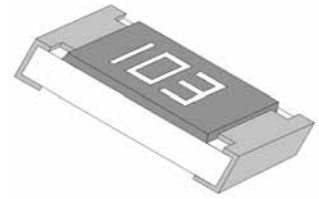

#### ● 特長 FEATURES

- \* 阻值誤差 ± 0.5%，溫度系數為 ± 50ppm/°C      High precision resistor with T.C.R. ± 50 ppm/°C and tolerance ± 0.5%.
- \* 體積小、重量輕。      Miniature and light weight.
- \* 適應再流焊與波峰焊。      Suit for reflow and wave flow solder.
- \* 電性能穩定，可靠性高。      Stable electrical capability, high reliability.
- \* 裝配成本低，並與自動裝貼設備匹配。      Low assembly cost, suit for automatic SMT equipment.
- \* 機械强度高、高頻特性優越。      Superior mechanical and frequency characteristics.
- \* 符合ROHS指令要求      RoHS compliant

#### ● 品名構成 TYPE DESIGNATION

例 Example

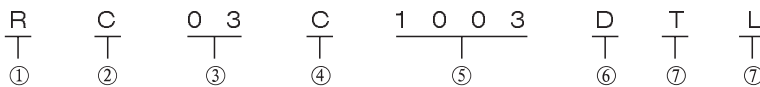

① 產品代號 Product Code
厚膜片式固定電阻器 Thick film chip fixed resistor

② 額定功率系列代號 Power Rating Series Code
C

③ 型號代號 Type Code	
代號 Code	型號 Type
02	0402
03	0603
05	0805
06	1206

④ 電阻溫度系數代號 Resistance Temperature Coefficient Code	
代號 Code	T.C.R
C	HTCR: ± 50ppm/°C

⑤ 電阻值代號 Resistance Value Code
<p>三位數(E-24系列): 前兩位表示有效數字, 第三位表示有效數字后零的個數 Three digits (E-24 series): The first two digits are significant figures and the third one denotes number of zeros.</p> <p>四位數(E-96系列): 前三位表示有效數字, 第四位表示有效數字后零的個數 Four digits (E-96 series): The first three digits are significant figures and the four one denotes number of zeros.</p> <p>小數點用 R 表示 Decimal point should be expressed by "R".</p> <p>例如 Example: 102=1KΩ ( E-24) 1002=10KΩ ( E-96)</p>

⑥ 電阻值誤差精度代號 Resistance Tolerance Code	
代號 Code	誤差精度 Tolerance
D	± 0.5%
F	± 1%

⑦ 包裝方式代號 Packing Style Code	
代號 Code	包裝方法 Packing Style
T	編帶包裝 Tape & Reel
B	塑料盒包裝 Bulk Case
C	塑料袋散裝 Case

⑧ 無鉛化等級代號 Lead-free Level Code	
代號 Code	無鉛化等級 Lead-free Level
無表示 No Marking	端子無鉛(端子鉛含量 ≤ 100ppm) Terminal Lead-free (pb content in terminal ≤ 100ppm)
L	整體低鉛 (< 1000ppm) Low Lead ( pb content in resistor body < 1000ppm)
G	整體無鉛 (< 100ppm) Low Lead ( pb content in resistor body < 100ppm)

\* 產品標記表示方法請與廠家聯系

• 結構及規格尺寸 CONSTRUCTION AND DIMENSION

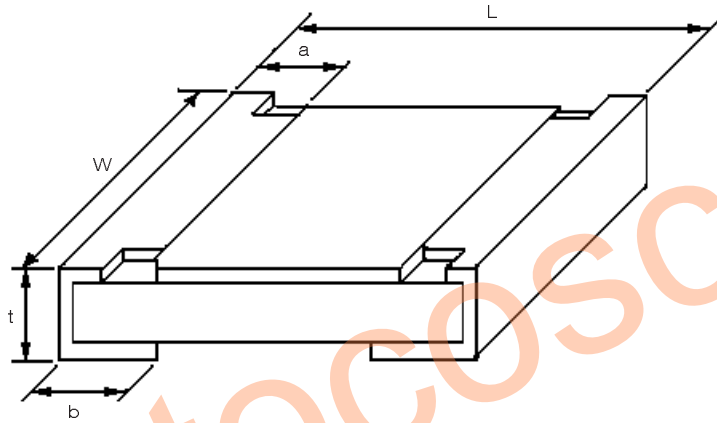
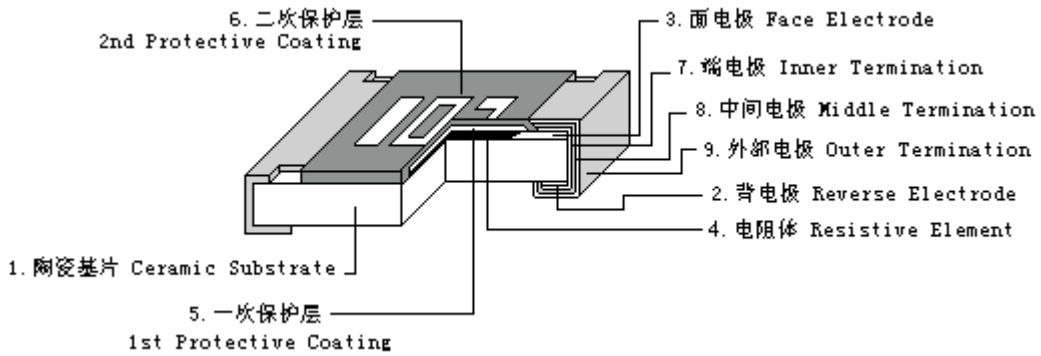

單位unit:mm

型號 TYPE	L	W	t	a	b
0402	1.00±0.10	0.50±0.10	0.30±0.10	0.20±0.10	0.25±0.10
0603	1.60±0.15	0.80±0.15	0.40±0.10	0.30±0.20	0.30±0.20
0805	2.00±0.20	1.25±0.15	0.50±0.10	0.30±0.20	0.40±0.20
1206	3.20±0.20	1.60±0.15	0.55±0.10	0.50±0.20	0.50±0.20

• 產品外觀 APPEARANCE

\* 電阻器表面保護膜覆蓋完好且難以脫落,表面平整。

The surface of resistor is covered with Protective Coating which hard to fade, and the surface of coating should avoid unevenness.

\* 電阻器引出端電極覆蓋均勻,鍍層較難脫落,且平整、無裂痕、針孔、變色。

The terminal part is covered equable, the plating is hard to fade, and should avoid unevenness, flaw, pinhole and discoloration.

\* 電阻器芯片無裂痕、標志可辨。

With a clear mark, the resistor body is crack-free.

● 參考標準 REFERENCE STANDARD

GB/T 5729-2003

GB/T 9546-1995

● 負荷下降曲線 DERATING CURVE

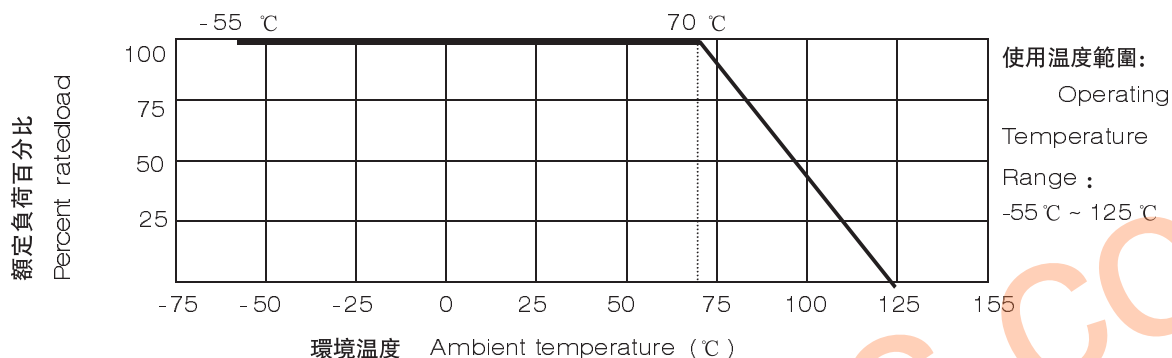

\* 當電阻使用的環境溫度超過70°C時，其額定負荷(額定功率或額定電流)按上述曲線下降。

For resistors operated in ambient over 70°C, rated load (power rating or current rating) shall be derated in accordance with the above figure.

● 額定值 RATINGS

項目 Item	0402	0603	0805	1206
額定功率 Power Rating	1/16W	1/16W	1/10W	1/8W
最大工作電壓 Max. Working Voltage	50V	50V	100V	200V
最大過負荷電壓 Max. Overload Voltage	100V	100V	200V	400V
阻值範圍 Resistance Range	100Ω~100KΩ E-24、E-96系列			
電阻溫度係數 Resistance Temperature Coefficient	HTCR:±50ppm/°C			
阻值誤差精度 Resistance Tolerance	±0.5%、±1%			
使用溫度範圍 Operating Temperature Range	-55°C~+125°C			
額定溫度 Rated Temperature	+70°C			

注：額定電壓=√額定功率×標稱電阻值 或最大工作電壓兩者中的較小值。

Note: Rated Voltage=√Power Rating×Resistance Value or Max. Working Voltage, whichever is lower.

● 特性 CHARACTERISTICS

項目 Item	標準 Specifications	測試方法( GB/T 5729-2003) Test Methods (GB/T 5729-2003)
端頭強度 Bending Strength	無可見損傷No mechanical damage $\Delta R \leq \pm ( 1.0\%R+0.05\Omega )$	彎曲距離(Bending Distance): 0402、0603、0805、1206: 3mm; 保持時間(duration):10S ± 1S
溫度循環 Temperature Cycling	無可見損傷No mechanical damage $\Delta R \leq \pm ( 1.0\%R+0.05\Omega )$	-55℃ ( 30分鐘) ~常溫( 2分鐘~3分鐘) ~125℃ ( 30分鐘) 5個循環 -55℃ ( 30min) ~normal temperature( 2min~3min) ~125℃ ( 30min) 5 cycles
短時間過負載 Short Time Overload	無可見損傷No mechanical damage $\Delta R \leq \pm ( 2.0\%R+0.05\Omega )$	2.5倍額定電壓或最大過負荷電壓( 取最小者) 保持5秒 2.5 × Rated voltage or Max. Overload Voltage whichever is lower for 5 seconds
耐焊接熱 Resistance to Soldering Heat	無可見損傷No mechanical damage $\Delta R \leq \pm ( 1.0\%R+0.05\Omega )$	270℃ ± 5℃ 10 ± 1秒 270℃ ± 5℃ 10s ± 1s
穩態濕熱 Steady state humidity	無可見損傷No mechanical damage $\Delta R \leq \pm ( 3.0\%R+0.1\Omega )$	40℃ ± 2℃ 90%~95%RH 1000小時 40℃ ± 2℃ 90%~95%RH 1000h
70℃ 耐久性 Load Life	無可見損傷No mechanical damage $\Delta R \leq \pm ( 3.0\%R+0.1\Omega )$	70℃ ± 2℃,1000小時,額定電壓通1.5小時/斷0.5小時 70℃ ± 2℃,1000h,Rated voltage 1.5h on/0.5h off
上限類別溫度耐久性 Endurance at upper temperature	無可見損傷No mechanical damage $\Delta R \leq \pm ( 3.0\%R+0.1\Omega )$	125℃ ± 2℃ 1000小時 125℃ ± 2℃ 1000h
耐溶劑性 Resistance to Solvent	無可見損傷No mechanical damage $\Delta R \leq \pm ( 1.0\%R+0.05\Omega )$	浸入三氯乙烯 10h ± 1h Dip in chloroethylene for 10h ± 1h.
可焊性 Solderability	可焊面積 ≥ 95% 95% Cover Min	240℃ ± 5℃ 2s ± 0.5s 240℃ ± 5℃ 2s ± 0.5s
附着力 Adhesion	外觀無可見損傷 No mechanical damage	施加力5N 10s ± 1s Applying 5N 10s ± 1s

● 包裝 PACKAGING

\* 編帶包裝 Tape and reel

紙帶編帶 Paper taping

0402

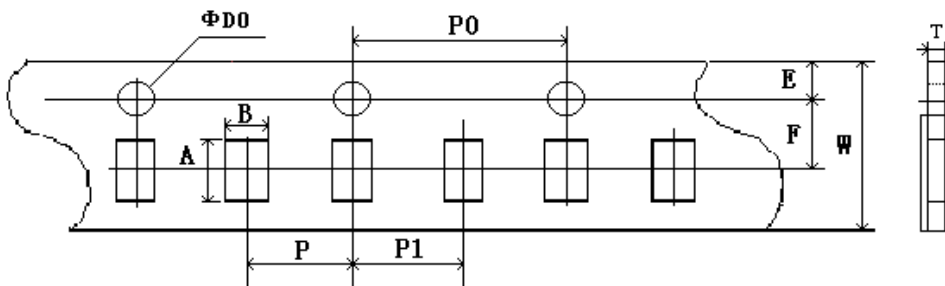

0603、0805、1206:

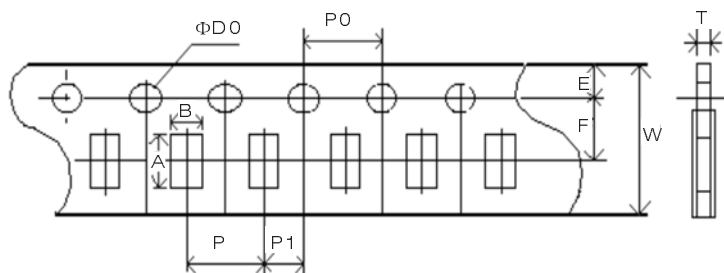

型號 TYPE	A	B	W	F	E
0402	$1.20 \pm 0.1$	$0.70 \pm 0.1$	$8.0 \pm 0.20$	$3.5 \pm 0.05$	$1.75 \pm 0.1$
0603	$1.85 \pm 0.1$	$1.10 \pm 0.1$	$8.0 \pm 0.20$	$3.5 \pm 0.05$	$1.75 \pm 0.1$
0805	$2.35 \pm 0.1$	$1.65 \pm 0.1$	$8.0 \pm 0.20$	$3.5 \pm 0.05$	$1.75 \pm 0.1$
1206	$3.50 \pm 0.2$	$1.90 \pm 0.2$	$8.0 \pm 0.20$	$3.5 \pm 0.05$	$1.75 \pm 0.1$

型號 TYPE	P	P0	P1	$\Phi D0$	T
0402	$2.0 \pm 0.05$	$4.0 \pm 0.1$	$2.0 \pm 0.05$	$1.5 \pm 0.1$	$0.42 \pm 0.05$
0603	$4.0 \pm 0.1$	$4.0 \pm 0.1$	$2.0 \pm 0.05$	$1.5 \pm 0.1$	$0.60 \pm 0.1$
0805	$4.0 \pm 0.1$	$4.0 \pm 0.1$	$2.0 \pm 0.05$	$1.5 \pm 0.1$	$0.75 \pm 0.1$
1206	$4.0 \pm 0.1$	$4.0 \pm 0.1$	$2.0 \pm 0.05$	$1.5 \pm 0.1$	$0.75 \pm 0.1$

卷盤 Reel

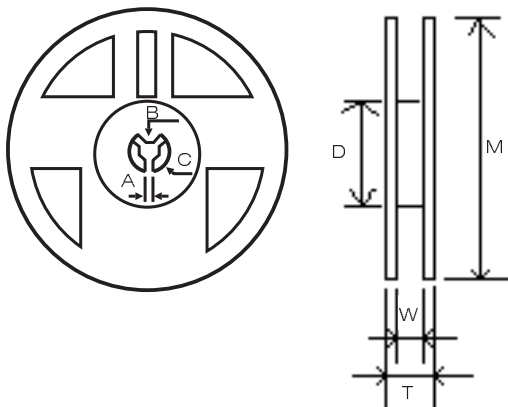

## 高精度厚膜片式固定電阻器

## HIGH PRECISION THICK FILM CHIP FIXED RESISTOR

型號 TYPE	M	W	T	A	B	C	D
0402							
0603	178	9.5	12.5	2.0	13.0	21.0	58.0
0805	±2.0	±1.0	±1.5	±0.5	±0.5	±0.5	±2.0
1206							

\* 塑料盒包裝Bulk case

單位unit:mm

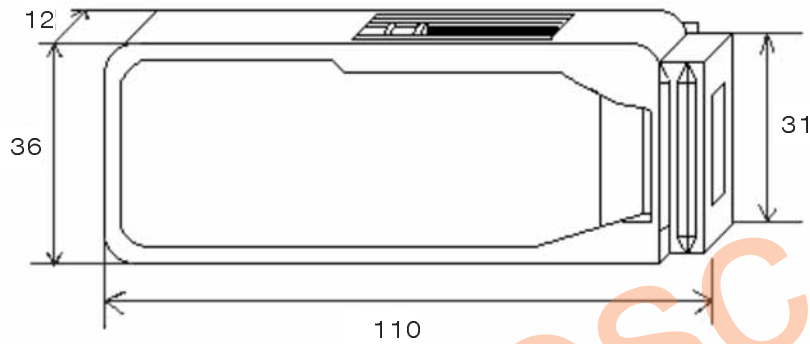

### • 包裝數量 PACKAGING QUANTITY

包裝方法 Packaging style	編帶 Tape and reel		塑料盒 Bulk case				塑料袋散裝 Bulk	
	型號 Type	數量 (PCS) Quantity	型號 Type	數量 (PCS) Quantity	型號 Type	數量 (PCS) Quantity	型號 Type	數量 (PCS) Quantity
	0402	10000	0402	50000	0603	25000	0402	≤50000
	0603 0805 1206	5000	0603 0805 1206	5000	0805	10000	0603 0805 1206	≤10000