

片状多层陶瓷电容器

www.tocosc.com

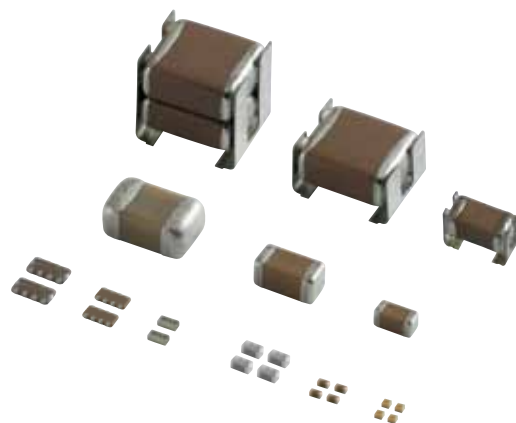

本目录中的符号说明

超小型 尺寸(长 x 宽): 尺寸小于等于 0.6 x 0.3 mm 的产品

高 Q 高频低功耗
通过制定陶瓷材料和电机材料, 可在 VHF、UHF 和微波或以外的频带实现低功耗。

低 ESL 型 低电感
本电容器的设计使得电容器高频侧的寄生电感元件 (ESL) 变得更小。

抗噪 产品适用于于啸叫降低和低失真
本产品通过采用合适的材料和配置, 可抑制使用陶瓷电容器时发生的啸叫。

裂纹偏转 产品可耐受弯曲裂纹
该电容器设计用来尽可能地防止电路板出现弯曲时因裂纹引起的故障模式所致的故障。

焊接断裂 产品可抑制焊接裂纹的形成
本电容器配有与贴片相连的金属端子和引线。金属端子和引线减轻了焊接时膨胀和收缩形成的应力, 从而抑制焊接裂纹的形成。

降额 电压和温度降额推荐产品
当连续施加在某个工作电路中的电容器的电压低于电容器的额定电压 (降低额定值) 时, 本产品适用。
此模型确保了在最高工作温度下, 额定电压 x100% 时耐久试验中的试验条件。在下图推荐的低额定值电压和温度条件下使用本产品可确保具有与普通产品一样的可靠性保证等级。

降额工作电压和温度时建议采用的条件

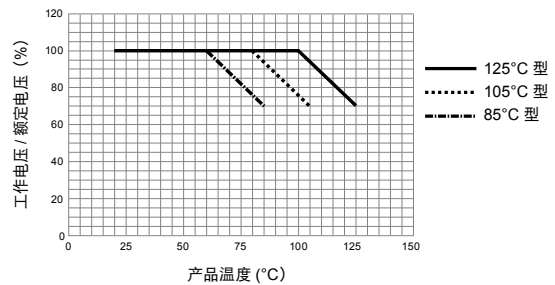

欧盟 RoHS 指令

- 本产品目录中的所有产品均符合欧盟 RoHS 指令。
- 欧盟 RoHS 指令是指欧盟规定的“关于在电子电气设备中限制使用某些有害物质的指令 2011/65/EU”。
- 详情请参见本公司网站“Murata's Approach for EU RoHS” (<http://www.murata.com/info/rohs.html>)。

目录

截止至2014年8月的产品规格。

品名表示法	p2	
选择指南	p5	
静电容量表	p6	
电容器表		
一般用 GRM 系列	p17	分卷
高频型高Q型1005 (单位: mm) / 0402 (单位: 英寸) 最大尺寸 GJM 系列	p87	p7
结合用上&下电极型 GMA系列	p109	p8
结合/金锡焊接用产品GMD 系列	p111	p9
高频型高Q型1608 (单位: mm) / 0603 (单位: 英寸) 最小尺寸 GQM 系列	p114	p10
树脂外部电极型 GRJ系列	p123	p11
高效静电容量&高容许纹波电流GR3系列	p125	p12
一般用金属端子型KRM系列	p127	p13
金属端子型高效&耐高纹波电流KR3系列	p130	p14
8-端子低 ESL 型 LLA 系列	p133	p14
长宽逆转低 ESL 型LLL 系列	p135	p15
10-端子低 ESL 型 LLM 系列	p137	p15
ESR 控制低 ESL 型 LLR 系列	p139	p15
△警告/注意事项	p141	
认证标准	p163	
网站介绍 SimSurfing	p165	
产品信息	p166	

请参见村田主页 (<http://www.murata.com/>)。
 一旦您不能在目录上找到品名。

● 品名表示法

一般用片状多层陶瓷电容器

(品名)

GR	M	18	8	B1	1H	102	K	A01	D
①	②	③	④	⑤	⑥	⑦	⑧	⑨	⑩

① 型号 ② 系列

型号	代号	系列
GJ	M	高频型 HiQ型 1005 (单位: mm) / 0402 (单位: 英寸) 最大尺寸
GM	A	结合用上&下电极型
	D	结合/金锡焊接用产品
GQ	M	高频型 HiQ型 1608 (单位: mm) / 0603 (单位: 英寸) 最小尺寸
GR	3	高效静容量 & 高容许纹波电流
	J	树脂外部电极型
	M	一般用产品
KR	3	金属端子型/高效静容量 & 高容许纹波电流
	M	金属端子型
LL	A	8-端子低 ESL 型
	L	长宽逆转低ESL 型
	M	10 端子低 ESL 型
	R	ESR控制低ESL 型

④ 高度尺寸 (T) (KR□系列除外)

代号	尺寸 (T)
2	0.2mm
3	0.3mm
4	0.4mm
5	0.5mm
6	0.6mm
7	0.7mm
8	0.8mm
9	0.85mm
A	1.0mm
B	1.25mm
C	1.6mm
D	2.0mm
E	2.5mm
M	1.15mm
Q	1.5mm
S	2.8mm
X	按照个别尺寸规格规定。

⑤ 电容尺寸 (长x宽)

代号	电容尺寸 (长x宽)	尺寸代号(单位: 英寸)
02	0.4×0.2mm	01005
03	0.6×0.3mm	0201
05	0.5×0.5mm	0202
08	0.8×0.8mm	0303
0D	0.38×0.38mm	015015
15	1.0×0.5mm	0402
18	1.6×0.8mm	0603
1U	0.6×1.0mm	02404
21	2.0×1.25mm	0805
22	2.8×2.8mm	1111
31	3.2×1.6mm	1206
32	3.2×2.5mm	1210
42	4.5×2.0mm	1808
43	4.5×3.2mm	1812
55	5.7×5.0mm	2220

④ 高度尺寸 (T) (仅限KR□系列)

代号	尺寸 (T)
E	1.8mm
F	1.9mm
K	2.7mm
L	2.8mm
Q	3.7mm
T	4.8mm
W	6.4mm

接下页。 

(品名)

GR	M	18	8	B1	1H	102	K	A01	D
①	②	③	④	⑤	⑥	⑦	⑧	⑨	⑩

接上页。

⑤ 温度特性

温度特性代号			温度特性			工作温度范围	个别温度下的静电容量变化 (%)					
代号	共用STD代号		参考温度	温度范围	静电容量变化或温度系数		-55°C		*3		-10°C	
							最大值	最小值	最大值	最小值	最大值	最小值
1X	SL	JIS	20°C	20 to 85°C	+350 to -1000ppm/°C	-55 to 125°C	-	-	-	-	-	-
2C	CH	JIS	20°C	20 to 125°C	0±60ppm/°C	-55 to 125°C	0.82	-0.45	0.49	-0.27	0.33	-0.18
3C	CJ	JIS	20°C	20 to 125°C	0±120ppm/°C	-55 to 125°C	1.37	-0.9	0.82	-0.54	0.55	-0.36
3U	UJ	JIS	20°C	20 to 85°C	-750±120ppm/°C	-25 to 85°C	-	-	4.94	2.84	3.29	1.89
4C	CK	JIS	20°C	20 to 125°C	0±250ppm/°C	-55 to 125°C	2.56	-1.88	1.54	-1.13	1.02	-0.75
5C	C0G	EIA	25°C	25 to 125°C	0±30ppm/°C	-55 to 125°C	0.58	-0.24	0.4	-0.17	0.25	-0.11
7U	U2J	EIA	25°C	25 to 125°C *2	-750±120ppm/°C	-55 to 125°C	8.78	5.04	6.04	3.47	3.84	2.21
B1	B *1	JIS	20°C	-25 to 85°C	±10%	-25 to 85°C	-	-	-	-	-	-
B3	B	JIS	20°C	-25 to 85°C	±10%	-25 to 85°C	-	-	-	-	-	-
C7	X7S	EIA	25°C	-55 to 125°C	±22%	-55 to 125°C	-	-	-	-	-	-
C8	X6S	EIA	25°C	-55 to 105°C	±22%	-55 to 105°C	-	-	-	-	-	-
D7	X7T	EIA	25°C	-55 to 125°C	+22%, -33%	-55 to 125°C	-	-	-	-	-	-
D8	X6T	EIA	25°C	-55 to 105°C	+22%, -33%	-55 to 105°C	-	-	-	-	-	-
E7	X7U	EIA	25°C	-55 to 125°C	+22%, -56%	-55 to 125°C	-	-	-	-	-	-
R1	R *1	JIS	20°C	-55 to 125°C	±15%	-55 to 125°C	-	-	-	-	-	-
R6	X5R	EIA	25°C	-55 to 85°C	±15%	-55 to 85°C	-	-	-	-	-	-
R7	X7R	EIA	25°C	-55 to 125°C	±15%	-55 to 125°C	-	-	-	-	-	-

*1 施加额定电压的50%时有保证。

*2 额定电压最高100Vdc: 25 到 85°C

*3 -25°C (参考温度: 20°C) / -30°C (参考温度: 25°C)

⑥ 额定电压

代号	额定电压
0E	DC2.5V
0G	DC4V
0J	DC6.3V
1A	DC10V
1C	DC16V
1E	DC25V
1H	DC50V
1J	DC63V
1K	DC80V
2A	DC100V
2D	DC200V
2E	DC250V
2W	DC450V
2H	DC500V
2J	DC630V
3A	DC1kV
3D	DC2kV
3F	DC3.15kV
YA	DC35V

⑦ 静电容量

由3位字母数字表示。单位为皮法(pF)。第1位和第2位数字为有效数字，第3位数字表示有效数字后的0的个数。有小数点时以大写字母"R"表示。此时，所有数字均为有效数字。
 如果包含有任何不是"R"的字母，则表明该特指的品名是一个非标准的部件。

例如)

代号	静电容量
R50	0.50pF
1R0	1.0pF
100	10pF
103	10000pF

⑧ 静电容量公差

代号	静电容量公差
B	±0.1pF
C	±0.25pF
D	±0.5pF (10pF 及以下) ±0.5% (10pF 及以上)
F	±1%
G	±2%
J	±5%
K	±10%
M	±20%
W	±0.05pF

接下页。

(品名)

GR	M	18	8	B1	1H	102	K	A01	D
1	2	3	4	5	6	7	8	9	10

接上页。

⑨个别规格代号（不包括 LLR）
由3位数字表示。

⑨ESR（仅限 LLR 系列）

代号	ESR
E01	100mΩ
E03	220mΩ
E05	470mΩ
E07	1000mΩ

⑩包装方法

代号	包装方法
L	ø180mm 压纹带
D/E/W	ø180mm 纸带
K	ø330mm 压纹带
J/F	ø330mm 纸带
B	散装袋
T	浅盘

如果您查找的品名未在本表中列出，请联系我们。

www.tocosc.com

一旦您不能在目录上找到品名，请参见村田主页（<http://www.murata.com/index.html>）。

片状多层陶瓷电容器选择指南

系列	超小型 (小于 0201)	低损耗/HiQ	低 ESL 型	自动防故障	耐弯曲破裂	抗焊接破裂	抗噪、低失真	结合用	特殊用途	安全规格认证品
一般用	GRM <small>页码 p17</small>									
	GA2									
	GA3									
	GJM <small>页码 p87</small>									
	GJ4									
	GJ8									
	GMA <small>页码 p109</small>									
	GMD <small>页码 p111</small>									
	GQM <small>页码 p114</small>									
	GRJ <small>页码 p123</small>									
	GR3 <small>页码 p125</small>									
	GR4									
	GR7									
	KRM <small>页码 p127</small>									
	KR3 <small>页码 p130</small>									
	LLA <small>页码 p133</small>									
	LLL <small>页码 p135</small>									
	LLM <small>页码 p137</small>									
LLR <small>页码 p139</small>										
ZRA										
ZRB										
汽车用 (Cat. No. C03)	GCM									
	GCD									
	GCE									
	GCG									
	GCJ									
	GC3									
	KCM									
	KC3									

静电容量表

如何阅览静电容量表

L×W (mm)	0.4×0.2		0.6×0.3		1.0
最大T (mm)	0.22		0.33		0.4
额定电压(Vdc)	25		25		50
静电容量/温度特性代号	C0G	CΔ	C0G	CΔ	C0G
0.10pF					p101
0.20pF	p88	p91	p94	p97	p101
1.0pF	p88	p91	p94	p98	p101
2.0pF	p88	p91	p95	p98	p101
3.0pF	p88	p91	p95	p98	p102

值可按尺寸、额定电压和温度特性降序排列。

请参阅品名列表所在的页面。
检查品名列表中的适用产品编号。

温度特性表

表格按温度特性代码标有颜色。
各代码的含义请参阅下表。

EIA:	C0G	U2J	X7R	X7S	X7T	X7U	X6S	X6T	X5R
JIS:	CK	CJ	CH	SL	UJ	R	B		

温度特性代号		温度特性			工作温度范围	个别温度下的静电容量变化 (%)					
		参考温度	温度范围	静电容量变化或温度系数		-55°C		*2		-10°C	
代号						最大值	最小值	最大值	最小值	最大值	最小值
C0G	EIA	25°C	25 到 125°C	0±30ppm/°C	-55 到 125°C	0.58	-0.24	0.4	-0.17	0.25	-0.11
CK	JIS	20°C	20 到 125°C	0±250ppm/°C	-55 到 125°C	2.56	-1.88	1.54	-1.13	1.02	-0.75
CJ	JIS	20°C	20 到 125°C	0±120ppm/°C	-55 到 125°C	1.37	-0.9	0.82	-0.54	0.55	-0.36
CH	JIS	20°C	20 到 125°C	0±60ppm/°C	-55 到 125°C	0.82	-0.45	0.49	-0.27	0.33	-0.18
SL	JIS	20°C	20 到 85°C	+350 到 -1000ppm/°C	-55 到 125°C	-	-	-	-	-	-
U2J	EIA	25°C	25 到 125°C *1	-750±120ppm/°C	-55 到 125°C	8.78	5.04	6.04	3.47	3.84	2.21
UJ	JIS	20°C	20 到 85°C	-750±120ppm/°C	-25 到 85°C	-	-	4.94	2.84	3.29	1.89
X7R	EIA	25°C	-55 到 125°C	±15%	-55 到 125°C	-	-	-	-	-	-
X7S	EIA	25°C	-55 到 125°C	±22%	-55 到 125°C	-	-	-	-	-	-
X7T	EIA	25°C	-55 到 125°C	+22%, -33%	-55 到 125°C	-	-	-	-	-	-
X7U	EIA	25°C	-55 到 125°C	+22%, -56%	-55 到 125°C	-	-	-	-	-	-
R	JIS	20°C	-55 到 125°C	±15%	-55 到 125°C	-	-	-	-	-	-
X6S	EIA	25°C	-55 到 105°C	±22%	-55 到 105°C	-	-	-	-	-	-
X6T	EIA	25°C	-55 到 105°C	+22%, -33%	-55 到 105°C	-	-	-	-	-	-
X5R	EIA	25°C	-55 到 85°C	±15%	-55 到 85°C	-	-	-	-	-	-
B	JIS	20°C	-25 到 85°C	±10%	-25 到 85°C	-	-	-	-	-	-

*1 额定电压最高100Vdc: 25 到 85°C

*2 -25°C (参考温度: 20°C) / -30°C (参考温度: 25°C)

静电容量表

p00 品名列表中的每个数字指的是印在页面底部的页码。

(→ ■ GRM 系列温度补偿型)

L×W (mm)	3.2×2.5												4.5×2.0		4.5×3.2						5.7×5.0							
	1.25				1.5				2.0				1.0		1.5			2.0			1.5			2.0				
最大T (mm)	2000	1000	630	500	1000	630	500	250	1000	630	500	250	3150	1000	630	500	1000	630	500	1000	630	500	1000	630	500	1000	630	500
额定电压(Vdc)	U2J	U2J	U2J	U2J	U2J	U2J	U2J	U2J	U2J	U2J	U2J	U2J	COG	U2J	U2J	U2J	U2J	U2J	U2J	U2J	U2J	U2J	U2J	U2J	U2J	U2J	U2J	U2J
静电容量/温度特性代号																												
0.10pF																												
0.20pF																												
0.50pF																												
1.0pF																												
2.0pF																												
3.0pF																												
4.0pF																												
5.0pF																												
6.0pF																												
7.0pF																												
8.0pF																												
9.0pF																												
10pF																												
10.5pF																												
11pF																												
12pF																												
12.5pF																												
13pF																												
14pF																												
15pF																												
16pF																												
17pF																												
18pF																												
19pF																												
20pF																												
21pF																												
22pF																												
24pF																												
27pF																												
30pF																												
33pF																												
36pF																												
39pF																												
43pF																												
47pF																												
51pF																												
56pF																												
62pF																												
68pF																												
75pF																												
82pF																												
91pF																												
94pF																												
96pF																												
100pF																												
120pF																												
150pF																												
180pF																												
220pF																												
270pF																												
330pF																												
390pF																												
470pF																												
560pF																												
680pF																												
820pF																												
1000pF																												
1200pF																												
1500pF																												
1800pF																												
2200pF																												
2700pF																												
3300pF																												
3900pF																												
4700pF																												
5600pF																												
6800pF																												
8200pF																												
10000pF																												
12000pF																												
15000pF																												
18000pF																												
22000pF																												
27000pF																												
33000pF																												
39000pF																												
47000pF																												
56000pF																												
68000pF																												
82000pF																												
0.10μF																												
0.12μF																												

静电容量表

p00 品名列表中的每个数字指的是印在页面底部的页码。

GRM 系列高介电常数型

p00 ← 品名列表 JIS: R B EIA: X7R X7S X7T X7U X6S X6T X5R

L×W (mm)	0.4×0.2						0.6×0.3										1.0×0.5													
	0.22						0.33										0.22													
最大T (mm)	0.22						0.33										0.22													
额定电压(Vdc)	16	10	6.3	4	2.5	50	35	25		16		10		6.3		4	10	6.3	4											
静电容量/温度特性代号	X7R	X7R	X5R, B	X5R, B	X6T	X5R	X6T	X7R	B	X5R	X7R, R	X6S	X5R, B	X7D, R	X6S	X5R, B	X7D, R	X5R, B	X7R, R	X6S	X5R, B	X6S	X5R, B	X6S	X5R, B	X6S	X5R, B	X7T		
100pF	p74	p74	p74	p74				p75	p75		p75																			
150pF	p74	p74	p74	p74				p75	p75		p75																			
220pF	p74	p74	p74	p74				p75	p75		p75																			
330pF	p74	p74	p74	p74				p75	p75		p75																			
470pF	p74	p74	p74	p74				p75	p75		p75																			
680pF		p74	p74	p74				p75	p75		p75																			
820pF		p74																												
1000pF	p74	p74	p74	p74	p74			p75	p75		p75	p75			p75															
1500pF			p74	p74	p74			p75	p75		p75	p75			p75															
2200pF			p74	p74	p74						p75				p75	p75			p76											
3300pF			p74	p74	p74						p75				p75	p75			p76											
4700pF			p74	p74	p74						p75				p75	p75			p76	p76	p76	p76			p76					
6800pF			p74	p74	p74						p75				p75	p75			p76	p76	p76	p76			p76					
10000pF			p74	p74	p74						p75				p75	p75			p76	p76	p76	p76								
15000pF				p74			p74								p75	p76			p76	p76			p76	p76						
22000pF				p74			p74								p75	p76			p76	p76			p76	p76						
33000pF				p74			p75								p75	p76			p76	p76			p76	p76						
47000pF				p74			p75								p76	p76			p76	p76			p76	p76						
68000pF				p74			p75								p76	p76			p76	p76			p76	p76						
0.10μF			p74	p74	p75	p75				p75		p75	p75	p75	p75	p76	p76	p76	p76	p76			p76			p76	p77	p77	p77	p77
0.15μF																														
0.22μF																														
0.33μF																														
0.47μF																														
0.68μF																														
1.0μF																														
2.2μF																														
4.7μF																														
10μF																														
22μF																														
47μF																														
100μF																														
220μF																														



静电容量表

p00 品名列表中的每个数字指的是印在页面底部的页码。

(→ ■ GRM 系列高介电常数型)

p00 ← 品名列表 JIS: R B EIA: X7R X7S X7T X7U X6S X6T X5R

L×W (mm)	1.0×0.5																											
	0.22			0.3				0.33				0.55																
	最大T (mm)		4	2.5	50	25	16	10	10	6.3	4	100	50		35		25		16									
静电容量/温度特性代号	X6D	X5R	X7T	X7R, R	B	X7R	B	X7R	B	X5R	X5R, B	X6T	X5R, B	X6T	X7R	X7R, R	X6S	X5R, B	X6S	X5R	X7R, R	X6S	X5R, B	X7R, R	X6S	X5R, B		
100pF																												
150pF																												
220pF				p77	p77	p77									p77	p77	p78											
330pF				p77	p77	p77									p77	p77	p78											
470pF				p77	p77	p77									p77	p77	p78											
680pF				p77	p77	p77									p77	p77	p78											
820pF																												
1000pF				p77	p77	p77									p77	p77	p78											
1500pF				p77	p77	p77									p77	p77	p78											
2200pF						p77	p77								p77	p77	p78											
3300pF								p77	p77						p77	p77	p78											
4700pF										p77	p77				p77	p77	p78											
6800pF												p77	p77															
10000pF														p77														
15000pF															p77													
22000pF															p77													
33000pF															p77													
47000pF															p77													
68000pF															p77													
0.10μF	p77			p77											p77													
0.15μF																												
0.22μF	p77			p77																								
0.33μF																												
0.47μF	p77																											
0.68μF																												
1.0μF	p77	p77													p77	p77	p77	p77										
2.2μF																												
4.7μF																												
10μF																												
22μF																												
47μF																												
100μF																												
220μF																												



静电容量表

p00 品名列表中的每个数字指的是印在页面底部的页码。

(→ ■ GRM 系列高介电常数型)

p00 ← 品名列表 JIS: **R** **B** EIA: **X7R** **X7S** **X7T** **X7U** **X6S** **X6T** **X5R**

L×W (mm)	1.0×0.5																1.6×0.8										
	0.55						0.6						0.65	0.7				0.5									
最大T (mm)	10			6.3			4	35	25	16	6.3	4	2.5	6.3	25	16	10	6.3	4	2.5	25	16	6.3	4			
静电容量/温度特性代号	X7R	X6S	X5R, B	X7R	X6S	X5R, B	X7R	X5R	X6S	X6S	X5R, B	X5R, B	X6T	X6S	X5R	X6S	X5R	X7S	X6S	X7S	X5R	X5R	X5R, B	X5R, B	X5R	X5R	
100pF																											
150pF																											
220pF																											
330pF																											
470pF																											
680pF																											
820pF																											
1000pF																											
1500pF																											
2200pF																											
3300pF																											
4700pF																											
6800pF																											
10000pF																											
15000pF																											
22000pF																											
33000pF																											
47000pF																											
68000pF																											
0.10μF																											
0.15μF			p79	p79			p79	p79																			
0.22μF	p79		p79	p79			p79	p79																			
0.33μF			p79	p79			p79	p79																			
0.47μF	p79		p79	p79			p79	p79																			
0.68μF			p79	p79			p79	p79																			
1.0μF		p79		p79			p79	p79	p79	p79													p80	p80	p80	p80	
2.2μF			p79		p79	p79								p79	p79	p79	p79	p79	p79								
4.7μF													p79	p79													
10μF																						p79	p79			p80	p80
22μF																											
47μF																											
100μF																											
220μF																											



静电容量表

p00 品名列表中的每个数字指的是印在页面底部的页码。

(→ ■ GRM 系列高介电常数型)

p00 ← 品名列表 JIS: R B EIA: X7R X7S X7T X7U X6S X6T X5R

L×W (mm)	1.6×0.8																											
最大T (mm)	0.55					0.9						0.95				1.0												
额定电压(Vdc)	16	10	6.3	250	200	100	50	25	16	10	6.3	25	16	10	50	35												
静电容量/温度特性代号	X5R	X6S	X5R	X7T	X6S	X7R	X7R	X7R	X7R, R	X5R, B	X7R, R	X5R, B	X7D, R	X6S	X5R, B	X7D	X5R, B	B	X5R	X6S	X5R, B	X7S	X5R, B	X5R	X6S	X5R		
100pF																												
150pF																												
220pF						p80	p80	p80	p80	p80	p80																	
330pF						p80	p80	p80	p80	p80	p80																	
470pF						p80	p80	p80	p80	p80	p80																	
680pF						p80	p80	p80	p80	p80	p80																	
820pF																												
1000pF						p80	p80	p80	p80	p80	p80																	
1500pF						p80	p80	p80	p80	p80	p80																	
2200pF						p80	p80	p80	p80	p80	p80																	
3300pF								p80	p80	p80	p80																	
4700pF								p80	p80	p80	p81																	
6800pF								p80	p80	p80	p81																	
10000pF								p80	p80	p80	p81							p81										
15000pF								p80	p80	p80	p81							p81										
22000pF								p80	p80	p80	p81							p81										
33000pF								p80	p80	p80	p81	p81	p81					p81										
47000pF								p80	p80	p80	p81	p81	p81					p81										
68000pF								p80	p80	p80	p81	p81	p81					p81										
0.10μF						p80	p80	p80	p81									p81										
0.15μF								p80	p81	p81	p81	p81	p81					p81										
0.22μF								p80	p80	p81	p81	p81	p81					p81										
0.33μF																		p81	p81	p81	p81							
0.47μF																		p81	p81	p81								
0.68μF																		p81	p81	p81								
1.0μF																		p81	p81	p81								
2.2μF																		p81	p81	p81	p81							
4.7μF	p80	p80	p80	p80	p80													p81	p81	p82	p82	p82						
10μF																		p81										
22μF																												
47μF																												
100μF																												
220μF																												



静电容量表

p00 品名列表中的每个数字指的是印在页面底部的页码。

(→ ■ GRM 系列高介电常数型)

p00 ← 品名列表 JIS: R B EIA: X7R X7S X7T X7U X6S X6T X5R

L×W (mm)	1.6×0.8											2.0×1.25														
	1.0											0.7	0.95													
	25			16			10	6.3	4		16	100	50	35		25			16			10		6.3		
最大T (mm)	X7S	X6S	X5R	X7S	X6S	X7T	X7T	X5R, B	X6S	X5R, B	X6S	X7R	X7R, R	X5R, B	X6S	X5R	X7R, R	X6S	X5R, B	X7R, R	X6S	X5R, B	X7D	X5R, B	X6S	X5R, B
静电容量/温度特性代号	X7S	X6S	X5R	X7S	X6S	X7T	X7T	X5R, B	X6S	X5R, B	X6S	X7R	X7R, R	X5R, B	X6S	X5R	X7R, R	X6S	X5R, B	X7R, R	X6S	X5R, B	X7D	X5R, B	X6S	X5R, B
100pF																										
150pF																										
220pF																										
330pF																										
470pF																										
680pF																										
820pF																										
1000pF																										
1500pF																										
2200pF																										
3300pF																										
4700pF																										
6800pF																										
10000pF																										
15000pF																										
22000pF																										
33000pF																										
47000pF																										
68000pF																										
0.10μF																										
0.15μF																										
0.22μF																										
0.33μF																										
0.47μF																										
0.68μF																										
1.0μF																										
2.2μF																										
4.7μF																										
10μF																										
22μF																										
47μF																										
100μF																										
220μF																										



www.tocosc.com

静电容量表

p00 品名列表中的每个数字指的是印在页面底部的页码。

(→ ■ GRM 系列高介电常数型)

p00 ← 品名列表

JIS: R B

EIA: X7R X7S X7T X7U X6S X6T X5R

L×W (mm)	2.0×1.25																										
	0.95			1.0						1.35						1.4											
最大T (mm)	0.95			1.0						1.35						1.4											
额定电压(Vdc)	4			250						100						16											
静电容量/温度特性代号	X6S	X5R	X6T	X7R	X7R	X7R	X7R	X6S	X7S	X6S	X7S	X5R	X7R	X7R, R	X5R, B	R	X6S	X5R, B	X7R	X5R, B	X7R	X5R, B	X7R, R	X5R, B	X7R	X6S	
100pF																											
150pF																											
220pF																											
330pF																											
470pF																											
680pF																											
820pF																											
1000pF																											
1500pF																											
2200pF																											
3300pF																											
4700pF																											
6800pF																											
10000pF																											
15000pF																											
22000pF																											
33000pF																											
47000pF																											
68000pF																											
0.10μF																											
0.15μF																											
0.22μF																											
0.33μF																											
0.47μF																											
0.68μF																											
1.0μF																											
2.2μF																											
4.7μF																											
10μF																											
22μF																											
47μF																											
100μF																											
220μF																											



静电容量表

p00 品名列表中的每个数字指的是印在页面底部的页码。

(→ ■ GRM 系列高介电常数型)

p00 ← 品名列表 JIS: R B EIA: X7R X7S X7T X7U X6S X6T X5R

L×W (mm)	2.0×1.25																										
最大T (mm)	1.4													1.45													
额定电压(Vdc)	10		6.3		4		250	200	50		35			25			16			10		6.3		4			
静电容量/温度特性代号	X7R	B	X7R	X6S	X7U	X6S	X7R	X7R	X7S	X6S	X7S	X6S	X5R	X7S	X6S	X5R	X7S	X6S	X5R	X7T	X6S	X5R	X7T	X5R, B	X6S	X5R, B	
100pF																											
150pF																											
220pF																											
330pF																											
470pF																											
680pF																											
820pF																											
1000pF																											
1500pF																											
2200pF																											
3300pF																											
4700pF																											
6800pF																											
10000pF																											
15000pF																											
22000pF																											
33000pF																											
47000pF																											
68000pF																											
0.10μF																											
0.15μF																											
0.22μF																											
0.33μF																											
0.47μF																											
0.68μF																											
1.0μF																											
2.2μF																											
4.7μF	p83																										
10μF	p83		p83																								
22μF		p83		p83	p83	p83																					
47μF																											
100μF																											
220μF																											

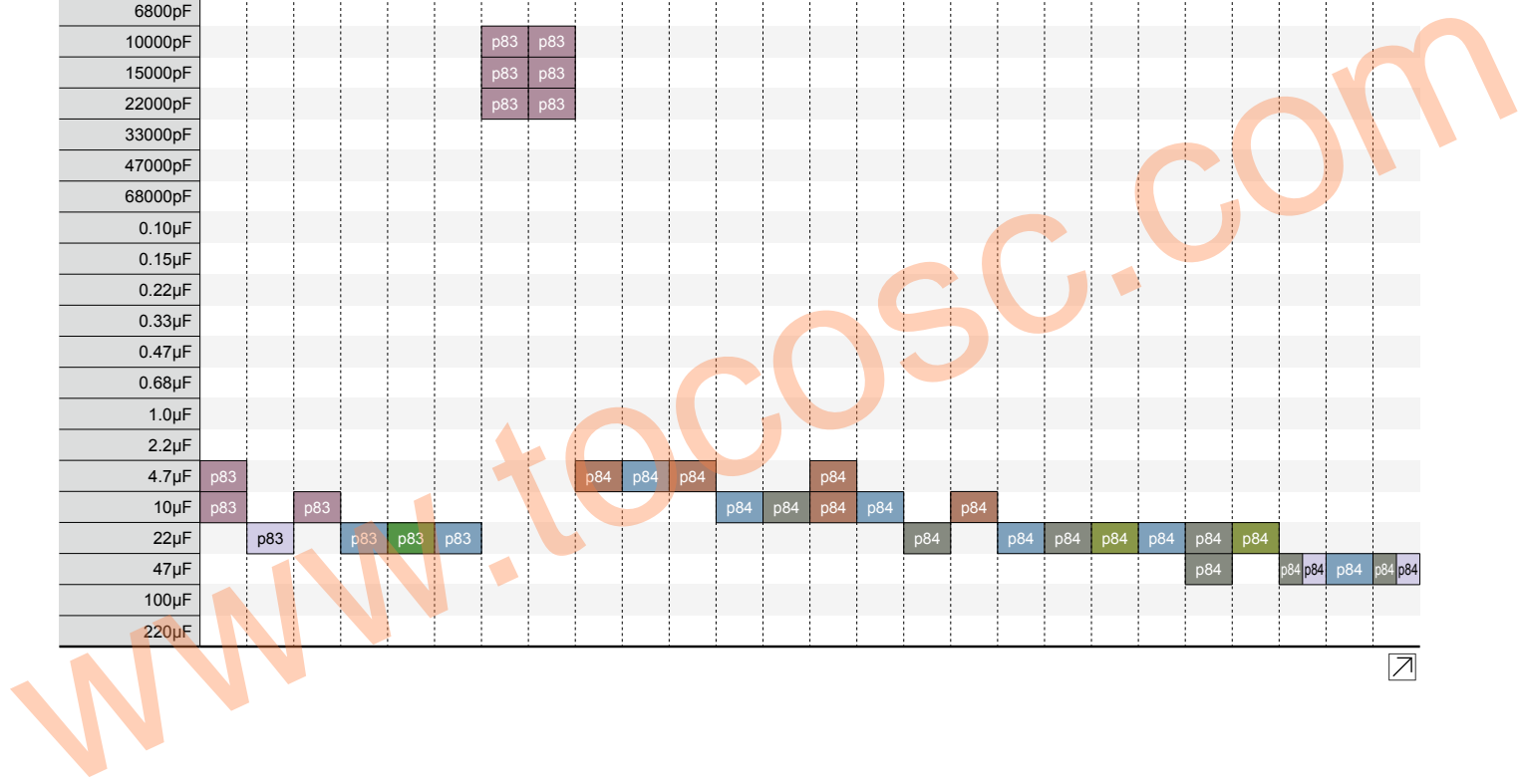

静电容量表

p00 品名列表中的每个数字指的是印在页面底部的页码。

(→ ■ GRM 系列高介电常数型)

p00 ← 品名列表 JIS: R B EIA: X7R X7S X7T X7U X6S X6T X5R

L×W (mm)	3.2×1.6																							
	0.95					1.0		1.25					1.3		1.8									
最大T (mm)	35	25	16	10	6.3	630	1000	630	250	200	50	25	100	1000	630	250	200	100	50	25	16			
额定电压(Vdc)	35	25	16	10	6.3	630	1000	630	250	200	50	25	100	1000	630	250	200	100	50	25	16			
静电容量/温度特性代号	X5R	R	X5R, B	X5R, B	X6S	X5R, B	X7R	X7R	X7R	X7R	X7R	B	X5R	X7R	X7R	X7R	X7R	X7R	X7R	X5R, B	X7R	X5R, B	X7R	X6S
100pF																								
150pF																								
220pF																								
330pF																								
470pF										p84														
680pF										p84														
820pF																								
1000pF										p84	p84													
1500pF										p84	p84													
2200pF										p84	p84													
3300pF										p84	p84													
4700pF										p84	p84													
6800pF										p84		p84												
10000pF										p84														
15000pF																								
22000pF																								
33000pF																								
47000pF																								
68000pF																								
0.10μF																								
0.15μF																								
0.22μF																								
0.33μF																								
0.47μF																								
0.68μF																								
1.0μF																								
2.2μF																								
4.7μF																								
10μF																								
22μF																								
47μF																								
100μF																								
220μF																								



静电容量表

p00 品名列表中的每个数字指的是印在页面底部的页码。

(→ ■ GRM 系列高介电常数型)

p00 ← 品名列表 JIS: R B EIA: X7R X7S X7T X7U X6S X6T X5R

L×W (mm)	3.2×1.6														3.2×2.5									
	1.8						1.9								1.5				1.8		2.0		2.2	
最大T (mm)	16	10	6.3		4		100	25	16	6.3		4		1000	630	250	200	100	1000	630	250	200	25	
静电容量/温度特性代号	X5R, B	X7R	X5R, B	X7D	X6S	X5R, B	X7U	X6S	X7R	X6S	X7S	X6T	X5R	X7U	X6T	X5R	X7R	X7R	X7R	X7R	X7R	X7R	X7R	X7R
100pF																								
150pF																								
220pF																								
330pF																								
470pF																								
680pF																								
820pF																								
1000pF																								
1500pF																								
2200pF																								
3300pF																								
4700pF																								
6800pF																								
10000pF																								
15000pF																								
22000pF																								
33000pF																								
47000pF																								
68000pF																								
0.10μF																								
0.15μF																								
0.22μF																								
0.33μF																								
0.47μF																								
0.68μF																								
1.0μF																								
2.2μF																								
4.7μF																								
10μF																								
22μF																								
47μF																								
100μF																								
220μF																								

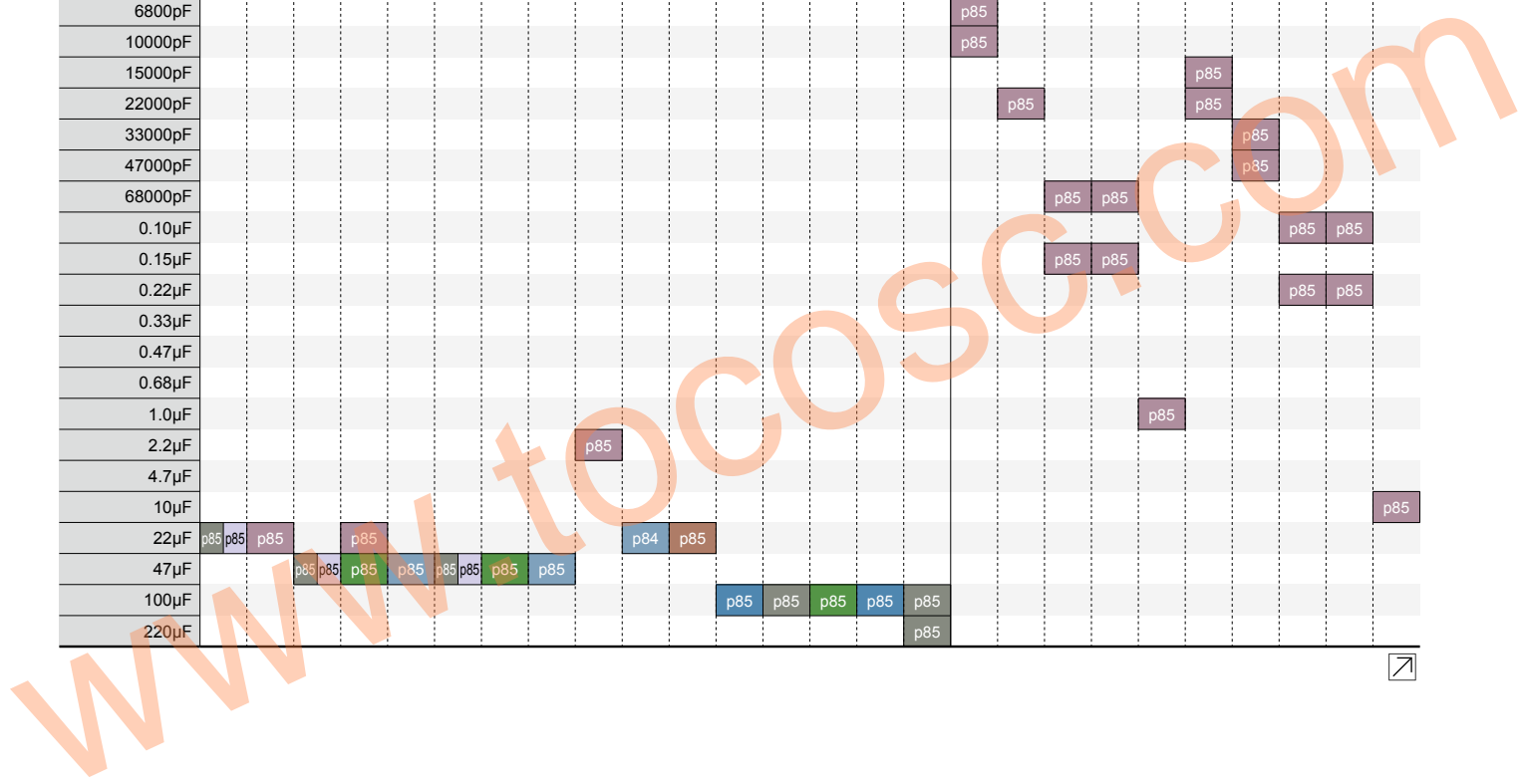

静电容量表

p00 品名列表中的每个数字指的是印在页面底部的页码。

(→ ■ GRM 系列高介电常数型)

p00 ← 品名列表 JIS: R B EIA: X7R X7S X7T X7U X6S X6T X5R

L×W (mm)	3.2×2.5											4.5×3.2						5.7×5.0									
最大T (mm)	2.7											1.5			2.0			2.0									
额定电压(Vdc)	100	80	63	50		35		25		16		10		6.3		4		630	250	200	1000	630	250	200	1000	630	
静电容量/温度特性代号	X7R	X7R	X7R	X7R	X5R, B	X7R	X5R, B	X7R	X5R, B	X7R	X6S	X5R, B	X7R	X5R, B	X7D	X5R, B	X7U	X7R	X7R	X7R	X7R	X7R	X7R	X7R	X7R	X7R	
100pF																											
150pF																											
220pF																											
330pF																											
470pF																											
680pF																											
820pF																											
1000pF																											
1500pF																											
2200pF																											
3300pF																											
4700pF																											
6800pF																											
10000pF																											
15000pF																											
22000pF																											
33000pF																											
47000pF																											
68000pF																											
0.10μF																											
0.15μF																											
0.22μF																											
0.33μF																											
0.47μF																											
0.68μF																											
1.0μF																											
2.2μF	p85																										
4.7μF		p85																									
10μF			p85	p85	p85	p85	p85	p85	p85																		
22μF								p85	p85	p85																	
47μF											p85	p85	p85	p85													
100μF												p85	p85	p85	p85	p85											
220μF																											



静电容量表

p00 品名列表中的每个数字指的是印在页面底部的页码。

(→ ■ GRM 系列高介电常数型)

p00 ← 品名列表 JIS: R B EIA: X7R X7S X7T X7U X6S X6T X5R

L×W (mm)	5.7×5.0	
最大T (mm)	2.0	
额定电压(Vdc)	250	200
静电容量/温度特性代号	X7R	X7R
100pF		
150pF		
220pF		
330pF		
470pF		
680pF		
820pF		
1000pF		
1500pF		
2200pF		
3300pF		
4700pF		
6800pF		
10000pF		
15000pF		
22000pF		
33000pF		
47000pF		
68000pF		
0.10μF		
0.15μF		
0.22μF		
0.33μF	p85	p86
0.47μF	p86	p86
0.68μF	p86	p86
1.0μF	p86	p86
2.2μF		
4.7μF		
10μF		
22μF		
47μF		
100μF		
220μF		



静电容量表

■ GRM 系列



一般用GRM系列的静电容量表，请参看插入的“一般用GRM系列片状多层陶瓷电容器”静电容量表。

■ GJM系列温度补偿类型

p00 ← 品名列表	JIS: CK CJ CH		EIA: C0G			
L×W (mm)	0.4×0.2		0.6×0.3		1.0×0.5	
最大T (mm)	0.22		0.33		0.55	
额定电压(Vdc)	25		25		50	
静电容量/温度特性代号	C0G	CΔ	C0G	CΔ	C0G	CΔ
0.10pF					p101	p104
0.20pF	p88	p91	p94	p97	p101	p104
1.0pF	p88	p91	p94	p98	p101	p105
2.0pF	p88	p91	p95	p98	p101	p105
3.0pF	p88	p91	p95	p98	p102	p105
4.0pF	p89	p92	p95	p98	p102	p105
5.0pF	p89	p92	p95	p99	p102	p106
6.0pF	p89	p92	p96	p99	p102	p106
7.0pF	p90	p93	p96	p99	p103	p106
8.0pF	p90	p93	p96	p100	p103	p107
9.0pF	p90	p94	p97	p100	p104	p107
10pF	p91	p94	p97	p101	p104	p107
11pF	p91	p94	p97	p101	p104	p107
12pF	p91	p94	p97	p101	p104	p108
13pF	p91	p94	p97	p101	p104	p108
15pF	p91	p94	p97	p101	p104	p108
16pF	p91	p94	p97	p101	p104	p108
18pF	p91	p94	p97	p101	p104	p108
20pF	p91	p94	p97	p101	p104	p108
22pF	p91	p94	p97	p101	p104	p108
24pF			p97	p101	p104	p108
27pF			p97	p101	p104	p108
30pF			p97	p101	p104	p108
33pF			p97	p101	p104	p108
36pF					p104	p108
39pF					p104	p108
43pF					p104	p108
47pF					p104	p108

10pF以下，不标明每0.1pF的信息。
 详情请参见品名列表。

静电容量表

■ GMA 系列高介电常数型

p00 ← 品名列表 JIS: **R** **B** EIA: **X7R** **X5R**

L×W (mm)	0.38×0.38			0.5×0.5						0.8×0.8									
最大T (mm)	0.35			0.4						0.6									
额定电压(Vdc)	10			100	25		10			6.3		100	25		10			6.3	
静电容量/温度特性代号	X7R	R	B	X7R	X7R	B	X7R	R	B	X5R	B	X7R	X7R	B	X7R	R	B	X5R	B
100pF				p110															
150pF				p110															
220pF				p110															
330pF				p110															
470pF				p110															
680pF				p110															
1000pF	p110	p110	p110	p110															
1500pF	p110	p110	p110		p110	p110						p110							
1800pF	p110	p110	p110																
2200pF					p110	p110						p110							
3300pF					p110	p110						p110							
4700pF					p110	p110						p110							
6800pF							p110	p110	p110			p110							
10000pF	p110	p110					p110	p110	p110				p110	p110					
15000pF							p110	p110	p110				p110	p110					
22000pF							p110	p110	p110				p110	p110					
33000pF															p110	p110	p110		
47000pF															p110	p110	p110		
68000pF															p110	p110	p110		
0.10μF										p110	p110				p110	p110	p110		
0.47μF																		p110	p110

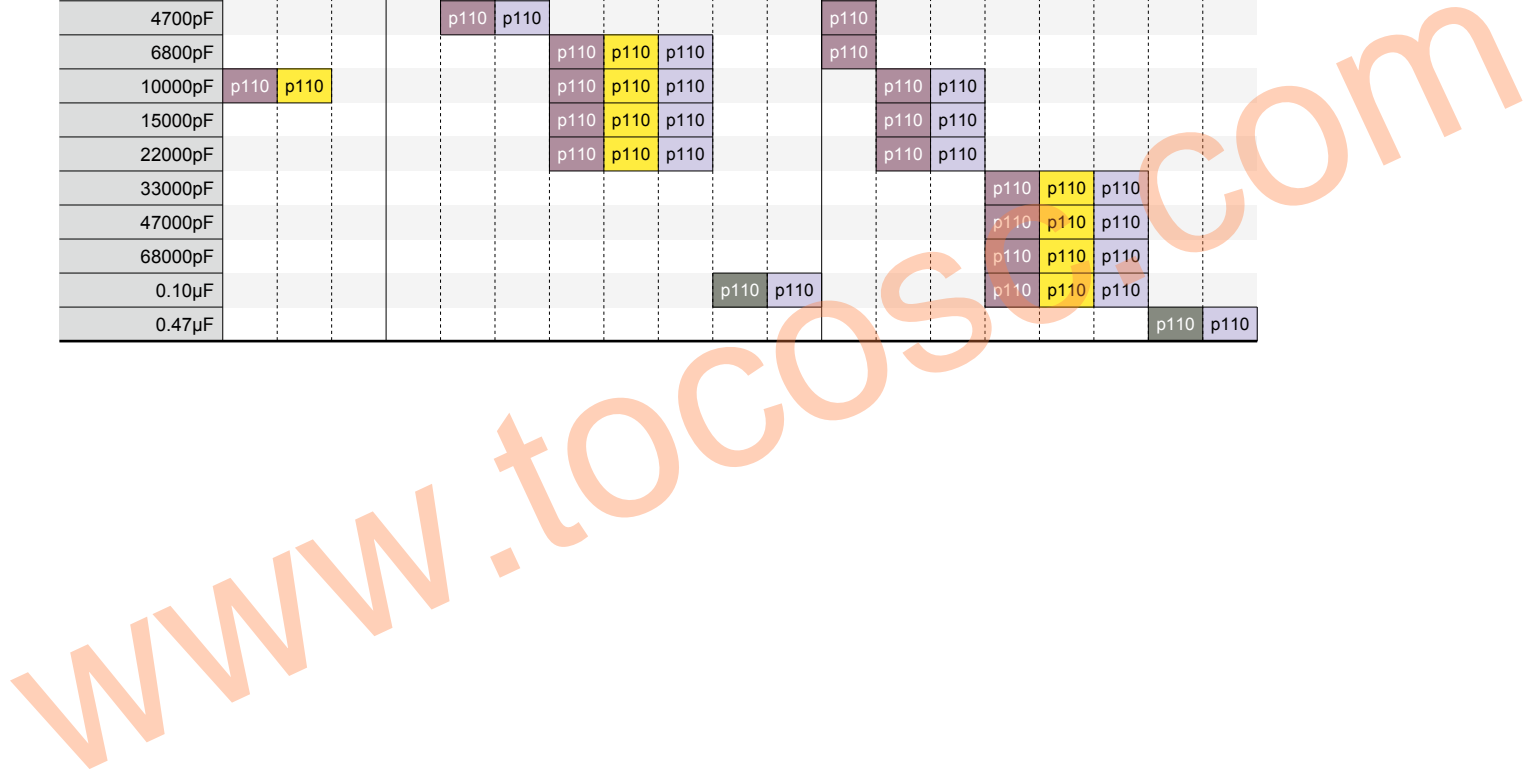

静电容量表

■ GMD 系列高介电常数型

p00 ← 品名列表 JIS: R B EIA: X7R X5R

L×W (mm)	0.6×0.3										1.0×0.5											
	0.33										0.55											
最大T (mm)	25			16			10			6.3		50			25			16			10	
额定电压(Vdc)	X7R	R	B	X7R	R	B	X7R	R	B	X5R	B	X7R	R	B	X7R	R	B	X7R	R	B	X5R	B
静电容量/温度特性代号	X7R	R	B	X7R	R	B	X7R	R	B	X5R	B	X7R	R	B	X7R	R	B	X7R	R	B	X5R	B
100pF	p112	p112	p112																			
120pF	p112	p112	p112																			
150pF	p112	p112	p112																			
180pF	p112	p112	p112																			
220pF	p112	p112	p112									p112	p112	p113								
270pF	p112	p112	p112									p112	p113	p113								
330pF	p112	p112	p112									p112	p113	p113								
390pF	p112	p112	p112									p112	p113	p113								
470pF	p112	p112	p112									p112	p113	p113								
560pF	p112	p112	p112									p112	p113	p113								
680pF	p112	p112	p112									p112	p113	p113								
820pF	p112	p112	p112									p112	p113	p113								
1000pF	p112	p112	p112									p112	p113	p113								
1200pF	p112	p112	p112									p112	p113	p113								
1500pF	p112	p112	p112									p112	p113	p113								
1800pF				p112	p112	p112						p112	p113	p113								
2200pF				p112	p112	p112						p112	p113	p113								
2700pF				p112	p112	p112						p112	p113	p113								
3300pF				p112	p112	p112						p112	p113	p113								
3900pF							p112	p112	p112			p112	p113	p113								
4700pF							p112	p112	p112			p112	p113	p113								
5600pF							p112	p112	p112						p113	p113	p113					
6800pF							p112	p112	p112						p113	p113	p113					
8200pF							p112	p112	p112						p113	p113	p113					
10000pF							p112	p112	p112						p113	p113	p113					
12000pF															p113	p113	p113					
15000pF															p113	p113	p113					
18000pF															p113	p113	p113					
22000pF															p113	p113	p113					
27000pF															p113	p113	p113					
33000pF															p113	p113	p113					
39000pF															p113	p113	p113					
47000pF															p113	p113	p113					
56000pF										p112	p112							p113	p113	p113		
68000pF										p112	p112							p113	p113	p113		
82000pF										p112	p112							p113	p113	p113		
0.10μF										p112	p112							p113	p113	p113		
0.12μF																					p113	p113
0.15μF																					p113	p113
0.18μF																					p113	p113
0.22μF																					p113	p113
0.27μF																					p113	p113
0.33μF																					p113	p113
0.39μF																					p113	p113
0.47μF																					p113	p113

静电容量表

■ GQM 系列温度补偿型

p00 ← 品名列表 JIS: **CK** **CJ** **CH** EIA: **C0G**

L×W (mm)	1.6×0.8				2.0×1.25				2.8×2.8		
最大T (mm)	0.8	0.9			0.95			1.0	1.35		
额定电压(Vdc)	250	100	50		100	50	250	500			
静电容量/温度特性代号	C0G	C0G	CΔ	C0G	CH	C0G	CΔ	C0G	CH	C0G	C0G
1.0pF	p115	p115	p116			p117	p118			p120	p121
2.0pF	p115	p116	p116			p118	p118			p120	p121
3.0pF	p115	p116	p116			p118	p118			p120	p121
4.0pF	p115	p116	p116			p118	p118			p120	p121
5.0pF	p115	p116	p116			p118	p118			p120	p121
6.0pF	p115	p116	p116			p118	p119			p120	p121
7.0pF	p115			p116	p117	p118	p119			p120	p121
8.0pF	p115			p116	p117	p118	p119			p120	p121
9.0pF	p115			p116	p117	p118	p119			p120	p121
10pF	p115			p116	p117	p118	p119			p120	p121
11pF	p115			p116	p117	p118	p119			p120	p121
12pF	p115			p116	p117	p118	p119			p120	p121
13pF	p115			p116	p117	p118	p119			p120	p121
15pF	p115			p116	p117	p118	p119			p120	p121
16pF	p115			p116	p117	p118	p119			p120	p121
18pF	p115			p117	p117	p118	p119			p120	p121
20pF	p115			p117	p117			p119	p119	p120	p121
22pF	p115			p117	p117			p119	p119	p120	p121
24pF	p115			p117	p117			p119	p119	p120	p121
27pF	p115			p117	p117			p119	p119	p120	p121
30pF	p115			p117	p117			p119	p119	p120	p121
33pF	p115			p117	p117			p119	p119	p120	p121
36pF	p115			p117	p117			p119	p119	p120	p121
39pF	p115			p117	p117			p119	p119	p120	p121
43pF	p115			p117	p117			p119	p119	p120	p121
47pF	p115			p117	p117			p119	p119	p120	p121
51pF				p117	p117			p119	p119	p120	p121
56pF				p117	p117			p119	p119	p120	p121
62pF				p117	p117			p119	p119	p120	p121
68pF				p117	p117			p119	p119	p120	p121
75pF				p117	p117			p119	p119	p120	p122
82pF				p117	p117			p119	p119	p120	p122
91pF				p117	p117			p119	p119	p120	p122
100pF				p117	p117			p119	p119	p121	p122

10pF以下，不标明每0.1pF的信息。
详情请参见品名列表。

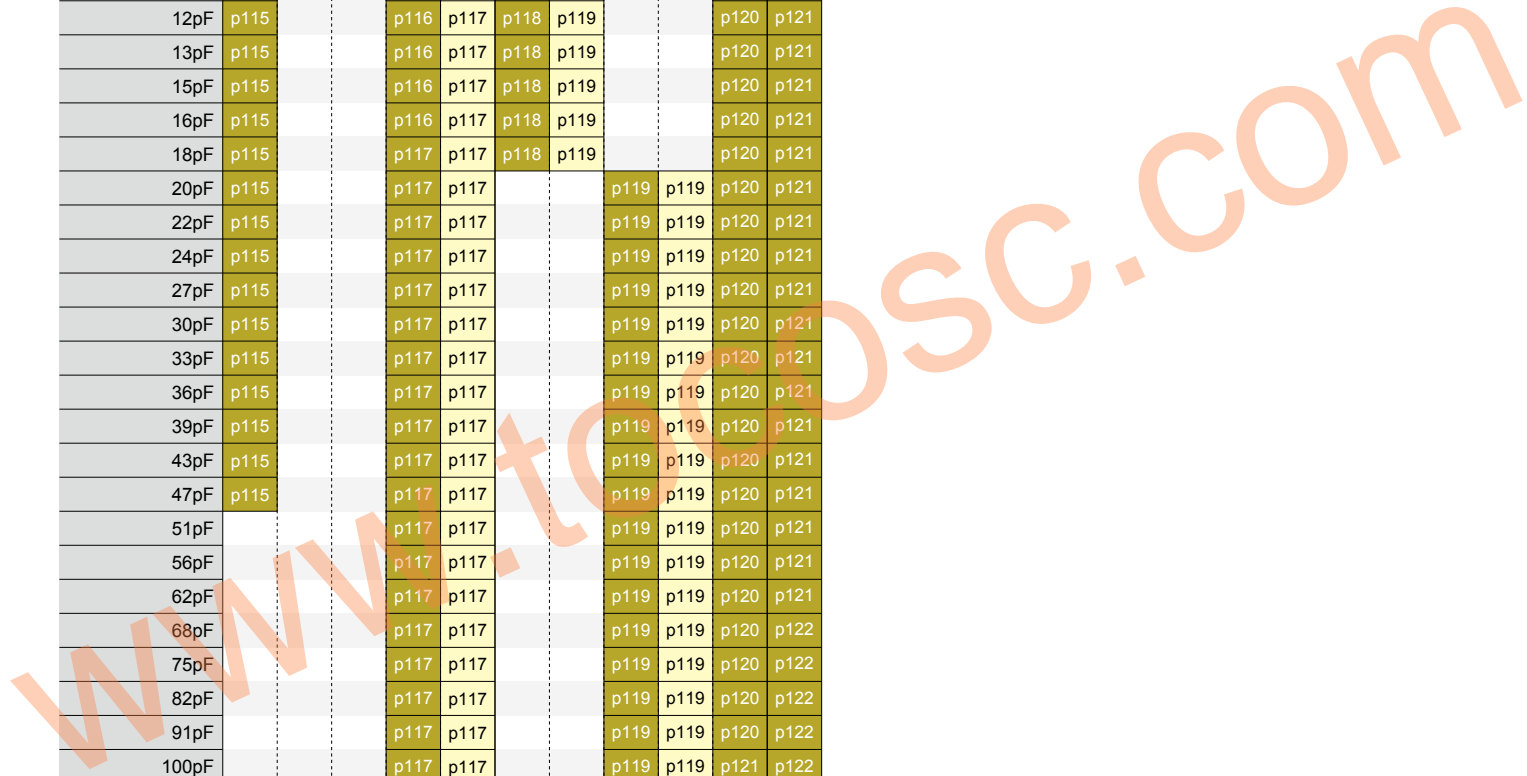

静电容量表

■ GRJ 系列高介电常数型

p00 ← 品名列表

EIA: X7R X7S

L×W (mm)	2.0×1.25		3.2×1.6						3.2×2.5												
	最大T (mm)	1.0	1.45	1.25			1.8			1.5			2.0			2.3	2.8				
额定电压(Vdc)	250	250	1000	630	250	1000	630	250	1000	630	250	1000	630	250	100	50	25	16	10	6.3	
静电容量/温度特性代号	X7R	X7R	X7R	X7R	X7R	X7R	X7R	X7R	X7R	X7R	X7R	X7R	X7R	X7R	X7R	X7R	X7S	X7R	X7R	X7R	X7R
470pF			p124																		
680pF			p124																		
1000pF	p124		p124	p124																	
1500pF	p124		p124	p124																	
2200pF	p124		p124	p124																	
3300pF	p124		p124	p124																	
4700pF	p124		p124	p124																	
6800pF	p124			p124		p124			p124												
10000pF		p124		p124		p124			p124												
15000pF		p124			p124		p124					p124									
22000pF		p124			p124		p124			p124			p124								
33000pF								p124						p124							
47000pF								p124						p124							
68000pF					p124						p124										
0.10μF								p124							p124						
0.15μF									p124												
0.22μF										p124											
0.33μF																					
0.47μF																					
0.68μF																					
1.0μF																					
2.2μF																p124					
4.7μF																p124					
10μF																	p124	p124			
22μF																		p124	p124		
47μF																					p124



L×W (mm)	4.5×3.2					5.7×5.0			
	最大T (mm)	1.5	2.0			2.0			
额定电压(Vdc)	630	250	1000	630	250	1000	630	250	
静电容量/温度特性代号	X7R	X7R	X7R	X7R	X7R	X7R	X7R	X7R	
33000pF			p124						
47000pF			p124						
68000pF	p124					p124			
0.10μF				p124		p124			
0.15μF		p124					p124		
0.22μF					p124		p124		
0.33μF						p124		p124	
0.47μF						p124		p124	
0.68μF								p124	
1.0μF								p124	

静电容量表

■ GR3 系列高介电常数型

p00 ← 品名列表 EIA: X7T

L×W (mm)	2.0×1.25		3.2×1.6						3.2×2.5					4.5×3.2			5.7×5.0								
	1.0	1.45	1.0		1.25		1.8		1.5		2.0			1.5	2.0		2.0		2.7						
额定电压(Vdc)	250	250	450	250	630	450	250	630	450	250	630	250	630	450	250	250	630	450	250	630	450	250	630	450	250
静电容量/温度特性代号	X7T	X7T	X7T	X7T	X7T	X7T	X7T	X7T	X7T	X7T	X7T	X7T	X7T	X7T	X7T	X7T	X7T	X7T	X7T	X7T	X7T	X7T	X7T	X7T	X7T
10000pF	p126		p126		p126																				
15000pF	p126		p126				p126																		
22000pF		p126			p126					p126															
33000pF				p126	p126								p126												
47000pF						p126		p126					p126												
68000pF									p126					p126											
0.10μF											p126			p126									p126		
0.15μF														p126									p126		
0.22μF															p126								p126		
0.27μF																								p126	
0.33μF																									p126
0.47μF																									
0.56μF																									
0.68μF																									
1.0μF																									



静电容量表

■ KRM 系列高介电常数型

p00 ← 品名列表 EIA: X7R X6S X5R

L×W (mm)	3.5×1.7					3.6×1.7	3.7×1.85	6.1×5.3															
	2.0	2.9				2.9	2.9	3.0						3.9					5.0				
额定电压(Vdc)	25	100	50	35	25	50	100	1000	630	250	100	63	50	35	25	100	63	50	35	25	1000	630	
静电容量/温度特性代号	X5R	X7R	X7R	X6S	X6S	X7R	X7R	X7R	X7R	X7R	X7R	X7R	X7R	X7R	X7R	X7R	X7R	X7R	X7R	X7R	X7R	X7R	X7R
68000pF								p129															
0.10μF								p129															
0.15μF									p129														p129
0.22μF									p129														p129
0.33μF																							p129
0.47μF																							p129
0.68μF																							
1.0μF		p129																					
1.5μF																							
2.2μF							p129	p129															
4.7μF			p129																				
6.8μF																							
10μF	p129			p129	p129																		
15μF																							
17μF																							
22μF																							
33μF																							
47μF																							
68μF																							



L×W (mm)	6.1×5.3									
	5.0					6.7				
最大T (mm)	2.0					2.9				
额定电压(Vdc)	250	100	50	35	25	100	63	50	35	25
静电容量/温度特性代号	X7R	X7R	X7R	X7R	X7R	X7R	X7R	X7R	X7R	X7R
68000pF										
0.10μF										
0.15μF										
0.22μF										
0.33μF										
0.47μF										
0.68μF										
1.0μF										
1.5μF	p129									
2.2μF	p129									
4.7μF										
6.8μF										
10μF		p129								
15μF						p129				
17μF										
22μF			p129	p129			p129			
33μF				p129	p129			p129		
47μF									p129	p129
68μF										p129

静电容量表

■ KR3 系列高介电常数型

p00 ← 品名列表

EIA: X7T

L×W (mm)	6.1×5.3										
	3.0			3.9			5.0		6.7		
最大T (mm)	3.0	450	250	630	450	250	450	250	630	450	250
额定电压(Vdc)	630	450	250	630	450	250	450	250	630	450	250
静电容量/温度特性代号	X7T	X7T	X7T	X7T	X7T	X7T	X7T	X7T	X7T	X7T	X7T
0.10μF	p132										
0.15μF	p132										
0.22μF		p132		p132							
0.27μF				p132							
0.33μF		p132									
0.47μF		p132	p132						p132		
0.56μF				p132					p132		
0.68μF			p132				p132				
1.0μF						p132	p132				
1.2μF										p132	
1.5μF								p132			
2.2μF											p132

■ LLA 系列高介电常数型

p00 ← 品名列表

EIA: X7R X7S

L×W (mm)	1.6×0.8	2.0×1.25									3.2×1.6							
	0.55	0.55					0.95				0.55				0.95		1.25	
最大T (mm)	4	25	16	10	6.3	4	25	16	10	6.3	4	16	10	6.3	16	10	16	10
额定电压(Vdc)	4	25	16	10	6.3	4	25	16	10	6.3	4	16	10	6.3	16	10	16	10
静电容量/温度特性代号	X7S	X7R	X7R	X7R	X7R	X7S	X7R	X7R	X7R	X7R	X7S	X7R	X7R	X7R	X7R	X7R	X7R	X7R
10000pF		p134								p134								
22000pF		p134								p134								
47000pF			p134							p134								
0.10μF	p134		p134							p134								
0.22μF	p134			p134						p134			p134					
0.47μF	p134				p134					p134				p134		p134		
1.0μF						p134					p134				p134		p134	
2.2μF	p134											p134			p134			p134
4.7μF						p134												p134

静电容量表

■ LLL 系列高介电常数型

p00 ← 品名列表 EIA: X7R X7S X6S X5R

L×W (mm)	0.5×1.0			0.8×1.6										1.25×2.0									
	最大T (mm)			0.5				0.55	0.6					0.5				0.7					
额定电压(Vdc)	6.3	4		4	25	16	10	4	4	50	25	16	10	4	50	25	16	10	6.3	4	50	25	
静电容量/温度特性代号	X6S	X7S	X6S	X5R	X7R	X7R	X7R	X7S	X7R	X7R	X7R	X7R	X7S	X7R	X7R	X7R	X7R	X7R	X7S	X7R	X7R	X7R	
2200pF										p136													
4700pF										p136													
10000pF					p136						p136				p136							p136	
22000pF						p136					p136					p136						p136	
47000pF							p136					p136					p136						p136
0.10μF	p136						p136					p136					p136						p136
0.22μF	p136							p136					p136					p136					p136
0.47μF		p136												p136									p136
1.0μF			p136																				p136
2.2μF									p136														
4.3μF																							
4.7μF																							
10μF																							



L×W (mm)	1.25×2.0				1.6×3.2																		
	0.7		0.95		0.5				0.8				1.25										
额定电压(Vdc)	10	16	10	4	50	25	16	10	50	25	16	10	6.3	50	25	16	10	6.3					
静电容量/温度特性代号	X7R	X7R	X7R	X7S	X7R	X7R	X7R	X7R	X7R	X7R	X7R	X7R	X7R	X7R	X7R	X7R	X7R	X7R	X7R	X5R			
2200pF																							
4700pF																							
10000pF					p136					p136													
22000pF					p136					p136													
47000pF						p136				p136													
0.10μF						p136				p136					p136								
0.22μF	p136	p136					p136				p136					p136							
0.47μF			p136					p136				p136					p136						
1.0μF			p136									p136						p136					
2.2μF				p136									p136						p136				
4.3μF																							
4.7μF																						p136	
10μF																							p136

■ LLM 系列高介电常数型

p00 ← 品名列表 EIA: X7R X7S

L×W (mm)	2.0×1.25		3.2×1.6		
	最大T (mm)		0.55		
额定电压(Vdc)	6.3	4	16	10	6.3
静电容量/温度特性代号	X7R	X7S	X7R	X7R	X7R
0.10μF			p138		
0.22μF	p138		p138		
0.47μF	p138			p138	
1.0μF		p138			
2.2μF					p138

■ LLR 系列高介电常数型

p00 ← 品名列表 EIA: X7S

L×W (mm)	0.8×1.6			
最大T (mm)	0.55			
额定电压(Vdc)	4			
温度特性代号	X7S			
静电容量/ESR (mΩ)	100	220	470	1000
1.0μF	p140	p140	p140	p140

查找电容器

规格和测试方法、包装、特性数据图表请通过搜索网站中有关页面获取。
<http://www.murata.com/products/capacitor/>

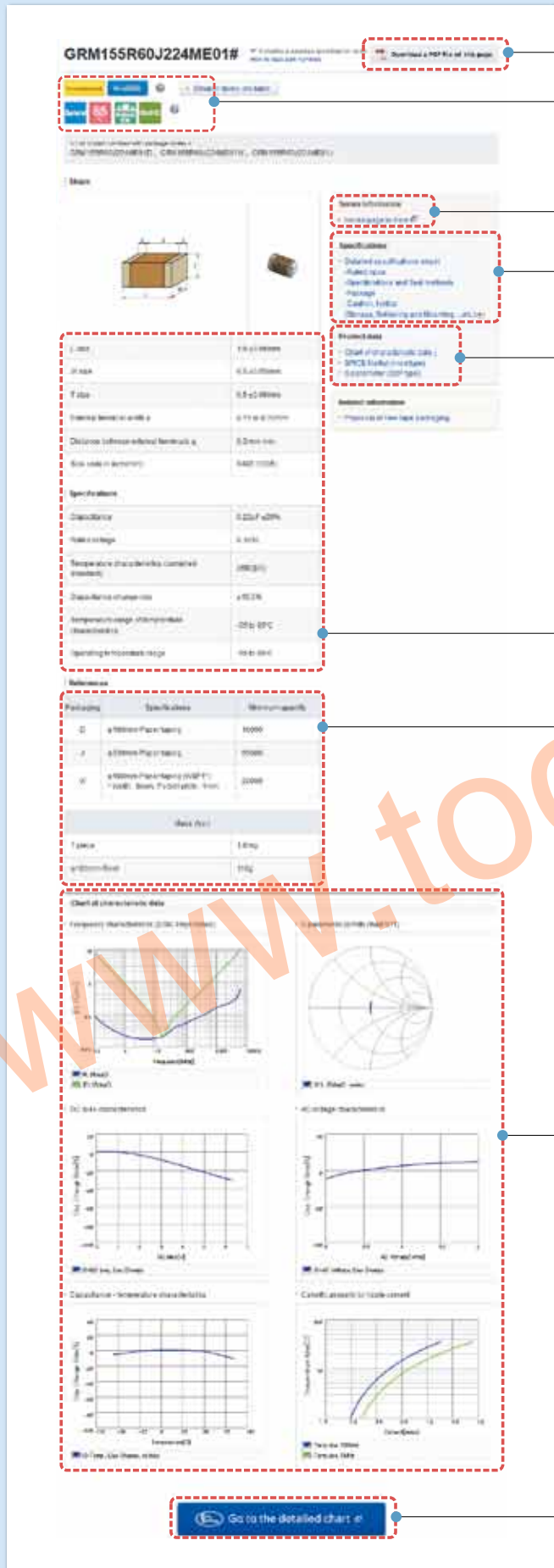

数据表

产品详细信息页面可以PDF格式输出。

状态和特点图标

可立即查阅产品的状态和特点。单击后，将显示每个图标的说明。单击 ? 后，将显示每个图标的说明。

特性 & 应用

该链接跳至各系列的简介页面。

详细规格表

- 额定值
- 规格和测试方法
- 包装
- 警告/注意事项
(存放、焊接和贴装等)

特性数据

可获取主要产品的以下特性数据。

- SPICE网表 (Mod 型)
- S 参数 (S2P 型)
- 可靠性测试数据*典型数据

- 形状 (尺寸)
- 额定值

- 按包装代码/起订量的规格
- 重量 (1 pc/ø180mm 卷装)

特性数据图表

公布的主要产品的特性数据。

- 频率特性 (ESR、阻抗)
- S参数 (史密斯图S11)
- 直流偏置特性
- 交流电压特性
- 静电容量 - 温度特性
- 纹波电流产生的热学性能

设计工具 SimSurfing

SimSurfing设计工具可用于显示图表、下载CSV数据和覆盖产品编号图。

一般用

GRM 系列



这款采用最新先进技术的村田主要产品因小尺寸和超大电容值而闻名。

特点

① 多层结构的使用获得了超大电容和小尺寸。

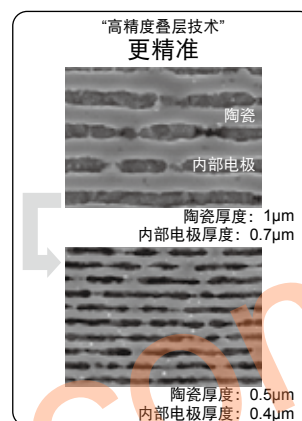
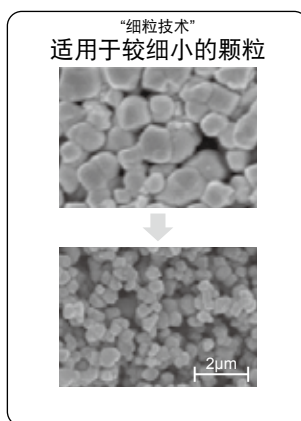
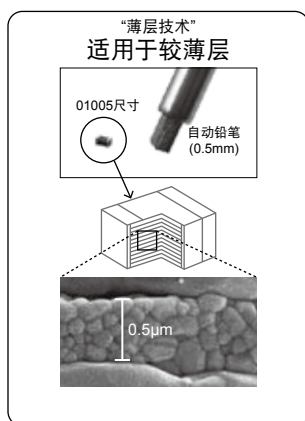
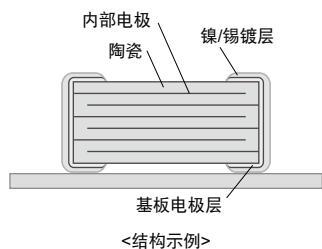

② 可在外部电极上锡镀，优良的焊接性能。

③ 可靠性高，无极性。

	陶瓷电容器	钽电容器	铝电解电容器	导电性高分子电容器
价格	○	○	◎	○
阻抗频率特性比较	◎	△	△	○
静电容量温度特性	○	◎	○	○
直流击穿电压	◎	△	△	△
极性	无	有	有	有
脉冲响应	◎	△	△	○
容许纹波电流	◎	△	△	△
可靠性	◎	○	○	○
直流偏置特性	△	◎	◎	◎

◎: 极佳 ○: 卓越 △: 一般

规格

尺寸	0.4×0.2mm 到 5.7×5.0mm
额定电压	DC2.5V 到 3.15kV
静电容量	0.1pF to 220µF
主要应用	1. 额定电压最大值100V 高介电常数型···用于去耦和平滑电路 温度补偿型···用于调谐电路、振荡电路和高频滤波电路 2. 额定电压最小值200V 高介电常数型···用于箝位电路和平滑电路 温度补偿型···电源阻尼器

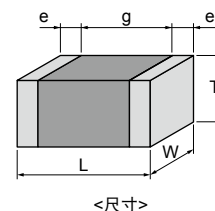

本目录仅列出了部分产品系列。
 详情请参阅村田网站中的电容器检索工具。

GRM 系列温度补偿型品名列表

■ 0.4×0.2mm **超小型**

T 最大值	额定 电压	温度特 性代号	静电容量	公差	品名
0.22mm	16Vdc	C0G	0.20pF	±0.05pF	GRM0225C1CR20WA02#
				±0.1pF	GRM0225C1CR20BA02#
			0.30pF	±0.05pF	GRM0225C1CR30WA02#
				±0.1pF	GRM0225C1CR30BA02#
			0.40pF	±0.05pF	GRM0225C1CR40WA02#
				±0.1pF	GRM0225C1CR40BA02#
			0.50pF	±0.05pF	GRM0225C1CR50WA02#
				±0.1pF	GRM0225C1CR50BA02#
			0.60pF	±0.05pF	GRM0225C1CR60WA02#
				±0.1pF	GRM0225C1CR60BA02#
			0.70pF	±0.05pF	GRM0225C1CR70WA02#
				±0.1pF	GRM0225C1CR70BA02#
			0.80pF	±0.05pF	GRM0225C1CR80WA02#
				±0.1pF	GRM0225C1CR80BA02#
			0.90pF	±0.05pF	GRM0225C1CR90WA02#
				±0.1pF	GRM0225C1CR90BA02#
			1.0pF	±0.05pF	GRM0225C1C1R0WA02#
				±0.1pF	GRM0225C1C1R0BA02#
				±0.25pF	GRM0225C1C1R0CA02#
			1.1pF	±0.05pF	GRM0225C1C1R1WA02#
				±0.1pF	GRM0225C1C1R1BA02#
				±0.25pF	GRM0225C1C1R1CA02#
			1.2pF	±0.05pF	GRM0225C1C1R2WA02#
				±0.1pF	GRM0225C1C1R2BA02#
				±0.25pF	GRM0225C1C1R2CA02#
			1.3pF	±0.05pF	GRM0225C1C1R3WA02#
				±0.1pF	GRM0225C1C1R3BA02#
				±0.25pF	GRM0225C1C1R3CA02#
			1.4pF	±0.05pF	GRM0225C1C1R4WA02#
				±0.1pF	GRM0225C1C1R4BA02#
				±0.25pF	GRM0225C1C1R4CA02#
			1.5pF	±0.05pF	GRM0225C1C1R5WA02#
				±0.1pF	GRM0225C1C1R5BA02#
				±0.25pF	GRM0225C1C1R5CA02#
			1.6pF	±0.05pF	GRM0225C1C1R6WA02#
				±0.1pF	GRM0225C1C1R6BA02#
				±0.25pF	GRM0225C1C1R6CA02#
			1.7pF	±0.05pF	GRM0225C1C1R7WA02#
				±0.1pF	GRM0225C1C1R7BA02#
				±0.25pF	GRM0225C1C1R7CA02#
			1.8pF	±0.05pF	GRM0225C1C1R8WA02#
				±0.1pF	GRM0225C1C1R8BA02#
				±0.25pF	GRM0225C1C1R8CA02#
			1.9pF	±0.05pF	GRM0225C1C1R9WA02#
				±0.1pF	GRM0225C1C1R9BA02#
				±0.25pF	GRM0225C1C1R9CA02#
			2.0pF	±0.05pF	GRM0225C1C2R0WA02#
				±0.1pF	GRM0225C1C2R0BA02#
±0.25pF	GRM0225C1C2R0CA02#				
2.1pF	±0.05pF	GRM0225C1C2R1WA02#			
	±0.1pF	GRM0225C1C2R1BA02#			
	±0.25pF	GRM0225C1C2R1CA02#			

T 最大值	额定 电压	温度特 性代号	静电容量	公差	品名
0.22mm	16Vdc	C0G	2.2pF	±0.05pF	GRM0225C1C2R2WA02#
				±0.1pF	GRM0225C1C2R2BA02#
				±0.25pF	GRM0225C1C2R2CA02#
			2.3pF	±0.05pF	GRM0225C1C2R3WA02#
				±0.1pF	GRM0225C1C2R3BA02#
				±0.25pF	GRM0225C1C2R3CA02#
			2.4pF	±0.05pF	GRM0225C1C2R4WA02#
				±0.1pF	GRM0225C1C2R4BA02#
				±0.25pF	GRM0225C1C2R4CA02#
			2.5pF	±0.05pF	GRM0225C1C2R5WA02#
				±0.1pF	GRM0225C1C2R5BA02#
				±0.25pF	GRM0225C1C2R5CA02#
			2.6pF	±0.05pF	GRM0225C1C2R6WA02#
				±0.1pF	GRM0225C1C2R6BA02#
				±0.25pF	GRM0225C1C2R6CA02#
			2.7pF	±0.05pF	GRM0225C1C2R7WA02#
				±0.1pF	GRM0225C1C2R7BA02#
				±0.25pF	GRM0225C1C2R7CA02#
			2.8pF	±0.05pF	GRM0225C1C2R8WA02#
				±0.1pF	GRM0225C1C2R8BA02#
				±0.25pF	GRM0225C1C2R8CA02#
			2.9pF	±0.05pF	GRM0225C1C2R9WA02#
				±0.1pF	GRM0225C1C2R9BA02#
				±0.25pF	GRM0225C1C2R9CA02#
			3.0pF	±0.05pF	GRM0225C1C3R0WA02#
				±0.1pF	GRM0225C1C3R0BA02#
				±0.25pF	GRM0225C1C3R0CA02#
			3.1pF	±0.05pF	GRM0225C1C3R1WA02#
				±0.1pF	GRM0225C1C3R1BA02#
				±0.25pF	GRM0225C1C3R1CA02#
			3.2pF	±0.05pF	GRM0225C1C3R2WA02#
				±0.1pF	GRM0225C1C3R2BA02#
				±0.25pF	GRM0225C1C3R2CA02#
			3.3pF	±0.05pF	GRM0225C1C3R3WA02#
				±0.1pF	GRM0225C1C3R3BA02#
				±0.25pF	GRM0225C1C3R3CA02#
			3.4pF	±0.05pF	GRM0225C1C3R4WA02#
				±0.1pF	GRM0225C1C3R4BA02#
				±0.25pF	GRM0225C1C3R4CA02#
			3.5pF	±0.05pF	GRM0225C1C3R5WA02#
				±0.1pF	GRM0225C1C3R5BA02#
				±0.25pF	GRM0225C1C3R5CA02#
			3.6pF	±0.05pF	GRM0225C1C3R6WA02#
				±0.1pF	GRM0225C1C3R6BA02#
				±0.25pF	GRM0225C1C3R6CA02#
			3.7pF	±0.05pF	GRM0225C1C3R7WA02#
				±0.1pF	GRM0225C1C3R7BA02#
				±0.25pF	GRM0225C1C3R7CA02#
3.8pF	±0.05pF	GRM0225C1C3R8WA02#			
	±0.1pF	GRM0225C1C3R8BA02#			
	±0.25pF	GRM0225C1C3R8CA02#			
3.9pF	±0.05pF	GRM0225C1C3R9WA02#			
	±0.1pF	GRM0225C1C3R9BA02#			
	±0.25pF	GRM0225C1C3R9CA02#			

品名 # 表示包装规格代码。

- GRM 系列
- GJM 系列
- GMA 系列
- GMD 系列
- GQM 系列
- GRJ 系列
- GR3 系列
- KRM 系列
- KR3 系列
- LJA 系列
- LLL 系列
- LJM 系列
- LLR 系列
- 警告 / 注意事项

GRM 系列温度补偿型品名列表

(→ ■ 0.4×0.2mm)

T 最大值	额定 电压	温度特 性代号	静电容量	公差	品名
0.22mm	16Vdc	C0G	4.0pF	±0.05pF	GRM0225C1C4R0WA02#
				±0.1pF	GRM0225C1C4R0BA02#
				±0.25pF	GRM0225C1C4R0CA02#
			4.1pF	±0.05pF	GRM0225C1C4R1WA02#
				±0.1pF	GRM0225C1C4R1BA02#
				±0.25pF	GRM0225C1C4R1CA02#
			4.2pF	±0.05pF	GRM0225C1C4R2WA02#
				±0.1pF	GRM0225C1C4R2BA02#
				±0.25pF	GRM0225C1C4R2CA02#
			4.3pF	±0.05pF	GRM0225C1C4R3WA02#
				±0.1pF	GRM0225C1C4R3BA02#
				±0.25pF	GRM0225C1C4R3CA02#
			4.4pF	±0.05pF	GRM0225C1C4R4WA02#
				±0.1pF	GRM0225C1C4R4BA02#
				±0.25pF	GRM0225C1C4R4CA02#
			4.5pF	±0.05pF	GRM0225C1C4R5WA02#
				±0.1pF	GRM0225C1C4R5BA02#
				±0.25pF	GRM0225C1C4R5CA02#
			4.6pF	±0.05pF	GRM0225C1C4R6WA02#
				±0.1pF	GRM0225C1C4R6BA02#
				±0.25pF	GRM0225C1C4R6CA02#
			4.7pF	±0.05pF	GRM0225C1C4R7WA02#
				±0.1pF	GRM0225C1C4R7BA02#
				±0.25pF	GRM0225C1C4R7CA02#
			4.8pF	±0.05pF	GRM0225C1C4R8WA02#
				±0.1pF	GRM0225C1C4R8BA02#
				±0.25pF	GRM0225C1C4R8CA02#
			4.9pF	±0.05pF	GRM0225C1C4R9WA02#
				±0.1pF	GRM0225C1C4R9BA02#
				±0.25pF	GRM0225C1C4R9CA02#
			5.0pF	±0.05pF	GRM0225C1C5R0WA02#
				±0.1pF	GRM0225C1C5R0BA02#
				±0.25pF	GRM0225C1C5R0CA02#
			5.1pF	±0.05pF	GRM0225C1C5R1WA02#
				±0.1pF	GRM0225C1C5R1BA02#
				±0.25pF	GRM0225C1C5R1CA02#
			5.2pF	±0.05pF	GRM0225C1C5R2WA02#
				±0.1pF	GRM0225C1C5R2BA02#
				±0.25pF	GRM0225C1C5R2CA02#
			5.3pF	±0.05pF	GRM0225C1C5R3WA02#
				±0.1pF	GRM0225C1C5R3BA02#
				±0.25pF	GRM0225C1C5R3CA02#
			5.4pF	±0.05pF	GRM0225C1C5R4WA02#
				±0.1pF	GRM0225C1C5R4BA02#
				±0.25pF	GRM0225C1C5R4CA02#
			5.5pF	±0.05pF	GRM0225C1C5R5WA02#
				±0.1pF	GRM0225C1C5R5BA02#
				±0.25pF	GRM0225C1C5R5CA02#
			5.6pF	±0.05pF	GRM0225C1C5R6WA02#
				±0.1pF	GRM0225C1C5R6BA02#
				±0.25pF	GRM0225C1C5R6CA02#

T 最大值	额定 电压	温度特 性代号	静电容量	公差	品名
0.22mm	16Vdc	C0G	5.6pF	±0.1pF	GRM0225C1C5R6BA02#
				±0.25pF	GRM0225C1C5R6CA02#
				±0.5pF	GRM0225C1C5R6DA02#
			5.7pF	±0.05pF	GRM0225C1C5R7WA02#
				±0.1pF	GRM0225C1C5R7BA02#
				±0.25pF	GRM0225C1C5R7CA02#
			5.8pF	±0.05pF	GRM0225C1C5R8WA02#
				±0.1pF	GRM0225C1C5R8BA02#
				±0.25pF	GRM0225C1C5R8CA02#
			5.9pF	±0.05pF	GRM0225C1C5R9WA02#
				±0.1pF	GRM0225C1C5R9BA02#
				±0.25pF	GRM0225C1C5R9CA02#
			6.0pF	±0.05pF	GRM0225C1C6R0WA02#
				±0.1pF	GRM0225C1C6R0BA02#
				±0.25pF	GRM0225C1C6R0CA02#
			6.1pF	±0.05pF	GRM0225C1C6R1WA02#
				±0.1pF	GRM0225C1C6R1BA02#
				±0.25pF	GRM0225C1C6R1CA02#
			6.2pF	±0.05pF	GRM0225C1C6R2WA02#
				±0.1pF	GRM0225C1C6R2BA02#
				±0.25pF	GRM0225C1C6R2CA02#
			6.3pF	±0.05pF	GRM0225C1C6R3WA02#
				±0.1pF	GRM0225C1C6R3BA02#
				±0.25pF	GRM0225C1C6R3CA02#
			6.4pF	±0.05pF	GRM0225C1C6R4WA02#
				±0.1pF	GRM0225C1C6R4BA02#
				±0.25pF	GRM0225C1C6R4CA02#
			6.5pF	±0.05pF	GRM0225C1C6R5WA02#
				±0.1pF	GRM0225C1C6R5BA02#
				±0.25pF	GRM0225C1C6R5CA02#
			6.6pF	±0.05pF	GRM0225C1C6R6WA02#
				±0.1pF	GRM0225C1C6R6BA02#
				±0.25pF	GRM0225C1C6R6CA02#
			6.7pF	±0.05pF	GRM0225C1C6R7WA02#
				±0.1pF	GRM0225C1C6R7BA02#
				±0.25pF	GRM0225C1C6R7CA02#
			6.8pF	±0.05pF	GRM0225C1C6R8WA02#
				±0.1pF	GRM0225C1C6R8BA02#
				±0.25pF	GRM0225C1C6R8CA02#
			6.9pF	±0.05pF	GRM0225C1C6R9WA02#
				±0.1pF	GRM0225C1C6R9BA02#
				±0.25pF	GRM0225C1C6R9CA02#

品名 # 表示包装规格代码。

GRM 系列
GJM 系列
GMA 系列
GMD 系列
GQM 系列
GRJ 系列
GR3 系列
KRM 系列
KR3 系列
LLA 系列
LLL 系列
LLM 系列
LLR 系列
警告/注意事项

GRM 系列温度补偿型品名列表

(→ ■ 0.4×0.2mm)

T 最大值	额定 电压	温度特 性代号	静电容量	公差	品名
0.22mm	16Vdc	C0G	6.9pF	±0.5pF	GRM0225C1C6R9DA02#
				±0.05pF	GRM0225C1C7R0WA02#
					±0.1pF
			±0.25pF		GRM0225C1C7R0CA02#
			7.0pF	±0.5pF	GRM0225C1C7R0DA02#
				±0.05pF	GRM0225C1C7R1WA02#
					±0.1pF
			±0.25pF		GRM0225C1C7R1CA02#
			7.1pF	±0.5pF	GRM0225C1C7R1DA02#
				±0.05pF	GRM0225C1C7R2WA02#
					±0.1pF
			±0.25pF		GRM0225C1C7R2CA02#
			7.2pF	±0.5pF	GRM0225C1C7R2DA02#
				±0.05pF	GRM0225C1C7R3WA02#
					±0.1pF
			±0.25pF		GRM0225C1C7R3CA02#
			7.3pF	±0.5pF	GRM0225C1C7R3DA02#
				±0.05pF	GRM0225C1C7R4WA02#
					±0.1pF
			±0.25pF		GRM0225C1C7R4CA02#
			7.4pF	±0.5pF	GRM0225C1C7R4DA02#
				±0.05pF	GRM0225C1C7R5WA02#
					±0.1pF
			±0.25pF		GRM0225C1C7R5CA02#
			7.5pF	±0.5pF	GRM0225C1C7R5DA02#
				±0.05pF	GRM0225C1C7R6WA02#
					±0.1pF
			±0.25pF		GRM0225C1C7R6CA02#
			7.6pF	±0.5pF	GRM0225C1C7R6DA02#
				±0.05pF	GRM0225C1C7R7WA02#
					±0.1pF
			±0.25pF		GRM0225C1C7R7CA02#
			7.7pF	±0.5pF	GRM0225C1C7R7DA02#
				±0.05pF	GRM0225C1C7R8WA02#
					±0.1pF
			±0.25pF		GRM0225C1C7R8CA02#
			7.8pF	±0.5pF	GRM0225C1C7R8DA02#
				±0.05pF	GRM0225C1C7R9WA02#
					±0.1pF
			±0.25pF		GRM0225C1C7R9CA02#
			7.9pF	±0.5pF	GRM0225C1C7R9DA02#
				±0.05pF	GRM0225C1C8R0WA02#
					±0.1pF
			±0.25pF		GRM0225C1C8R0CA02#
			8.0pF	±0.5pF	GRM0225C1C8R0DA02#
				±0.05pF	GRM0225C1C8R1WA02#
					±0.1pF
			±0.25pF		GRM0225C1C8R1CA02#
			8.1pF	±0.5pF	GRM0225C1C8R1DA02#
				±0.05pF	GRM0225C1C8R2WA02#
					±0.1pF
			±0.25pF		GRM0225C1C8R2CA02#
			8.2pF	±0.5pF	GRM0225C1C8R2DA02#
				±0.05pF	GRM0225C1C8R3WA02#

T 最大值	额定 电压	温度特 性代号	静电容量	公差	品名
0.22mm	16Vdc	C0G	8.3pF	±0.1pF	GRM0225C1C8R3BA02#
				±0.25pF	GRM0225C1C8R3CA02#
				±0.5pF	GRM0225C1C8R3DA02#
			8.4pF	±0.05pF	GRM0225C1C8R4WA02#
				±0.1pF	GRM0225C1C8R4BA02#
				±0.25pF	GRM0225C1C8R4CA02#
			8.5pF	±0.5pF	GRM0225C1C8R4DA02#
				±0.05pF	GRM0225C1C8R5WA02#
					±0.1pF
			±0.25pF		GRM0225C1C8R5CA02#
			8.6pF	±0.5pF	GRM0225C1C8R5DA02#
				±0.05pF	GRM0225C1C8R6WA02#
					±0.1pF
			±0.25pF		GRM0225C1C8R6CA02#
			8.7pF	±0.5pF	GRM0225C1C8R6DA02#
				±0.05pF	GRM0225C1C8R7WA02#
					±0.1pF
			±0.25pF		GRM0225C1C8R7CA02#
			8.8pF	±0.5pF	GRM0225C1C8R7DA02#
				±0.05pF	GRM0225C1C8R8WA02#
					±0.1pF
			±0.25pF		GRM0225C1C8R8CA02#
			8.9pF	±0.5pF	GRM0225C1C8R8DA02#
				±0.05pF	GRM0225C1C8R9WA02#
					±0.1pF
			±0.25pF		GRM0225C1C8R9CA02#
			9.0pF	±0.5pF	GRM0225C1C8R9DA02#
				±0.05pF	GRM0225C1C9R0WA02#
					±0.1pF
			±0.25pF		GRM0225C1C9R0CA02#
			9.1pF	±0.5pF	GRM0225C1C9R0DA02#
				±0.05pF	GRM0225C1C9R1WA02#
					±0.1pF
			±0.25pF		GRM0225C1C9R1CA02#
			9.2pF	±0.5pF	GRM0225C1C9R1DA02#
				±0.05pF	GRM0225C1C9R2WA02#
					±0.1pF
			±0.25pF		GRM0225C1C9R2CA02#
			9.3pF	±0.5pF	GRM0225C1C9R2DA02#
				±0.05pF	GRM0225C1C9R3WA02#
					±0.1pF
			±0.25pF		GRM0225C1C9R3CA02#
			9.4pF	±0.5pF	GRM0225C1C9R3DA02#
				±0.05pF	GRM0225C1C9R4WA02#
					±0.1pF
			±0.25pF		GRM0225C1C9R4CA02#
			9.5pF	±0.5pF	GRM0225C1C9R4DA02#
				±0.05pF	GRM0225C1C9R5WA02#
					±0.1pF
			±0.25pF		GRM0225C1C9R5CA02#
			9.6pF	±0.5pF	GRM0225C1C9R5DA02#
				±0.05pF	GRM0225C1C9R6WA02#
					±0.1pF
			±0.25pF		GRM0225C1C9R6CA02#

品名 # 表示包装规格代码。

- GRM 系列
- GJM 系列
- GMA 系列
- GMD 系列
- GQM 系列
- GRJ 系列
- GR3 系列
- KRM 系列
- KR3 系列
- LJA 系列
- LLL 系列
- LLM 系列
- LLR 系列
- 警告 / 注意事項

GRM 系列温度补偿型品名列表

(→ ■ 0.4×0.2mm)

T 最大值	额定 电压	温度特 性代号	静电容量	公差	品名
0.22mm	16Vdc	COG	9.6pF	±0.5pF	GRM0225C1C9R6DA02#
				±0.05pF	GRM0225C1C9R7WA02#
			9.7pF	±0.1pF	GRM0225C1C9R7BA02#
				±0.25pF	GRM0225C1C9R7CA02#
				±0.5pF	GRM0225C1C9R7DA02#
			9.8pF	±0.05pF	GRM0225C1C9R8WA02#
				±0.1pF	GRM0225C1C9R8BA02#
				±0.25pF	GRM0225C1C9R8CA02#
				±0.5pF	GRM0225C1C9R8DA02#
			9.9pF	±0.05pF	GRM0225C1C9R9WA02#
				±0.1pF	GRM0225C1C9R9BA02#
				±0.25pF	GRM0225C1C9R9CA02#
				±0.5pF	GRM0225C1C9R9DA02#
			10pF	±2%	GRM0225C1C100GA02#
				±5%	GRM0225C1C100JA02#
			11pF	±2%	GRM0225C1C110GA02#
				±5%	GRM0225C1C110JA02#
			12pF	±2%	GRM0225C1C120GA02#
				±5%	GRM0225C1C120JA02#
			13pF	±2%	GRM0225C1C130GA02#
				±5%	GRM0225C1C130JA02#
			14pF	±2%	GRM0225C1C140GA02#
				±5%	GRM0225C1C140JA02#
			15pF	±2%	GRM0225C1C150GA02#
				±5%	GRM0225C1C150JA02#
			16pF	±2%	GRM0225C1C160GA02#
				±5%	GRM0225C1C160JA02#
			17pF	±5%	GRM0225C1C170JA02#
				18pF	±2%
			±5%		GRM0225C1C180JA02#
			20pF	±2%	GRM0225C1C200GA02#
				±5%	GRM0225C1C200JA02#
			22pF	±2%	GRM0225C1C220GA02#
				±5%	GRM0225C1C220JA02#
			24pF	±2%	GRM0225C1C240GA02#
				±5%	GRM0225C1C240JA02#
			27pF	±2%	GRM0225C1C270GA02#
				±5%	GRM0225C1C270JA02#
			30pF	±2%	GRM0225C1C300GA02#
				±5%	GRM0225C1C300JA02#
			33pF	±2%	GRM0225C1C330GA02#
				±5%	GRM0225C1C330JA02#
			36pF	±2%	GRM0225C1C360GA02#
				±5%	GRM0225C1C360JA02#
			39pF	±2%	GRM0225C1C390GA02#
				±5%	GRM0225C1C390JA02#
			43pF	±2%	GRM0225C1C430GA02#
				±5%	GRM0225C1C430JA02#
			47pF	±2%	GRM0225C1C470GA02#
				±5%	GRM0225C1C470JA02#
51pF	±2%	GRM0225C1C510GA02#			
	±5%	GRM0225C1C510JA02#			
56pF	±2%	GRM0225C1C560GA02#			
	±5%	GRM0225C1C560JA02#			

T 最大值	额定 电压	温度特 性代号	静电容量	公差	品名	
0.22mm	16Vdc	COG	62pF	±2%	GRM0225C1C620GA02#	
				±5%	GRM0225C1C620JA02#	
			68pF	±2%	GRM0225C1C680GA02#	
				±5%	GRM0225C1C680JA02#	
			75pF	±2%	GRM0225C1C750GA02#	
				±5%	GRM0225C1C750JA02#	
			82pF	±2%	GRM0225C1C820GA02#	
				±5%	GRM0225C1C820JA02#	
			91pF	±2%	GRM0225C1C910GA02#	
				±5%	GRM0225C1C910JA02#	
			94pF	±5%	GRM0225C1C940JA02#	
				96pF	±5%	GRM0225C1C960JA02#
			100pF		±2%	GRM0225C1C101GA02#
				±5%	GRM0225C1C101JA02#	
			CK	0.20pF	±0.05pF	GRM0224C1CR20WA02#
					±0.1pF	GRM0224C1CR20BA02#
				0.30pF	±0.05pF	GRM0224C1CR30WA02#
					±0.1pF	GRM0224C1CR30BA02#
				0.40pF	±0.05pF	GRM0224C1CR40WA02#
					±0.1pF	GRM0224C1CR40BA02#
				0.50pF	±0.05pF	GRM0224C1CR50WA02#
					±0.1pF	GRM0224C1CR50BA02#
				0.60pF	±0.05pF	GRM0224C1CR60WA02#
					±0.1pF	GRM0224C1CR60BA02#
				0.70pF	±0.05pF	GRM0224C1CR70WA02#
		±0.1pF			GRM0224C1CR70BA02#	
		0.80pF		±0.05pF	GRM0224C1CR80WA02#	
				±0.1pF	GRM0224C1CR80BA02#	
		0.90pF		±0.05pF	GRM0224C1CR90WA02#	
				±0.1pF	GRM0224C1CR90BA02#	
		1.0pF		±0.05pF	GRM0224C1C1R0WA02#	
				±0.1pF	GRM0224C1C1R0BA02#	
				±0.25pF	GRM0224C1C1R0CA02#	
		1.1pF		±0.05pF	GRM0224C1C1R1WA02#	
				±0.1pF	GRM0224C1C1R1BA02#	
				±0.25pF	GRM0224C1C1R1CA02#	
		1.2pF		±0.05pF	GRM0224C1C1R2WA02#	
				±0.1pF	GRM0224C1C1R2BA02#	
				±0.25pF	GRM0224C1C1R2CA02#	
		1.3pF	±0.05pF	GRM0224C1C1R3WA02#		
			±0.1pF	GRM0224C1C1R3BA02#		
			±0.25pF	GRM0224C1C1R3CA02#		
		1.4pF	±0.05pF	GRM0224C1C1R4WA02#		
			±0.1pF	GRM0224C1C1R4BA02#		
			±0.25pF	GRM0224C1C1R4CA02#		
		1.5pF	±0.05pF	GRM0224C1C1R5WA02#		
			±0.1pF	GRM0224C1C1R5BA02#		
			±0.25pF	GRM0224C1C1R5CA02#		
		1.6pF	±0.05pF	GRM0224C1C1R6WA02#		
			±0.1pF	GRM0224C1C1R6BA02#		
±0.25pF	GRM0224C1C1R6CA02#					
1.7pF	±0.05pF	GRM0224C1C1R7WA02#				
	±0.1pF	GRM0224C1C1R7BA02#				
	±0.25pF	GRM0224C1C1R7CA02#				

品名 # 表示包装规格代码。

GRM 系列
GJM 系列
GMA 系列
GMD 系列
GQM 系列
GRJ 系列
GR3 系列
KRM 系列
KRP 系列
LLA 系列
LLL 系列
LLM 系列
LLR 系列
警告/注意事项

GRM 系列温度补偿型品名列表

(→ ■ 0.4×0.2mm)

T 最大值	额定 电压	温度特 性代号	静电容量	公差	品名	
0.22mm	16Vdc	CK	1.8pF	±0.05pF	GRM0224C1C1R8WA02#	
				±0.1pF	GRM0224C1C1R8BA02#	
				±0.25pF	GRM0224C1C1R8CA02#	
			1.9pF	±0.05pF	GRM0224C1C1R9WA02#	
				±0.1pF	GRM0224C1C1R9BA02#	
				±0.25pF	GRM0224C1C1R9CA02#	
			2.0pF	±0.05pF	GRM0224C1C2R0WA02#	
				±0.1pF	GRM0224C1C2R0BA02#	
				±0.25pF	GRM0224C1C2R0CA02#	
			CJ	2.1pF	±0.05pF	GRM0223C1C2R1WA02#
					±0.1pF	GRM0223C1C2R1BA02#
					±0.25pF	GRM0223C1C2R1CA02#
				2.2pF	±0.05pF	GRM0223C1C2R2WA02#
					±0.1pF	GRM0223C1C2R2BA02#
					±0.25pF	GRM0223C1C2R2CA02#
		2.3pF		±0.05pF	GRM0223C1C2R3WA02#	
				±0.1pF	GRM0223C1C2R3BA02#	
				±0.25pF	GRM0223C1C2R3CA02#	
		2.4pF		±0.05pF	GRM0223C1C2R4WA02#	
				±0.1pF	GRM0223C1C2R4BA02#	
				±0.25pF	GRM0223C1C2R4CA02#	
		2.5pF		±0.05pF	GRM0223C1C2R5WA02#	
				±0.1pF	GRM0223C1C2R5BA02#	
				±0.25pF	GRM0223C1C2R5CA02#	
		2.6pF	±0.05pF	GRM0223C1C2R6WA02#		
			±0.1pF	GRM0223C1C2R6BA02#		
			±0.25pF	GRM0223C1C2R6CA02#		
		2.7pF	±0.05pF	GRM0223C1C2R7WA02#		
			±0.1pF	GRM0223C1C2R7BA02#		
			±0.25pF	GRM0223C1C2R7CA02#		
		2.8pF	±0.05pF	GRM0223C1C2R8WA02#		
			±0.1pF	GRM0223C1C2R8BA02#		
			±0.25pF	GRM0223C1C2R8CA02#		
		2.9pF	±0.05pF	GRM0223C1C2R9WA02#		
			±0.1pF	GRM0223C1C2R9BA02#		
			±0.25pF	GRM0223C1C2R9CA02#		
		3.0pF	±0.05pF	GRM0223C1C3R0WA02#		
			±0.1pF	GRM0223C1C3R0BA02#		
			±0.25pF	GRM0223C1C3R0CA02#		
		3.1pF	±0.05pF	GRM0223C1C3R1WA02#		
			±0.1pF	GRM0223C1C3R1BA02#		
			±0.25pF	GRM0223C1C3R1CA02#		
		3.2pF	±0.05pF	GRM0223C1C3R2WA02#		
			±0.1pF	GRM0223C1C3R2BA02#		
			±0.25pF	GRM0223C1C3R2CA02#		
3.3pF	±0.05pF	GRM0223C1C3R3WA02#				
	±0.1pF	GRM0223C1C3R3BA02#				
	±0.25pF	GRM0223C1C3R3CA02#				
3.4pF	±0.05pF	GRM0223C1C3R4WA02#				
	±0.1pF	GRM0223C1C3R4BA02#				
	±0.25pF	GRM0223C1C3R4CA02#				
3.5pF	±0.05pF	GRM0223C1C3R5WA02#				
	±0.1pF	GRM0223C1C3R5BA02#				
	±0.25pF	GRM0223C1C3R5CA02#				

T 最大值	额定 电压	温度特 性代号	静电容量	公差	品名	
0.22mm	16Vdc	CJ	3.6pF	±0.05pF	GRM0223C1C3R6WA02#	
				±0.1pF	GRM0223C1C3R6BA02#	
				±0.25pF	GRM0223C1C3R6CA02#	
			3.7pF	±0.05pF	GRM0223C1C3R7WA02#	
				±0.1pF	GRM0223C1C3R7BA02#	
				±0.25pF	GRM0223C1C3R7CA02#	
			3.8pF	±0.05pF	GRM0223C1C3R8WA02#	
				±0.1pF	GRM0223C1C3R8BA02#	
				±0.25pF	GRM0223C1C3R8CA02#	
			3.9pF	±0.05pF	GRM0223C1C3R9WA02#	
				±0.1pF	GRM0223C1C3R9BA02#	
				±0.25pF	GRM0223C1C3R9CA02#	
			CH	0.20pF	±0.05pF	GRM0222C1CR20WA02#
					±0.1pF	GRM0222C1CR20BA02#
					±0.25pF	GRM0222C1CR20CA02#
		0.30pF		±0.05pF	GRM0222C1CR30WA02#	
				±0.1pF	GRM0222C1CR30BA02#	
				±0.25pF	GRM0222C1CR30CA02#	
		0.40pF		±0.05pF	GRM0222C1CR40WA02#	
				±0.1pF	GRM0222C1CR40BA02#	
				±0.25pF	GRM0222C1CR40CA02#	
		0.50pF		±0.05pF	GRM0222C1CR50WA02#	
				±0.1pF	GRM0222C1CR50BA02#	
				±0.25pF	GRM0222C1CR50CA02#	
		0.60pF		±0.05pF	GRM0222C1CR60WA02#	
				±0.1pF	GRM0222C1CR60BA02#	
				±0.25pF	GRM0222C1CR60CA02#	
		0.70pF	±0.05pF	GRM0222C1CR70WA02#		
			±0.1pF	GRM0222C1CR70BA02#		
			±0.25pF	GRM0222C1CR70CA02#		
		0.80pF	±0.05pF	GRM0222C1CR80WA02#		
			±0.1pF	GRM0222C1CR80BA02#		
			±0.25pF	GRM0222C1CR80CA02#		
		0.90pF	±0.05pF	GRM0222C1CR90WA02#		
			±0.1pF	GRM0222C1CR90BA02#		
			±0.25pF	GRM0222C1CR90CA02#		
		1.0pF	±0.05pF	GRM0222C1C1R0WA02#		
			±0.1pF	GRM0222C1C1R0BA02#		
			±0.25pF	GRM0222C1C1R0CA02#		
		1.1pF	±0.05pF	GRM0222C1C1R1WA02#		
			±0.1pF	GRM0222C1C1R1BA02#		
			±0.25pF	GRM0222C1C1R1CA02#		
		1.2pF	±0.05pF	GRM0222C1C1R2WA02#		
			±0.1pF	GRM0222C1C1R2BA02#		
			±0.25pF	GRM0222C1C1R2CA02#		
1.3pF	±0.05pF	GRM0222C1C1R3WA02#				
	±0.1pF	GRM0222C1C1R3BA02#				
	±0.25pF	GRM0222C1C1R3CA02#				
1.4pF	±0.05pF	GRM0222C1C1R4WA02#				
	±0.1pF	GRM0222C1C1R4BA02#				
	±0.25pF	GRM0222C1C1R4CA02#				
1.5pF	±0.05pF	GRM0222C1C1R5WA02#				
	±0.1pF	GRM0222C1C1R5BA02#				
	±0.25pF	GRM0222C1C1R5CA02#				
1.6pF	±0.05pF	GRM0222C1C1R6WA02#				
	±0.1pF	GRM0222C1C1R6BA02#				
	±0.25pF	GRM0222C1C1R6CA02#				
1.7pF	±0.05pF	GRM0222C1C1R7WA02#				
	±0.1pF	GRM0222C1C1R7BA02#				
	±0.25pF	GRM0222C1C1R7CA02#				
1.8pF	±0.05pF	GRM0222C1C1R8WA02#				
	±0.1pF	GRM0222C1C1R8BA02#				
	±0.25pF	GRM0222C1C1R8CA02#				

品名 # 表示包装规格代码。

- GRM 系列
- GJM 系列
- GMA 系列
- GMD 系列
- GQM 系列
- GRJ 系列
- GR3 系列
- KRM 系列
- KR3 系列
- LJA 系列
- LLL 系列
- LJM 系列
- LLR 系列
- 警告 / 注意事项

GRM 系列温度补偿型品名列表

(→ ■ 0.4×0.2mm)

T 最大值	额定 电压	温度特 性代号	静电容量	公差	品名
0.22mm	16Vdc	CH	1.8pF	±0.25pF	GRM0222C1C1R8CA02#
				±0.05pF	GRM0222C1C1R9WA02#
					±0.1pF
			±0.25pF		GRM0222C1C1R9CA02#
			2.0pF	±0.05pF	GRM0222C1C2R0WA02#
				±0.1pF	GRM0222C1C2R0BA02#
				±0.25pF	GRM0222C1C2R0CA02#
			2.1pF	±0.05pF	GRM0222C1C2R1WA02#
				±0.1pF	GRM0222C1C2R1BA02#
				±0.25pF	GRM0222C1C2R1CA02#
			2.2pF	±0.05pF	GRM0222C1C2R2WA02#
				±0.1pF	GRM0222C1C2R2BA02#
				±0.25pF	GRM0222C1C2R2CA02#
			2.3pF	±0.05pF	GRM0222C1C2R3WA02#
				±0.1pF	GRM0222C1C2R3BA02#
				±0.25pF	GRM0222C1C2R3CA02#
			2.4pF	±0.05pF	GRM0222C1C2R4WA02#
				±0.1pF	GRM0222C1C2R4BA02#
				±0.25pF	GRM0222C1C2R4CA02#
			2.5pF	±0.05pF	GRM0222C1C2R5WA02#
				±0.1pF	GRM0222C1C2R5BA02#
				±0.25pF	GRM0222C1C2R5CA02#
			2.6pF	±0.05pF	GRM0222C1C2R6WA02#
				±0.1pF	GRM0222C1C2R6BA02#
				±0.25pF	GRM0222C1C2R6CA02#
			2.7pF	±0.05pF	GRM0222C1C2R7WA02#
				±0.1pF	GRM0222C1C2R7BA02#
				±0.25pF	GRM0222C1C2R7CA02#
			2.8pF	±0.05pF	GRM0222C1C2R8WA02#
				±0.1pF	GRM0222C1C2R8BA02#
				±0.25pF	GRM0222C1C2R8CA02#
			2.9pF	±0.05pF	GRM0222C1C2R9WA02#
				±0.1pF	GRM0222C1C2R9BA02#
				±0.25pF	GRM0222C1C2R9CA02#
			3.0pF	±0.05pF	GRM0222C1C3R0WA02#
				±0.1pF	GRM0222C1C3R0BA02#
				±0.25pF	GRM0222C1C3R0CA02#
			3.1pF	±0.05pF	GRM0222C1C3R1WA02#
				±0.1pF	GRM0222C1C3R1BA02#
				±0.25pF	GRM0222C1C3R1CA02#
			3.2pF	±0.05pF	GRM0222C1C3R2WA02#
				±0.1pF	GRM0222C1C3R2BA02#
				±0.25pF	GRM0222C1C3R2CA02#
			3.3pF	±0.05pF	GRM0222C1C3R3WA02#
				±0.1pF	GRM0222C1C3R3BA02#
				±0.25pF	GRM0222C1C3R3CA02#
			3.4pF	±0.05pF	GRM0222C1C3R4WA02#
				±0.1pF	GRM0222C1C3R4BA02#
				±0.25pF	GRM0222C1C3R4CA02#
			3.5pF	±0.05pF	GRM0222C1C3R5WA02#
				±0.1pF	GRM0222C1C3R5BA02#
				±0.25pF	GRM0222C1C3R5CA02#
			3.6pF	±0.05pF	GRM0222C1C3R6WA02#
				±0.1pF	GRM0222C1C3R6BA02#

T 最大值	额定 电压	温度特 性代号	静电容量	公差	品名
0.22mm	16Vdc	CH	3.6pF	±0.25pF	GRM0222C1C3R6CA02#
				±0.05pF	GRM0222C1C3R7WA02#
					±0.1pF
			±0.25pF		GRM0222C1C3R7CA02#
			3.8pF	±0.05pF	GRM0222C1C3R8WA02#
				±0.1pF	GRM0222C1C3R8BA02#
				±0.25pF	GRM0222C1C3R8CA02#
			3.9pF	±0.05pF	GRM0222C1C3R9WA02#
				±0.1pF	GRM0222C1C3R9BA02#
				±0.25pF	GRM0222C1C3R9CA02#
			4.0pF	±0.05pF	GRM0222C1C4R0WA02#
				±0.1pF	GRM0222C1C4R0BA02#
				±0.25pF	GRM0222C1C4R0CA02#
			4.1pF	±0.05pF	GRM0222C1C4R1WA02#
				±0.1pF	GRM0222C1C4R1BA02#
				±0.25pF	GRM0222C1C4R1CA02#
			4.2pF	±0.05pF	GRM0222C1C4R2WA02#
				±0.1pF	GRM0222C1C4R2BA02#
				±0.25pF	GRM0222C1C4R2CA02#
			4.3pF	±0.05pF	GRM0222C1C4R3WA02#
				±0.1pF	GRM0222C1C4R3BA02#
				±0.25pF	GRM0222C1C4R3CA02#
			4.4pF	±0.05pF	GRM0222C1C4R4WA02#
				±0.1pF	GRM0222C1C4R4BA02#
				±0.25pF	GRM0222C1C4R4CA02#
			4.5pF	±0.05pF	GRM0222C1C4R5WA02#
				±0.1pF	GRM0222C1C4R5BA02#
				±0.25pF	GRM0222C1C4R5CA02#
			4.6pF	±0.05pF	GRM0222C1C4R6WA02#
				±0.1pF	GRM0222C1C4R6BA02#
				±0.25pF	GRM0222C1C4R6CA02#
			4.7pF	±0.05pF	GRM0222C1C4R7WA02#
				±0.1pF	GRM0222C1C4R7BA02#
				±0.25pF	GRM0222C1C4R7CA02#
			4.8pF	±0.05pF	GRM0222C1C4R8WA02#
				±0.1pF	GRM0222C1C4R8BA02#
				±0.25pF	GRM0222C1C4R8CA02#
			4.9pF	±0.05pF	GRM0222C1C4R9WA02#
				±0.1pF	GRM0222C1C4R9BA02#
				±0.25pF	GRM0222C1C4R9CA02#
			5.0pF	±0.05pF	GRM0222C1C5R0WA02#
				±0.1pF	GRM0222C1C5R0BA02#
				±0.25pF	GRM0222C1C5R0CA02#
			5.1pF	±0.05pF	GRM0222C1C5R1WA02#
				±0.1pF	GRM0222C1C5R1BA02#
				±0.25pF	GRM0222C1C5R1CA02#
			5.2pF	±0.05pF	GRM0222C1C5R2WA02#
				±0.1pF	GRM0222C1C5R2BA02#
				±0.25pF	GRM0222C1C5R2CA02#
			5.3pF	±0.05pF	GRM0222C1C5R3WA02#
				±0.1pF	GRM0222C1C5R3BA02#
				±0.25pF	GRM0222C1C5R3CA02#

品名 # 表示包装规格代码。

GRM 系列
GJM 系列
GMA 系列
GMD 系列
GQM 系列
GRJ 系列
GR3 系列
KRM 系列
KR3 系列
LLA 系列
LLL 系列
LLM 系列
LLR 系列
警告/注意事项

GRM 系列温度补偿型品名列表

(→ ■ 0.4×0.2mm)

T 最大值	额定 电压	温度特 性代号	静电容量	公差	品名
0.22mm	16Vdc	CH	5.3pF	±0.5pF	GRM0222C1C5R3DA02#
				±0.05pF	GRM0222C1C5R4WA02#
			5.4pF	±0.1pF	GRM0222C1C5R4BA02#
				±0.25pF	GRM0222C1C5R4CA02#
			5.5pF	±0.5pF	GRM0222C1C5R4DA02#
				±0.05pF	GRM0222C1C5R5WA02#
				±0.1pF	GRM0222C1C5R5BA02#
			5.6pF	±0.25pF	GRM0222C1C5R5CA02#
				±0.5pF	GRM0222C1C5R5DA02#
				±0.05pF	GRM0222C1C5R6WA02#
			5.7pF	±0.1pF	GRM0222C1C5R6BA02#
				±0.25pF	GRM0222C1C5R6CA02#
				±0.5pF	GRM0222C1C5R6DA02#
			5.8pF	±0.05pF	GRM0222C1C5R7WA02#
				±0.1pF	GRM0222C1C5R7BA02#
				±0.25pF	GRM0222C1C5R7CA02#
			5.9pF	±0.5pF	GRM0222C1C5R7DA02#
				±0.05pF	GRM0222C1C5R8WA02#
				±0.1pF	GRM0222C1C5R8BA02#
			6.0pF	±0.25pF	GRM0222C1C5R8CA02#
				±0.5pF	GRM0222C1C5R8DA02#
				±0.05pF	GRM0222C1C5R9WA02#
			6.1pF	±0.1pF	GRM0222C1C5R9BA02#
				±0.25pF	GRM0222C1C5R9CA02#
				±0.5pF	GRM0222C1C5R9DA02#
			6.2pF	±0.05pF	GRM0222C1C6R0WA02#
				±0.1pF	GRM0222C1C6R0BA02#
				±0.25pF	GRM0222C1C6R0CA02#
			6.3pF	±0.5pF	GRM0222C1C6R0DA02#
				±0.05pF	GRM0222C1C6R1WA02#
				±0.1pF	GRM0222C1C6R1BA02#
			6.4pF	±0.25pF	GRM0222C1C6R1CA02#
				±0.5pF	GRM0222C1C6R1DA02#
				±0.05pF	GRM0222C1C6R2WA02#
			6.5pF	±0.1pF	GRM0222C1C6R2BA02#
				±0.25pF	GRM0222C1C6R2CA02#
				±0.5pF	GRM0222C1C6R2DA02#
			6.6pF	±0.05pF	GRM0222C1C6R3WA02#
				±0.1pF	GRM0222C1C6R3BA02#
				±0.25pF	GRM0222C1C6R3CA02#
			6.7pF	±0.5pF	GRM0222C1C6R3DA02#
				±0.05pF	GRM0222C1C6R4WA02#
±0.1pF	GRM0222C1C6R4BA02#				
6.8pF	±0.25pF	GRM0222C1C6R4CA02#			
	±0.5pF	GRM0222C1C6R4DA02#			
	±0.05pF	GRM0222C1C6R5WA02#			
6.9pF	±0.1pF	GRM0222C1C6R5BA02#			
	±0.25pF	GRM0222C1C6R5CA02#			
	±0.5pF	GRM0222C1C6R5DA02#			
7.0pF	±0.05pF	GRM0222C1C6R6WA02#			
	±0.1pF	GRM0222C1C6R6BA02#			
	±0.25pF	GRM0222C1C6R6CA02#			
7.1pF	±0.5pF	GRM0222C1C6R6DA02#			
	±0.05pF	GRM0222C1C6R7WA02#			
	±0.1pF	GRM0222C1C6R7BA02#			
7.2pF	±0.25pF	GRM0222C1C6R7CA02#			
	±0.5pF	GRM0222C1C6R7DA02#			
	±0.05pF	GRM0222C1C6R8WA02#			
7.3pF	±0.1pF	GRM0222C1C6R8BA02#			
	±0.25pF	GRM0222C1C6R8CA02#			
	±0.5pF	GRM0222C1C6R8DA02#			
7.4pF	±0.05pF	GRM0222C1C6R9WA02#			
	±0.1pF	GRM0222C1C6R9BA02#			
	±0.25pF	GRM0222C1C6R9CA02#			
7.5pF	±0.5pF	GRM0222C1C6R9DA02#			
	±0.05pF	GRM0222C1C7R0WA02#			
	±0.1pF	GRM0222C1C7R0BA02#			
7.6pF	±0.25pF	GRM0222C1C7R0CA02#			
	±0.5pF	GRM0222C1C7R0DA02#			
	±0.05pF	GRM0222C1C7R1WA02#			
7.7pF	±0.1pF	GRM0222C1C7R1BA02#			
	±0.25pF	GRM0222C1C7R1CA02#			
	±0.5pF	GRM0222C1C7R1DA02#			
7.8pF	±0.05pF	GRM0222C1C7R2WA02#			
	±0.1pF	GRM0222C1C7R2BA02#			
	±0.25pF	GRM0222C1C7R2CA02#			
7.9pF	±0.5pF	GRM0222C1C7R2DA02#			
	±0.05pF	GRM0222C1C7R3WA02#			
	±0.1pF	GRM0222C1C7R3BA02#			
8.0pF	±0.25pF	GRM0222C1C7R3CA02#			
	±0.5pF	GRM0222C1C7R3DA02#			
	±0.05pF	GRM0222C1C7R4WA02#			
8.1pF	±0.1pF	GRM0222C1C7R4BA02#			
	±0.25pF	GRM0222C1C7R4CA02#			
	±0.5pF	GRM0222C1C7R4DA02#			
8.2pF	±0.05pF	GRM0222C1C7R5WA02#			
	±0.1pF	GRM0222C1C7R5BA02#			
	±0.25pF	GRM0222C1C7R5CA02#			
8.3pF	±0.5pF	GRM0222C1C7R5DA02#			
	±0.05pF	GRM0222C1C7R6WA02#			
	±0.1pF	GRM0222C1C7R6BA02#			
8.4pF	±0.25pF	GRM0222C1C7R6CA02#			
	±0.5pF	GRM0222C1C7R6DA02#			
	±0.05pF	GRM0222C1C7R7WA02#			
8.5pF	±0.1pF	GRM0222C1C7R7BA02#			
	±0.25pF	GRM0222C1C7R7CA02#			
	±0.5pF	GRM0222C1C7R7DA02#			
8.6pF	±0.05pF	GRM0222C1C7R8WA02#			
	±0.1pF	GRM0222C1C7R8BA02#			
	±0.25pF	GRM0222C1C7R8CA02#			
8.7pF	±0.5pF	GRM0222C1C7R8DA02#			
	±0.05pF	GRM0222C1C7R9WA02#			
	±0.1pF	GRM0222C1C7R9BA02#			
8.8pF	±0.25pF	GRM0222C1C7R9CA02#			
	±0.5pF	GRM0222C1C7R9DA02#			
	±0.05pF	GRM0222C1C8R0WA02#			
8.9pF	±0.1pF	GRM0222C1C8R0BA02#			
	±0.25pF	GRM0222C1C8R0CA02#			
	±0.5pF	GRM0222C1C8R0DA02#			

T 最大值	额定 电压	温度特 性代号	静电容量	公差	品名
0.22mm	16Vdc	CH	6.7pF	±0.1pF	GRM0222C1C6R7BA02#
				±0.25pF	GRM0222C1C6R7CA02#
			6.8pF	±0.5pF	GRM0222C1C6R7DA02#
				±0.05pF	GRM0222C1C6R8WA02#
			6.9pF	±0.1pF	GRM0222C1C6R8BA02#
				±0.25pF	GRM0222C1C6R8CA02#
				±0.5pF	GRM0222C1C6R8DA02#
			7.0pF	±0.05pF	GRM0222C1C6R9WA02#
				±0.1pF	GRM0222C1C6R9BA02#
				±0.25pF	GRM0222C1C6R9CA02#
			7.1pF	±0.5pF	GRM0222C1C6R9DA02#
				±0.05pF	GRM0222C1C7R0WA02#
				±0.1pF	GRM0222C1C7R0BA02#
			7.2pF	±0.25pF	GRM0222C1C7R0CA02#
				±0.5pF	GRM0222C1C7R0DA02#
				±0.05pF	GRM0222C1C7R1WA02#
			7.3pF	±0.1pF	GRM0222C1C7R1BA02#
				±0.25pF	GRM0222C1C7R1CA02#
				±0.5pF	GRM0222C1C7R1DA02#
			7.4pF	±0.05pF	GRM0222C1C7R2WA02#
				±0.1pF	GRM0222C1C7R2BA02#
				±0.25pF	GRM0222C1C7R2CA02#
			7.5pF	±0.5pF	GRM0222C1C7R2DA02#
				±0.05pF	GRM0222C1C7R3WA02#
				±0.1pF	GRM0222C1C7R3BA02#
			7.6pF	±0.25pF	GRM0222C1C7R3CA02#
				±0.5pF	GRM0222C1C7R3DA02#
				±0.05pF	GRM0222C1C7R4WA02#
			7.7pF	±0.1pF	GRM0222C1C7R4BA02#
				±0.25pF	GRM0222C1C7R4CA02#
				±0.5pF	GRM0222C1C7R4DA02#
			7.8pF	±0.05pF	GRM0222C1C7R5WA02#
				±0.1pF	GRM0222C1C7R5BA02#
				±0.25pF	GRM0222C1C7R5CA02#
			7.9pF	±0.5pF	GRM0222C1C7R5DA02#
				±0.05pF	GRM0222C1C7R6WA02#
				±0.1pF	GRM0222C1C7R6BA02#
			8.0pF	±0.25pF	GRM0222C1C7R6CA02#
				±0.5pF	GRM0222C1C7R6DA02#
				±0.05pF	GRM0222C1C7R7WA02#
			8.1pF	±0.1pF	GRM0222C1C7R7BA02#
				±0.25pF	GRM0222C1C7R7CA02#
±0.5pF	GRM0222C1C7R7DA02#				
8.2pF	±0.05pF	GRM0222C1C7R8WA02#			
	±0.1pF	GRM0222C1C7R8BA02#			
	±0.25pF	GRM0222C1C7R8CA02#			
8.3pF	±0.5pF	GRM0222C1C7R8DA02#			
	±0.05pF	GRM0222C1C7R9WA02#			
	±0.1pF	GRM0222C1C7R9BA02#			
8.4pF	±0.25pF	GRM0222C1C7R9CA02#			
	±0.5pF	GRM0222C1C7R9DA02#			
	±0.05pF	GRM0222C1C8R0WA02#			
8.5pF	±0.1pF	GRM0222C1C8R0BA02#			
	±0.25pF	GRM0222C1C8R0CA02#			
	±0.5pF	GRM0222C1C8R0DA02#			

品名 # 表示包装规格代码。

- GRM 系列
- GJM 系列
- GMA 系列
- GMD 系列
- GQM 系列
- GRJ 系列
- GR3 系列
- KRM 系列
- KR3 系列
- LJA 系列
- LLL 系列
- LLM 系列
- LLR 系列
- 警告 / 注意事项

GRM 系列温度补偿型品名列表

(→ ■ 0.4×0.2mm)

T 最大值	额定 电压	温度特 性代号	静电容量	公差	品名
0.22mm	16Vdc	CH	8.0pF	±0.5pF	GRM0222C1C8R0DA02#
				±0.05pF	GRM0222C1C8R1WA02#
					±0.1pF
			±0.25pF		GRM0222C1C8R1CA02#
			8.1pF	±0.5pF	GRM0222C1C8R1DA02#
				±0.05pF	GRM0222C1C8R2WA02#
					±0.1pF
			±0.25pF		GRM0222C1C8R2CA02#
			8.2pF	±0.5pF	GRM0222C1C8R2DA02#
				±0.05pF	GRM0222C1C8R3WA02#
					±0.1pF
			±0.25pF		GRM0222C1C8R3CA02#
			8.3pF	±0.5pF	GRM0222C1C8R3DA02#
				±0.05pF	GRM0222C1C8R4WA02#
					±0.1pF
			±0.25pF		GRM0222C1C8R4CA02#
			8.4pF	±0.5pF	GRM0222C1C8R4DA02#
				±0.05pF	GRM0222C1C8R5WA02#
					±0.1pF
			±0.25pF		GRM0222C1C8R5CA02#
			8.5pF	±0.5pF	GRM0222C1C8R5DA02#
				±0.05pF	GRM0222C1C8R6WA02#
					±0.1pF
			±0.25pF		GRM0222C1C8R6CA02#
			8.6pF	±0.5pF	GRM0222C1C8R6DA02#
				±0.05pF	GRM0222C1C8R7WA02#
					±0.1pF
			±0.25pF		GRM0222C1C8R7CA02#
			8.7pF	±0.5pF	GRM0222C1C8R7DA02#
				±0.05pF	GRM0222C1C8R8WA02#
					±0.1pF
			±0.25pF		GRM0222C1C8R8CA02#
			8.8pF	±0.5pF	GRM0222C1C8R8DA02#
				±0.05pF	GRM0222C1C8R9WA02#
					±0.1pF
			±0.25pF		GRM0222C1C8R9CA02#
			8.9pF	±0.5pF	GRM0222C1C8R9DA02#
				±0.05pF	GRM0222C1C9R0WA02#
					±0.1pF
			±0.25pF		GRM0222C1C9R0CA02#
			9.0pF	±0.5pF	GRM0222C1C9R0DA02#
				±0.05pF	GRM0222C1C9R1WA02#
					±0.1pF
			±0.25pF		GRM0222C1C9R1CA02#
			9.1pF	±0.5pF	GRM0222C1C9R1DA02#
				±0.05pF	GRM0222C1C9R2WA02#
					±0.1pF
			±0.25pF		GRM0222C1C9R2CA02#
9.2pF	±0.5pF	GRM0222C1C9R2DA02#			
	±0.05pF	GRM0222C1C9R3WA02#			
		±0.1pF	GRM0222C1C9R3BA02#		
±0.25pF		GRM0222C1C9R3CA02#			
9.3pF	±0.5pF	GRM0222C1C9R3DA02#			
	±0.05pF	GRM0222C1C9R4WA02#			

T 最大值	额定 电压	温度特 性代号	静电容量	公差	品名
0.22mm	16Vdc	CH	9.4pF	±0.1pF	GRM0222C1C9R4BA02#
				±0.25pF	GRM0222C1C9R4CA02#
				±0.5pF	GRM0222C1C9R4DA02#
			9.5pF	±0.05pF	GRM0222C1C9R5WA02#
				±0.1pF	GRM0222C1C9R5BA02#
				±0.25pF	GRM0222C1C9R5CA02#
			9.6pF	±0.5pF	GRM0222C1C9R5DA02#
				±0.05pF	GRM0222C1C9R6WA02#
					±0.1pF
			±0.25pF		GRM0222C1C9R6CA02#
			9.7pF	±0.5pF	GRM0222C1C9R6DA02#
				±0.05pF	GRM0222C1C9R7WA02#
					±0.1pF
			±0.25pF		GRM0222C1C9R7CA02#
			9.8pF	±0.5pF	GRM0222C1C9R7DA02#
				±0.05pF	GRM0222C1C9R8WA02#
					±0.1pF
			±0.25pF		GRM0222C1C9R8CA02#
			9.9pF	±0.5pF	GRM0222C1C9R8DA02#
				±0.05pF	GRM0222C1C9R9WA02#
					±0.1pF
			10pF		±0.25pF
				±0.5pF	GRM0222C1C9R9DA02#
				±2%	GRM0222C1C100GA02#
			±5%	GRM0222C1C100JA02#	
			10.5pF	±2%	GRM0222C1C10EGA02#
				±2%	GRM0222C1C110GA02#
					±5%
			11pF		±2%
				±5%	GRM0222C1C120JA02#
				12pF	±2%
			±2%		GRM0222C1C130GA02#
					±5%
				13pF	±2%
			±5%		GRM0222C1C140JA02#
			14pF		±2%
				±5%	GRM0222C1C150JA02#
				15pF	±2%
			±5%		GRM0222C1C160JA02#
			16pF		±2%
				±5%	GRM0222C1C170JA02#
				17pF	±2%
			±5%		GRM0222C1C180JA02#
			18pF		±2%
				±5%	GRM0222C1C190JA02#
				19pF	±2%
			±5%		GRM0222C1C200JA02#
			20pF		±2%
±5%	GRM0222C1C210JA02#				
21pF	±2%	GRM0222C1C220GA02#			
	±5%	GRM0222C1C220JA02#			
	22pF	±2%	GRM0222C1C240GA02#		
±5%		GRM0222C1C240JA02#			
24pF		±2%	GRM0222C1C270GA02#		

品名 # 表示包装规格代码。

GRM 系列
GJM 系列
GMA 系列
GMD 系列
GQM 系列
GRJ 系列
GR3 系列
KRM 系列
KR3 系列
LLA 系列
LLL 系列
LLM 系列
LLR 系列
警告/注意事项

GRM 系列温度补偿型品名列表

(→ ■ 0.4×0.2mm)

T 最大值	额定 电压	温度特 性代号	静电容量	公差	品名		
0.22mm	16Vdc	CH	27pF	±5%	GRM0222C1C270JA02#		
				±2%	GRM0222C1C300GA02#		
			30pF	±5%	GRM0222C1C300JA02#		
				±2%	GRM0222C1C330GA02#		
			33pF	±5%	GRM0222C1C330JA02#		
				±2%	GRM0222C1C360GA02#		
			36pF	±5%	GRM0222C1C360JA02#		
				±2%	GRM0222C1C390GA02#		
			39pF	±5%	GRM0222C1C390JA02#		
				±2%	GRM0222C1C430GA02#		
			43pF	±5%	GRM0222C1C430JA02#		
				±2%	GRM0222C1C470GA02#		
			47pF	±5%	GRM0222C1C470JA02#		
				±2%	GRM0222C1C510GA02#		
			51pF	±5%	GRM0222C1C510JA02#		
				±2%	GRM0222C1C560GA02#		
			56pF	±5%	GRM0222C1C560JA02#		
				±2%	GRM0222C1C620GA02#		
			62pF	±5%	GRM0222C1C620JA02#		
				±2%	GRM0222C1C680GA02#		
			68pF	±5%	GRM0222C1C680JA02#		
				±2%	GRM0222C1C750GA02#		
			75pF	±5%	GRM0222C1C750JA02#		
				±2%	GRM0222C1C820GA02#		
			82pF	±5%	GRM0222C1C820JA02#		
				±2%	GRM0222C1C910GA02#		
			91pF	±5%	GRM0222C1C910JA02#		
				±2%	GRM0222C1C101GA02#		
			100pF	±5%	GRM0222C1C101JA02#		
				10Vdc	COG	56pF	±2%
			±5%				GRM0225C1A560JD05#
			68pF			±2%	GRM0225C1A680GD05#
						±5%	GRM0225C1A680JD05#
			82pF			±2%	GRM0225C1A820GD05#
						±5%	GRM0225C1A820JD05#
			100pF	±2%	GRM0225C1A101GD05#		
±5%	GRM0225C1A101JD05#						
10Vdc	CH	56pF	±2%	GRM0222C1A560GD05#			
			±5%	GRM0222C1A560JD05#			
		68pF	±2%	GRM0222C1A680GD05#			
			±5%	GRM0222C1A680JD05#			
		82pF	±2%	GRM0222C1A820GD05#			
			±5%	GRM0222C1A820JD05#			
		100pF	±2%	GRM0222C1A101GD05#			
			±5%	GRM0222C1A101JD05#			

■ 0.6×0.3mm 超小型

T 最大值	额定 电压	温度特 性代号	静电容量	公差	品名
0.33mm	100Vdc	COG	0.10pF	±0.05pF	GRM0335C2AR10WA01#
				±0.1pF	GRM0335C2AR20WA01#
			0.20pF	±0.05pF	GRM0335C2AR20BA01#
				±0.1pF	GRM0335C2AR30WA01#

T 最大值	额定 电压	温度特 性代号	静电容量	公差	品名
0.33mm	100Vdc	COG	0.30pF	±0.1pF	GRM0335C2AR30BA01#
				±0.05pF	GRM0335C2AR40WA01#
			0.40pF	±0.1pF	GRM0335C2AR40BA01#
				±0.05pF	GRM0335C2AR50WA01#
			0.50pF	±0.1pF	GRM0335C2AR50BA01#
				±0.05pF	GRM0335C2AR60WA01#
			0.60pF	±0.1pF	GRM0335C2AR60BA01#
				±0.05pF	GRM0335C2AR70WA01#
			0.70pF	±0.1pF	GRM0335C2AR70BA01#
				±0.05pF	GRM0335C2AR80WA01#
			0.80pF	±0.1pF	GRM0335C2AR80BA01#
				±0.05pF	GRM0335C2AR90WA01#
			0.90pF	±0.1pF	GRM0335C2AR90BA01#
				±0.05pF	GRM0335C2A1R0WA01#
			1.0pF	±0.1pF	GRM0335C2A1R0BA01#
				±0.25pF	GRM0335C2A1R0CA01#
				±0.05pF	GRM0335C2A1R1WA01#
				±0.1pF	GRM0335C2A1R1BA01#
			1.1pF	±0.25pF	GRM0335C2A1R1CA01#
				±0.05pF	GRM0335C2A1R2WA01#
			1.2pF	±0.1pF	GRM0335C2A1R2BA01#
				±0.25pF	GRM0335C2A1R2CA01#
			1.3pF	±0.05pF	GRM0335C2A1R3WA01#
				±0.1pF	GRM0335C2A1R3BA01#
			1.4pF	±0.25pF	GRM0335C2A1R3CA01#
				±0.05pF	GRM0335C2A1R4WA01#
			1.5pF	±0.1pF	GRM0335C2A1R4BA01#
				±0.25pF	GRM0335C2A1R4CA01#
			1.6pF	±0.05pF	GRM0335C2A1R5WA01#
				±0.1pF	GRM0335C2A1R5BA01#
				±0.25pF	GRM0335C2A1R5CA01#
			1.7pF	±0.05pF	GRM0335C2A1R6WA01#
				±0.1pF	GRM0335C2A1R6BA01#
				±0.25pF	GRM0335C2A1R6CA01#
			1.8pF	±0.05pF	GRM0335C2A1R7WA01#
				±0.1pF	GRM0335C2A1R7BA01#
				±0.25pF	GRM0335C2A1R7CA01#
			1.9pF	±0.05pF	GRM0335C2A1R8WA01#
				±0.1pF	GRM0335C2A1R8BA01#
				±0.25pF	GRM0335C2A1R8CA01#
			2.0pF	±0.05pF	GRM0335C2A1R9WA01#
				±0.1pF	GRM0335C2A1R9BA01#
				±0.25pF	GRM0335C2A1R9CA01#
			2.1pF	±0.05pF	GRM0335C2A2R0WA01#
				±0.1pF	GRM0335C2A2R0BA01#
				±0.25pF	GRM0335C2A2R0CA01#
			2.2pF	±0.05pF	GRM0335C2A2R1WA01#
				±0.1pF	GRM0335C2A2R1BA01#
±0.25pF	GRM0335C2A2R1CA01#				
2.3pF	±0.05pF	GRM0335C2A2R2WA01#			
	±0.1pF	GRM0335C2A2R2BA01#			
	±0.25pF	GRM0335C2A2R2CA01#			
2.4pF	±0.05pF	GRM0335C2A2R3WA01#			
	±0.1pF	GRM0335C2A2R3BA01#			

品名 # 表示包装规格代码。

- GRM 系列
- GJM 系列
- GMA 系列
- GMD 系列
- GQM 系列
- GRJ 系列
- GR3 系列
- KRM 系列
- KR3 系列
- LJA 系列
- LLL 系列
- LLM 系列
- LLR 系列
- △警告 / 注意事项

GRM 系列温度补偿型品名列表

(→ ■ 0.6×0.3mm)

T 最大值	额定 电压	温度特 性代号	静电容量	公差	品名	
0.33mm	100Vdc	C0G	2.3pF	±0.25pF	GRM0335C2A2R3CA01#	
				±0.05pF	GRM0335C2A2R4WA01#	
					±0.1pF	GRM0335C2A2R4BA01#
			±0.25pF	GRM0335C2A2R4CA01#		
				2.5pF	±0.05pF	GRM0335C2A2R5WA01#
					±0.1pF	GRM0335C2A2R5BA01#
			±0.25pF		GRM0335C2A2R5CA01#	
			2.6pF	±0.05pF	GRM0335C2A2R6WA01#	
				±0.1pF	GRM0335C2A2R6BA01#	
				±0.25pF	GRM0335C2A2R6CA01#	
			2.7pF	±0.05pF	GRM0335C2A2R7WA01#	
				±0.1pF	GRM0335C2A2R7BA01#	
				±0.25pF	GRM0335C2A2R7CA01#	
			2.8pF	±0.05pF	GRM0335C2A2R8WA01#	
				±0.1pF	GRM0335C2A2R8BA01#	
				±0.25pF	GRM0335C2A2R8CA01#	
			2.9pF	±0.05pF	GRM0335C2A2R9WA01#	
				±0.1pF	GRM0335C2A2R9BA01#	
				±0.25pF	GRM0335C2A2R9CA01#	
			3.0pF	±0.05pF	GRM0335C2A3R0WA01#	
				±0.1pF	GRM0335C2A3R0BA01#	
				±0.25pF	GRM0335C2A3R0CA01#	
			3.1pF	±0.05pF	GRM0335C2A3R1WA01#	
				±0.1pF	GRM0335C2A3R1BA01#	
				±0.25pF	GRM0335C2A3R1CA01#	
			3.2pF	±0.05pF	GRM0335C2A3R2WA01#	
				±0.1pF	GRM0335C2A3R2BA01#	
				±0.25pF	GRM0335C2A3R2CA01#	
			3.3pF	±0.05pF	GRM0335C2A3R3WA01#	
				±0.1pF	GRM0335C2A3R3BA01#	
				±0.25pF	GRM0335C2A3R3CA01#	
			3.4pF	±0.05pF	GRM0335C2A3R4WA01#	
				±0.1pF	GRM0335C2A3R4BA01#	
				±0.25pF	GRM0335C2A3R4CA01#	
			3.5pF	±0.05pF	GRM0335C2A3R5WA01#	
				±0.1pF	GRM0335C2A3R5BA01#	
				±0.25pF	GRM0335C2A3R5CA01#	
			3.6pF	±0.05pF	GRM0335C2A3R6WA01#	
				±0.1pF	GRM0335C2A3R6BA01#	
				±0.25pF	GRM0335C2A3R6CA01#	
			3.7pF	±0.05pF	GRM0335C2A3R7WA01#	
				±0.1pF	GRM0335C2A3R7BA01#	
				±0.25pF	GRM0335C2A3R7CA01#	
			3.8pF	±0.05pF	GRM0335C2A3R8WA01#	
				±0.1pF	GRM0335C2A3R8BA01#	
				±0.25pF	GRM0335C2A3R8CA01#	
			3.9pF	±0.05pF	GRM0335C2A3R9WA01#	
				±0.1pF	GRM0335C2A3R9BA01#	
±0.25pF	GRM0335C2A3R9CA01#					
4.0pF	±0.05pF	GRM0335C2A4R0WA01#				
	±0.1pF	GRM0335C2A4R0BA01#				
	±0.25pF	GRM0335C2A4R0CA01#				
4.1pF	±0.05pF	GRM0335C2A4R1WA01#				
	±0.1pF	GRM0335C2A4R1BA01#				

T 最大值	额定 电压	温度特 性代号	静电容量	公差	品名	
0.33mm	100Vdc	C0G	4.1pF	±0.25pF	GRM0335C2A4R1CA01#	
				±0.05pF	GRM0335C2A4R2WA01#	
					±0.1pF	GRM0335C2A4R2BA01#
			±0.25pF	GRM0335C2A4R2CA01#		
				4.3pF	±0.05pF	GRM0335C2A4R3WA01#
					±0.1pF	GRM0335C2A4R3BA01#
			±0.25pF		GRM0335C2A4R3CA01#	
			4.4pF	±0.05pF	GRM0335C2A4R4WA01#	
				±0.1pF	GRM0335C2A4R4BA01#	
				±0.25pF	GRM0335C2A4R4CA01#	
			4.5pF	±0.05pF	GRM0335C2A4R5WA01#	
				±0.1pF	GRM0335C2A4R5BA01#	
				±0.25pF	GRM0335C2A4R5CA01#	
			4.6pF	±0.05pF	GRM0335C2A4R6WA01#	
				±0.1pF	GRM0335C2A4R6BA01#	
				±0.25pF	GRM0335C2A4R6CA01#	
			4.7pF	±0.05pF	GRM0335C2A4R7WA01#	
				±0.1pF	GRM0335C2A4R7BA01#	
				±0.25pF	GRM0335C2A4R7CA01#	
			4.8pF	±0.05pF	GRM0335C2A4R8WA01#	
				±0.1pF	GRM0335C2A4R8BA01#	
				±0.25pF	GRM0335C2A4R8CA01#	
			4.9pF	±0.05pF	GRM0335C2A4R9WA01#	
				±0.1pF	GRM0335C2A4R9BA01#	
				±0.25pF	GRM0335C2A4R9CA01#	
			5.0pF	±0.05pF	GRM0335C2A5R0WA01#	
				±0.1pF	GRM0335C2A5R0BA01#	
				±0.25pF	GRM0335C2A5R0CA01#	
			5.1pF	±0.05pF	GRM0335C2A5R1WA01#	
				±0.1pF	GRM0335C2A5R1BA01#	
				±0.25pF	GRM0335C2A5R1CA01#	
			5.2pF	±0.05pF	GRM0335C2A5R2WA01#	
				±0.1pF	GRM0335C2A5R2BA01#	
				±0.25pF	GRM0335C2A5R2CA01#	
			±0.5pF	±0.5pF	GRM0335C2A5R1DA01#	
				5.3pF	±0.05pF	GRM0335C2A5R3WA01#
					±0.1pF	GRM0335C2A5R3BA01#
			±0.25pF		GRM0335C2A5R3CA01#	
			±0.5pF	±0.5pF	GRM0335C2A5R3DA01#	
				5.4pF	±0.05pF	GRM0335C2A5R4WA01#
					±0.1pF	GRM0335C2A5R4BA01#
			±0.25pF		GRM0335C2A5R4CA01#	
			±0.5pF	±0.5pF	GRM0335C2A5R4DA01#	
				5.5pF	±0.05pF	GRM0335C2A5R5WA01#
					±0.1pF	GRM0335C2A5R5BA01#
			±0.25pF		GRM0335C2A5R5CA01#	
			±0.5pF	±0.5pF	GRM0335C2A5R5DA01#	
				5.6pF	±0.05pF	GRM0335C2A5R6WA01#
±0.1pF	GRM0335C2A5R6BA01#					
±0.25pF	GRM0335C2A5R6CA01#					
±0.5pF	±0.5pF	GRM0335C2A5R6DA01#				
	5.7pF	±0.05pF	GRM0335C2A5R7WA01#			
		±0.1pF	GRM0335C2A5R7BA01#			

品名 # 表示包装规格代码。

GRM 系列
GJM 系列
GMA 系列
GMD 系列
GQM 系列
GRJ 系列
GR3 系列
KRM 系列
KR3 系列
LLA 系列
LLL 系列
LLM 系列
LLR 系列
警告/注意事项

GRM 系列温度补偿型品名列表

(→ ■ 0.6×0.3mm)

T 最大值	额定 电压	温度特 性代号	静电容量	公差	品名
0.33mm	100Vdc	C0G	5.7pF	±0.25pF	GRM0335C2A5R7CA01#
				±0.5pF	GRM0335C2A5R7DA01#
			5.8pF	±0.05pF	GRM0335C2A5R8WA01#
				±0.1pF	GRM0335C2A5R8BA01#
				±0.25pF	GRM0335C2A5R8CA01#
				±0.5pF	GRM0335C2A5R8DA01#
			5.9pF	±0.05pF	GRM0335C2A5R9WA01#
				±0.1pF	GRM0335C2A5R9BA01#
				±0.25pF	GRM0335C2A5R9CA01#
				±0.5pF	GRM0335C2A5R9DA01#
			6.0pF	±0.05pF	GRM0335C2A6R0WA01#
				±0.1pF	GRM0335C2A6R0BA01#
				±0.25pF	GRM0335C2A6R0CA01#
				±0.5pF	GRM0335C2A6R0DA01#
			6.1pF	±0.05pF	GRM0335C2A6R1WA01#
				±0.1pF	GRM0335C2A6R1BA01#
				±0.25pF	GRM0335C2A6R1CA01#
				±0.5pF	GRM0335C2A6R1DA01#
			6.2pF	±0.05pF	GRM0335C2A6R2WA01#
				±0.1pF	GRM0335C2A6R2BA01#
				±0.25pF	GRM0335C2A6R2CA01#
				±0.5pF	GRM0335C2A6R2DA01#
			6.3pF	±0.05pF	GRM0335C2A6R3WA01#
				±0.1pF	GRM0335C2A6R3BA01#
				±0.25pF	GRM0335C2A6R3CA01#
				±0.5pF	GRM0335C2A6R3DA01#
			6.4pF	±0.05pF	GRM0335C2A6R4WA01#
				±0.1pF	GRM0335C2A6R4BA01#
				±0.25pF	GRM0335C2A6R4CA01#
				±0.5pF	GRM0335C2A6R4DA01#
			6.5pF	±0.05pF	GRM0335C2A6R5WA01#
				±0.1pF	GRM0335C2A6R5BA01#
				±0.25pF	GRM0335C2A6R5CA01#
				±0.5pF	GRM0335C2A6R5DA01#
			6.6pF	±0.05pF	GRM0335C2A6R6WA01#
				±0.1pF	GRM0335C2A6R6BA01#
				±0.25pF	GRM0335C2A6R6CA01#
				±0.5pF	GRM0335C2A6R6DA01#
			6.7pF	±0.05pF	GRM0335C2A6R7WA01#
				±0.1pF	GRM0335C2A6R7BA01#
				±0.25pF	GRM0335C2A6R7CA01#
				±0.5pF	GRM0335C2A6R7DA01#
			6.8pF	±0.05pF	GRM0335C2A6R8WA01#
				±0.1pF	GRM0335C2A6R8BA01#
				±0.25pF	GRM0335C2A6R8CA01#
				±0.5pF	GRM0335C2A6R8DA01#
			6.9pF	±0.05pF	GRM0335C2A6R9WA01#
				±0.1pF	GRM0335C2A6R9BA01#
±0.25pF	GRM0335C2A6R9CA01#				
±0.5pF	GRM0335C2A6R9DA01#				
7.0pF	±0.05pF	GRM0335C2A7R0WA01#			
	±0.1pF	GRM0335C2A7R0BA01#			
	±0.25pF	GRM0335C2A7R0CA01#			
	±0.5pF	GRM0335C2A7R0DA01#			

T 最大值	额定 电压	温度特 性代号	静电容量	公差	品名
0.33mm	100Vdc	C0G	7.1pF	±0.05pF	GRM0335C2A7R1WA01#
				±0.1pF	GRM0335C2A7R1BA01#
				±0.25pF	GRM0335C2A7R1CA01#
				±0.5pF	GRM0335C2A7R1DA01#
			7.2pF	±0.05pF	GRM0335C2A7R2WA01#
				±0.1pF	GRM0335C2A7R2BA01#
				±0.25pF	GRM0335C2A7R2CA01#
				±0.5pF	GRM0335C2A7R2DA01#
			7.3pF	±0.05pF	GRM0335C2A7R3WA01#
				±0.1pF	GRM0335C2A7R3BA01#
				±0.25pF	GRM0335C2A7R3CA01#
				±0.5pF	GRM0335C2A7R3DA01#
			7.4pF	±0.05pF	GRM0335C2A7R4WA01#
				±0.1pF	GRM0335C2A7R4BA01#
				±0.25pF	GRM0335C2A7R4CA01#
				±0.5pF	GRM0335C2A7R4DA01#
			7.5pF	±0.05pF	GRM0335C2A7R5WA01#
				±0.1pF	GRM0335C2A7R5BA01#
				±0.25pF	GRM0335C2A7R5CA01#
				±0.5pF	GRM0335C2A7R5DA01#
			7.6pF	±0.05pF	GRM0335C2A7R6WA01#
				±0.1pF	GRM0335C2A7R6BA01#
				±0.25pF	GRM0335C2A7R6CA01#
				±0.5pF	GRM0335C2A7R6DA01#
			7.7pF	±0.05pF	GRM0335C2A7R7WA01#
				±0.1pF	GRM0335C2A7R7BA01#
				±0.25pF	GRM0335C2A7R7CA01#
				±0.5pF	GRM0335C2A7R7DA01#
			7.8pF	±0.05pF	GRM0335C2A7R8WA01#
				±0.1pF	GRM0335C2A7R8BA01#
				±0.25pF	GRM0335C2A7R8CA01#
				±0.5pF	GRM0335C2A7R8DA01#
			7.9pF	±0.05pF	GRM0335C2A7R9WA01#
				±0.1pF	GRM0335C2A7R9BA01#
				±0.25pF	GRM0335C2A7R9CA01#
				±0.5pF	GRM0335C2A7R9DA01#
			8.0pF	±0.05pF	GRM0335C2A8R0WA01#
				±0.1pF	GRM0335C2A8R0BA01#
				±0.25pF	GRM0335C2A8R0CA01#
				±0.5pF	GRM0335C2A8R0DA01#
			8.1pF	±0.05pF	GRM0335C2A8R1WA01#
				±0.1pF	GRM0335C2A8R1BA01#
				±0.25pF	GRM0335C2A8R1CA01#
				±0.5pF	GRM0335C2A8R1DA01#
			8.2pF	±0.05pF	GRM0335C2A8R2WA01#
				±0.1pF	GRM0335C2A8R2BA01#
				±0.25pF	GRM0335C2A8R2CA01#
				±0.5pF	GRM0335C2A8R2DA01#
8.3pF	±0.05pF	GRM0335C2A8R3WA01#			
	±0.1pF	GRM0335C2A8R3BA01#			
	±0.25pF	GRM0335C2A8R3CA01#			
	±0.5pF	GRM0335C2A8R3DA01#			
8.4pF	±0.05pF	GRM0335C2A8R4WA01#			
	±0.1pF	GRM0335C2A8R4BA01#			

品名 # 表示包装规格代码。

- GRM 系列
- GJM 系列
- GMA 系列
- GMD 系列
- GQM 系列
- GRJ 系列
- GR3 系列
- KRM 系列
- KR3 系列
- LJA 系列
- LLL 系列
- LLM 系列
- LLR 系列
- 警告 / 注意事項

GRM 系列温度补偿型品名列表

(→ ■ 0.6×0.3mm)

T 最大值	额定 电压	温度特 性代号	静电容量	公差	品名
0.33mm	100Vdc	C0G	8.4pF	±0.25pF	GRM0335C2A8R4CA01#
				±0.5pF	GRM0335C2A8R4DA01#
			8.5pF	±0.05pF	GRM0335C2A8R5WA01#
				±0.1pF	GRM0335C2A8R5BA01#
				±0.25pF	GRM0335C2A8R5CA01#
				±0.5pF	GRM0335C2A8R5DA01#
			8.6pF	±0.05pF	GRM0335C2A8R6WA01#
				±0.1pF	GRM0335C2A8R6BA01#
				±0.25pF	GRM0335C2A8R6CA01#
				±0.5pF	GRM0335C2A8R6DA01#
			8.7pF	±0.05pF	GRM0335C2A8R7WA01#
				±0.1pF	GRM0335C2A8R7BA01#
				±0.25pF	GRM0335C2A8R7CA01#
				±0.5pF	GRM0335C2A8R7DA01#
			8.8pF	±0.05pF	GRM0335C2A8R8WA01#
				±0.1pF	GRM0335C2A8R8BA01#
				±0.25pF	GRM0335C2A8R8CA01#
				±0.5pF	GRM0335C2A8R8DA01#
			8.9pF	±0.05pF	GRM0335C2A8R9WA01#
				±0.1pF	GRM0335C2A8R9BA01#
				±0.25pF	GRM0335C2A8R9CA01#
				±0.5pF	GRM0335C2A8R9DA01#
			9.0pF	±0.05pF	GRM0335C2A9R0WA01#
				±0.1pF	GRM0335C2A9R0BA01#
				±0.25pF	GRM0335C2A9R0CA01#
				±0.5pF	GRM0335C2A9R0DA01#
			9.1pF	±0.05pF	GRM0335C2A9R1WA01#
				±0.1pF	GRM0335C2A9R1BA01#
				±0.25pF	GRM0335C2A9R1CA01#
				±0.5pF	GRM0335C2A9R1DA01#
			9.2pF	±0.05pF	GRM0335C2A9R2WA01#
				±0.1pF	GRM0335C2A9R2BA01#
				±0.25pF	GRM0335C2A9R2CA01#
				±0.5pF	GRM0335C2A9R2DA01#
			9.3pF	±0.05pF	GRM0335C2A9R3WA01#
				±0.1pF	GRM0335C2A9R3BA01#
				±0.25pF	GRM0335C2A9R3CA01#
				±0.5pF	GRM0335C2A9R3DA01#
			9.4pF	±0.05pF	GRM0335C2A9R4WA01#
				±0.1pF	GRM0335C2A9R4BA01#
				±0.25pF	GRM0335C2A9R4CA01#
				±0.5pF	GRM0335C2A9R4DA01#
			9.5pF	±0.05pF	GRM0335C2A9R5WA01#
				±0.1pF	GRM0335C2A9R5BA01#
				±0.25pF	GRM0335C2A9R5CA01#
				±0.5pF	GRM0335C2A9R5DA01#
			9.6pF	±0.05pF	GRM0335C2A9R6WA01#
				±0.1pF	GRM0335C2A9R6BA01#
				±0.25pF	GRM0335C2A9R6CA01#
				±0.5pF	GRM0335C2A9R6DA01#
			9.7pF	±0.05pF	GRM0335C2A9R7WA01#
				±0.1pF	GRM0335C2A9R7BA01#
				±0.25pF	GRM0335C2A9R7CA01#
				±0.5pF	GRM0335C2A9R7DA01#

T 最大值	额定 电压	温度特 性代号	静电容量	公差	品名	
0.33mm	100Vdc	C0G	9.8pF	±0.05pF	GRM0335C2A9R8WA01#	
				±0.1pF	GRM0335C2A9R8BA01#	
				±0.25pF	GRM0335C2A9R8CA01#	
				±0.5pF	GRM0335C2A9R8DA01#	
			9.9pF	±0.05pF	GRM0335C2A9R9WA01#	
				±0.1pF	GRM0335C2A9R9BA01#	
				±0.25pF	GRM0335C2A9R9CA01#	
				±0.5pF	GRM0335C2A9R9DA01#	
				10pF	±2%	GRM0335C2A100GA01#
					±5%	GRM0335C2A100JA01#
			12pF	±2%	GRM0335C2A120GA01#	
				±5%	GRM0335C2A120JA01#	
			15pF	±2%	GRM0335C2A150GA01#	
				±5%	GRM0335C2A150JA01#	
			CK	0.10pF	±0.05pF	GRM0334C2AR10WA01#
					±0.05pF	GRM0334C2AR20WA01#
					±0.1pF	GRM0334C2AR20BA01#
				0.30pF	±0.05pF	GRM0334C2AR30WA01#
					±0.1pF	GRM0334C2AR30BA01#
				0.40pF	±0.05pF	GRM0334C2AR40WA01#
					±0.1pF	GRM0334C2AR40BA01#
		0.50pF		±0.05pF	GRM0334C2AR50WA01#	
				±0.1pF	GRM0334C2AR50BA01#	
		0.60pF		±0.05pF	GRM0334C2AR60WA01#	
				±0.1pF	GRM0334C2AR60BA01#	
		0.70pF		±0.05pF	GRM0334C2AR70WA01#	
				±0.1pF	GRM0334C2AR70BA01#	
		0.80pF		±0.05pF	GRM0334C2AR80WA01#	
				±0.1pF	GRM0334C2AR80BA01#	
		0.90pF		±0.05pF	GRM0334C2AR90WA01#	
				±0.1pF	GRM0334C2AR90BA01#	
		1.0pF		±0.05pF	GRM0334C2A1R0WA01#	
				±0.1pF	GRM0334C2A1R0BA01#	
				±0.25pF	GRM0334C2A1R0CA01#	
				±0.5pF	GRM0334C2A1R0DA01#	
		1.1pF	±0.05pF	GRM0334C2A1R1WA01#		
			±0.1pF	GRM0334C2A1R1BA01#		
			±0.25pF	GRM0334C2A1R1CA01#		
		1.2pF	±0.05pF	GRM0334C2A1R2WA01#		
			±0.1pF	GRM0334C2A1R2BA01#		
			±0.25pF	GRM0334C2A1R2CA01#		
		1.3pF	±0.05pF	GRM0334C2A1R3WA01#		
±0.1pF	GRM0334C2A1R3BA01#					
±0.25pF	GRM0334C2A1R3CA01#					
1.4pF	±0.05pF	GRM0334C2A1R4WA01#				
	±0.1pF	GRM0334C2A1R4BA01#				
	±0.25pF	GRM0334C2A1R4CA01#				
1.5pF	±0.05pF	GRM0334C2A1R5WA01#				
	±0.1pF	GRM0334C2A1R5BA01#				
	±0.25pF	GRM0334C2A1R5CA01#				
1.6pF	±0.05pF	GRM0334C2A1R6WA01#				
	±0.1pF	GRM0334C2A1R6BA01#				
	±0.25pF	GRM0334C2A1R6CA01#				
1.7pF	±0.05pF	GRM0334C2A1R7WA01#				
	±0.1pF	GRM0334C2A1R7BA01#				

品名 # 表示包装规格代码。

GRM 系列
GJM 系列
GMA 系列
GMD 系列
GQM 系列
GRJ 系列
GR3 系列
KRM 系列
KR3 系列
LLA 系列
LLL 系列
LLM 系列
LLR 系列
警告/注意事项

GRM 系列温度补偿型品名列表

(→ ■ 0.6×0.3mm)

T 最大值	额定 电压	温度特 性代号	静电容量	公差	品名	
0.33mm	100Vdc	CK	1.7pF	±0.25pF	GRM0334C2A1R7CA01#	
				±0.05pF	GRM0334C2A1R8WA01#	
					±0.1pF	GRM0334C2A1R8BA01#
			±0.25pF	GRM0334C2A1R8CA01#		
				1.9pF	±0.05pF	GRM0334C2A1R9WA01#
					±0.1pF	GRM0334C2A1R9BA01#
			±0.25pF	GRM0334C2A1R9CA01#		
			2.0pF	±0.05pF	GRM0334C2A2R0WA01#	
				±0.1pF	GRM0334C2A2R0BA01#	
				±0.25pF	GRM0334C2A2R0CA01#	
			CJ	2.1pF	±0.05pF	GRM0333C2A2R1WA01#
					±0.1pF	GRM0333C2A2R1BA01#
					±0.25pF	GRM0333C2A2R1CA01#
				2.2pF	±0.05pF	GRM0333C2A2R2WA01#
					±0.1pF	GRM0333C2A2R2BA01#
					±0.25pF	GRM0333C2A2R2CA01#
				2.3pF	±0.05pF	GRM0333C2A2R3WA01#
					±0.1pF	GRM0333C2A2R3BA01#
		±0.25pF			GRM0333C2A2R3CA01#	
		2.4pF		±0.05pF	GRM0333C2A2R4WA01#	
				±0.1pF	GRM0333C2A2R4BA01#	
				±0.25pF	GRM0333C2A2R4CA01#	
		2.5pF		±0.05pF	GRM0333C2A2R5WA01#	
				±0.1pF	GRM0333C2A2R5BA01#	
				±0.25pF	GRM0333C2A2R5CA01#	
		2.6pF		±0.05pF	GRM0333C2A2R6WA01#	
				±0.1pF	GRM0333C2A2R6BA01#	
				±0.25pF	GRM0333C2A2R6CA01#	
		2.7pF	±0.05pF	GRM0333C2A2R7WA01#		
			±0.1pF	GRM0333C2A2R7BA01#		
			±0.25pF	GRM0333C2A2R7CA01#		
		2.8pF	±0.05pF	GRM0333C2A2R8WA01#		
			±0.1pF	GRM0333C2A2R8BA01#		
			±0.25pF	GRM0333C2A2R8CA01#		
		2.9pF	±0.05pF	GRM0333C2A2R9WA01#		
			±0.1pF	GRM0333C2A2R9BA01#		
			±0.25pF	GRM0333C2A2R9CA01#		
		3.0pF	±0.05pF	GRM0333C2A3R0WA01#		
			±0.1pF	GRM0333C2A3R0BA01#		
			±0.25pF	GRM0333C2A3R0CA01#		
		3.1pF	±0.05pF	GRM0333C2A3R1WA01#		
			±0.1pF	GRM0333C2A3R1BA01#		
			±0.25pF	GRM0333C2A3R1CA01#		
		3.2pF	±0.05pF	GRM0333C2A3R2WA01#		
			±0.1pF	GRM0333C2A3R2BA01#		
			±0.25pF	GRM0333C2A3R2CA01#		
		3.3pF	±0.05pF	GRM0333C2A3R3WA01#		
			±0.1pF	GRM0333C2A3R3BA01#		
			±0.25pF	GRM0333C2A3R3CA01#		
		3.4pF	±0.05pF	GRM0333C2A3R4WA01#		
			±0.1pF	GRM0333C2A3R4BA01#		
			±0.25pF	GRM0333C2A3R4CA01#		
		3.5pF	±0.05pF	GRM0333C2A3R5WA01#		
			±0.1pF	GRM0333C2A3R5BA01#		

T 最大值	额定 电压	温度特 性代号	静电容量	公差	品名	
0.33mm	100Vdc	CJ	3.5pF	±0.25pF	GRM0333C2A3R5CA01#	
				±0.05pF	GRM0333C2A3R6WA01#	
					±0.1pF	GRM0333C2A3R6BA01#
			±0.25pF	GRM0333C2A3R6CA01#		
				3.7pF	±0.05pF	GRM0333C2A3R7WA01#
					±0.1pF	GRM0333C2A3R7BA01#
			±0.25pF		GRM0333C2A3R7CA01#	
			3.8pF	±0.05pF	GRM0333C2A3R8WA01#	
				±0.1pF	GRM0333C2A3R8BA01#	
				±0.25pF	GRM0333C2A3R8CA01#	
			3.9pF	±0.05pF	GRM0333C2A3R9WA01#	
				±0.1pF	GRM0333C2A3R9BA01#	
				±0.25pF	GRM0333C2A3R9CA01#	
			CH	4.0pF	±0.05pF	GRM0332C2A4R0WA01#
					±0.1pF	GRM0332C2A4R0BA01#
					±0.25pF	GRM0332C2A4R0CA01#
				4.1pF	±0.05pF	GRM0332C2A4R1WA01#
					±0.1pF	GRM0332C2A4R1BA01#
		±0.25pF			GRM0332C2A4R1CA01#	
		4.2pF		±0.05pF	GRM0332C2A4R2WA01#	
				±0.1pF	GRM0332C2A4R2BA01#	
				±0.25pF	GRM0332C2A4R2CA01#	
		4.3pF		±0.05pF	GRM0332C2A4R3WA01#	
				±0.1pF	GRM0332C2A4R3BA01#	
				±0.25pF	GRM0332C2A4R3CA01#	
		4.4pF		±0.05pF	GRM0332C2A4R4WA01#	
				±0.1pF	GRM0332C2A4R4BA01#	
				±0.25pF	GRM0332C2A4R4CA01#	
		4.5pF		±0.05pF	GRM0332C2A4R5WA01#	
				±0.1pF	GRM0332C2A4R5BA01#	
				±0.25pF	GRM0332C2A4R5CA01#	
		4.6pF	±0.05pF	GRM0332C2A4R6WA01#		
			±0.1pF	GRM0332C2A4R6BA01#		
			±0.25pF	GRM0332C2A4R6CA01#		
		4.7pF	±0.05pF	GRM0332C2A4R7WA01#		
			±0.1pF	GRM0332C2A4R7BA01#		
			±0.25pF	GRM0332C2A4R7CA01#		
		4.8pF	±0.05pF	GRM0332C2A4R8WA01#		
			±0.1pF	GRM0332C2A4R8BA01#		
			±0.25pF	GRM0332C2A4R8CA01#		
		4.9pF	±0.05pF	GRM0332C2A4R9WA01#		
			±0.1pF	GRM0332C2A4R9BA01#		
			±0.25pF	GRM0332C2A4R9CA01#		
		5.0pF	±0.05pF	GRM0332C2A5R0WA01#		
			±0.1pF	GRM0332C2A5R0BA01#		
			±0.25pF	GRM0332C2A5R0CA01#		
		5.1pF	±0.05pF	GRM0332C2A5R1WA01#		
			±0.1pF	GRM0332C2A5R1BA01#		
			±0.25pF	GRM0332C2A5R1CA01#		
		5.2pF	±0.05pF	GRM0332C2A5R2WA01#		
			±0.1pF	GRM0332C2A5R2BA01#		
			±0.25pF	GRM0332C2A5R2CA01#		
		5.2pF	±0.05pF	GRM0332C2A5R2DA01#		
			±0.1pF	GRM0332C2A5R2BA01#		
±0.25pF	GRM0332C2A5R2CA01#					
5.2pF	±0.05pF	GRM0332C2A5R2DA01#				
	±0.1pF	GRM0332C2A5R2BA01#				
	±0.25pF	GRM0332C2A5R2CA01#				

品名 # 表示包装规格代码。

- GRM 系列
- GJM 系列
- GMA 系列
- GMD 系列
- GQM 系列
- GRJ 系列
- GR3 系列
- KRM 系列
- KR3 系列
- LJA 系列
- LLL 系列
- LLM 系列
- LLR 系列
- 警告 / 注意事項

GRM 系列温度补偿型品名列表

(→ ■ 0.6×0.3mm)

T 最大值	额定 电压	温度特 性代号	静电容量	公差	品名
0.33mm	100Vdc	CH	5.3pF	±0.05pF	GRM0332C2A5R3WA01#
				±0.1pF	GRM0332C2A5R3BA01#
				±0.25pF	GRM0332C2A5R3CA01#
				±0.5pF	GRM0332C2A5R3DA01#
			5.4pF	±0.05pF	GRM0332C2A5R4WA01#
				±0.1pF	GRM0332C2A5R4BA01#
				±0.25pF	GRM0332C2A5R4CA01#
				±0.5pF	GRM0332C2A5R4DA01#
			5.5pF	±0.05pF	GRM0332C2A5R5WA01#
				±0.1pF	GRM0332C2A5R5BA01#
				±0.25pF	GRM0332C2A5R5CA01#
				±0.5pF	GRM0332C2A5R5DA01#
			5.6pF	±0.05pF	GRM0332C2A5R6WA01#
				±0.1pF	GRM0332C2A5R6BA01#
				±0.25pF	GRM0332C2A5R6CA01#
				±0.5pF	GRM0332C2A5R6DA01#
			5.7pF	±0.05pF	GRM0332C2A5R7WA01#
				±0.1pF	GRM0332C2A5R7BA01#
				±0.25pF	GRM0332C2A5R7CA01#
				±0.5pF	GRM0332C2A5R7DA01#
			5.8pF	±0.05pF	GRM0332C2A5R8WA01#
				±0.1pF	GRM0332C2A5R8BA01#
				±0.25pF	GRM0332C2A5R8CA01#
				±0.5pF	GRM0332C2A5R8DA01#
			5.9pF	±0.05pF	GRM0332C2A5R9WA01#
				±0.1pF	GRM0332C2A5R9BA01#
				±0.25pF	GRM0332C2A5R9CA01#
				±0.5pF	GRM0332C2A5R9DA01#
			6.0pF	±0.05pF	GRM0332C2A6R0WA01#
				±0.1pF	GRM0332C2A6R0BA01#
				±0.25pF	GRM0332C2A6R0CA01#
				±0.5pF	GRM0332C2A6R0DA01#
			6.1pF	±0.05pF	GRM0332C2A6R1WA01#
				±0.1pF	GRM0332C2A6R1BA01#
				±0.25pF	GRM0332C2A6R1CA01#
				±0.5pF	GRM0332C2A6R1DA01#
			6.2pF	±0.05pF	GRM0332C2A6R2WA01#
				±0.1pF	GRM0332C2A6R2BA01#
				±0.25pF	GRM0332C2A6R2CA01#
				±0.5pF	GRM0332C2A6R2DA01#
			6.3pF	±0.05pF	GRM0332C2A6R3WA01#
				±0.1pF	GRM0332C2A6R3BA01#
				±0.25pF	GRM0332C2A6R3CA01#
				±0.5pF	GRM0332C2A6R3DA01#
			6.4pF	±0.05pF	GRM0332C2A6R4WA01#
				±0.1pF	GRM0332C2A6R4BA01#
				±0.25pF	GRM0332C2A6R4CA01#
				±0.5pF	GRM0332C2A6R4DA01#
			6.5pF	±0.05pF	GRM0332C2A6R5WA01#
				±0.1pF	GRM0332C2A6R5BA01#
				±0.25pF	GRM0332C2A6R5CA01#
				±0.5pF	GRM0332C2A6R5DA01#
			6.6pF	±0.05pF	GRM0332C2A6R6WA01#
				±0.1pF	GRM0332C2A6R6BA01#

T 最大值	额定 电压	温度特 性代号	静电容量	公差	品名		
0.33mm	100Vdc	CH	6.6pF	±0.25pF	GRM0332C2A6R6CA01#		
				±0.5pF	GRM0332C2A6R6DA01#		
			6.7pF	±0.05pF	GRM0332C2A6R7WA01#		
				±0.1pF	GRM0332C2A6R7BA01#		
				±0.25pF	GRM0332C2A6R7CA01#		
			6.8pF	±0.05pF	GRM0332C2A6R8WA01#		
				±0.1pF	GRM0332C2A6R8BA01#		
				±0.25pF	GRM0332C2A6R8CA01#		
			6.9pF	±0.05pF	GRM0332C2A6R9WA01#		
				±0.1pF	GRM0332C2A6R9BA01#		
				±0.25pF	GRM0332C2A6R9CA01#		
			7.0pF	±0.05pF	GRM0332C2A7R0WA01#		
				±0.1pF	GRM0332C2A7R0BA01#		
				±0.25pF	GRM0332C2A7R0CA01#		
			7.1pF	±0.05pF	GRM0332C2A7R1WA01#		
				±0.1pF	GRM0332C2A7R1BA01#		
				±0.25pF	GRM0332C2A7R1CA01#		
			7.2pF	±0.05pF	GRM0332C2A7R2WA01#		
				±0.1pF	GRM0332C2A7R2BA01#		
				±0.25pF	GRM0332C2A7R2CA01#		
			7.3pF	±0.05pF	GRM0332C2A7R3WA01#		
				±0.1pF	GRM0332C2A7R3BA01#		
				±0.25pF	GRM0332C2A7R3CA01#		
			7.4pF	±0.05pF	GRM0332C2A7R4WA01#		
				±0.1pF	GRM0332C2A7R4BA01#		
				±0.25pF	GRM0332C2A7R4CA01#		
			7.5pF	±0.05pF	GRM0332C2A7R5WA01#		
				±0.1pF	GRM0332C2A7R5BA01#		
				±0.25pF	GRM0332C2A7R5CA01#		
			7.6pF	±0.05pF	GRM0332C2A7R6WA01#		
				±0.1pF	GRM0332C2A7R6BA01#		
				±0.25pF	GRM0332C2A7R6CA01#		
			7.7pF	±0.05pF	GRM0332C2A7R7WA01#		
				±0.1pF	GRM0332C2A7R7BA01#		
				±0.25pF	GRM0332C2A7R7CA01#		
			7.8pF	±0.05pF	GRM0332C2A7R8WA01#		
				±0.1pF	GRM0332C2A7R8BA01#		
				±0.25pF	GRM0332C2A7R8CA01#		
			7.9pF	±0.05pF	GRM0332C2A7R9WA01#		
				±0.1pF	GRM0332C2A7R9BA01#		
				±0.25pF	GRM0332C2A7R9CA01#		
						±0.5pF	GRM0332C2A7R9DA01#

品名 # 表示包装规格代码。

GRM 系列
GJM 系列
GMA 系列
GMD 系列
GQM 系列
GRJ 系列
GR3 系列
KRM 系列
KR3 系列
LLA 系列
LLL 系列
LLM 系列
LLR 系列
警告/注意事项

GRM 系列温度补偿型品名列表

(→ ■ 0.6×0.3mm)

T 最大值	额定 电压	温度特 性代号	静电容量	公差	品名
0.33mm	100Vdc	CH	8.0pF	±0.05pF	GRM0332C2A8R0WA01#
				±0.1pF	GRM0332C2A8R0BA01#
				±0.25pF	GRM0332C2A8R0CA01#
				±0.5pF	GRM0332C2A8R0DA01#
			8.1pF	±0.05pF	GRM0332C2A8R1WA01#
				±0.1pF	GRM0332C2A8R1BA01#
				±0.25pF	GRM0332C2A8R1CA01#
				±0.5pF	GRM0332C2A8R1DA01#
			8.2pF	±0.05pF	GRM0332C2A8R2WA01#
				±0.1pF	GRM0332C2A8R2BA01#
				±0.25pF	GRM0332C2A8R2CA01#
				±0.5pF	GRM0332C2A8R2DA01#
			8.3pF	±0.05pF	GRM0332C2A8R3WA01#
				±0.1pF	GRM0332C2A8R3BA01#
				±0.25pF	GRM0332C2A8R3CA01#
				±0.5pF	GRM0332C2A8R3DA01#
			8.4pF	±0.05pF	GRM0332C2A8R4WA01#
				±0.1pF	GRM0332C2A8R4BA01#
				±0.25pF	GRM0332C2A8R4CA01#
				±0.5pF	GRM0332C2A8R4DA01#
			8.5pF	±0.05pF	GRM0332C2A8R5WA01#
				±0.1pF	GRM0332C2A8R5BA01#
				±0.25pF	GRM0332C2A8R5CA01#
				±0.5pF	GRM0332C2A8R5DA01#
			8.6pF	±0.05pF	GRM0332C2A8R6WA01#
				±0.1pF	GRM0332C2A8R6BA01#
				±0.25pF	GRM0332C2A8R6CA01#
				±0.5pF	GRM0332C2A8R6DA01#
			8.7pF	±0.05pF	GRM0332C2A8R7WA01#
				±0.1pF	GRM0332C2A8R7BA01#
				±0.25pF	GRM0332C2A8R7CA01#
				±0.5pF	GRM0332C2A8R7DA01#
			8.8pF	±0.05pF	GRM0332C2A8R8WA01#
				±0.1pF	GRM0332C2A8R8BA01#
				±0.25pF	GRM0332C2A8R8CA01#
				±0.5pF	GRM0332C2A8R8DA01#
			8.9pF	±0.05pF	GRM0332C2A8R9WA01#
				±0.1pF	GRM0332C2A8R9BA01#
				±0.25pF	GRM0332C2A8R9CA01#
				±0.5pF	GRM0332C2A8R9DA01#
			9.0pF	±0.05pF	GRM0332C2A9R0WA01#
				±0.1pF	GRM0332C2A9R0BA01#
				±0.25pF	GRM0332C2A9R0CA01#
				±0.5pF	GRM0332C2A9R0DA01#
			9.1pF	±0.05pF	GRM0332C2A9R1WA01#
				±0.1pF	GRM0332C2A9R1BA01#
				±0.25pF	GRM0332C2A9R1CA01#
				±0.5pF	GRM0332C2A9R1DA01#
			9.2pF	±0.05pF	GRM0332C2A9R2WA01#
				±0.1pF	GRM0332C2A9R2BA01#
				±0.25pF	GRM0332C2A9R2CA01#
				±0.5pF	GRM0332C2A9R2DA01#
			9.3pF	±0.05pF	GRM0332C2A9R3WA01#
				±0.1pF	GRM0332C2A9R3BA01#

T 最大值	额定 电压	温度特 性代号	静电容量	公差	品名		
0.33mm	100Vdc	CH	9.3pF	±0.25pF	GRM0332C2A9R3CA01#		
				±0.5pF	GRM0332C2A9R3DA01#		
				±0.05pF	GRM0332C2A9R4WA01#		
			9.4pF	±0.1pF	GRM0332C2A9R4BA01#		
				±0.25pF	GRM0332C2A9R4CA01#		
				±0.5pF	GRM0332C2A9R4DA01#		
			9.5pF	±0.05pF	GRM0332C2A9R5WA01#		
				±0.1pF	GRM0332C2A9R5BA01#		
				±0.25pF	GRM0332C2A9R5CA01#		
			9.6pF	±0.05pF	GRM0332C2A9R6WA01#		
				±0.1pF	GRM0332C2A9R6BA01#		
				±0.25pF	GRM0332C2A9R6CA01#		
			9.7pF	±0.05pF	GRM0332C2A9R7WA01#		
				±0.1pF	GRM0332C2A9R7BA01#		
				±0.25pF	GRM0332C2A9R7CA01#		
			9.8pF	±0.05pF	GRM0332C2A9R8WA01#		
				±0.1pF	GRM0332C2A9R8BA01#		
				±0.25pF	GRM0332C2A9R8CA01#		
			9.9pF	±0.05pF	GRM0332C2A9R9WA01#		
				±0.1pF	GRM0332C2A9R9BA01#		
				±0.25pF	GRM0332C2A9R9CA01#		
			10pF	±2%	GRM0332C2A100GA01#		
				±5%	GRM0332C2A100JA01#		
				12pF	±2%	GRM0332C2A120GA01#	
					±5%	GRM0332C2A120JA01#	
					15pF	±2%	GRM0332C2A150GA01#
				±5%		GRM0332C2A150JA01#	
			50Vdc	COG		0.10pF	±0.05pF
					±0.05pF		GRM0335C1HR20WA01#
					0.20pF	±0.05pF	GRM0335C1HR20BA01#
						±0.1pF	GRM0335C1HR20CA01#
					0.30pF	±0.05pF	GRM0335C1HR30WA01#
						±0.1pF	GRM0335C1HR30BA01#
					0.40pF	±0.05pF	GRM0335C1HR40WA01#
						±0.1pF	GRM0335C1HR40BA01#
					0.50pF	±0.05pF	GRM0335C1HR50WA01#
						±0.1pF	GRM0335C1HR50BA01#
					0.60pF	±0.05pF	GRM0335C1HR60WA01#
						±0.1pF	GRM0335C1HR60BA01#
					0.70pF	±0.05pF	GRM0335C1HR70WA01#
						±0.1pF	GRM0335C1HR70BA01#
					0.80pF	±0.05pF	GRM0335C1HR80WA01#
						±0.1pF	GRM0335C1HR80BA01#
					0.90pF	±0.05pF	GRM0335C1HR90WA01#
						±0.1pF	GRM0335C1HR90BA01#
					1.0pF	±0.05pF	GRM0335C1H1R0WA01#
						±0.1pF	GRM0335C1H1R0BA01#
						±0.25pF	GRM0335C1H1R0CA01#
					1.1pF	±0.05pF	GRM0335C1H1R1WA01#
						±0.1pF	GRM0335C1H1R1BA01#

品名 # 表示包装规格代码。

- GRM 系列
- GJM 系列
- GMA 系列
- GMD 系列
- GQM 系列
- GRJ 系列
- GR3 系列
- KRM 系列
- KR3 系列
- LJA 系列
- LLL 系列
- LLM 系列
- LLR 系列
- 警告 / 注意事项

GRM 系列温度补偿型品名列表

(→ ■ 0.6×0.3mm)

T 最大值	额定 电压	温度特 性代号	静电容量	公差	品名
0.33mm	50Vdc	C0G	1.1pF	±0.25pF	GRM0335C1H1R1CA01#
				±0.05pF	GRM0335C1H1R2WA01#
					±0.1pF
			±0.25pF	GRM0335C1H1R2CA01#	
				±0.05pF	GRM0335C1H1R3WA01#
					±0.1pF
			±0.25pF	GRM0335C1H1R3CA01#	
				±0.05pF	GRM0335C1H1R4WA01#
					±0.1pF
			±0.25pF	GRM0335C1H1R4CA01#	
				±0.05pF	GRM0335C1H1R5WA01#
					±0.1pF
			±0.25pF	GRM0335C1H1R5CA01#	
				±0.05pF	GRM0335C1H1R6WA01#
					±0.1pF
			±0.25pF	GRM0335C1H1R6CA01#	
				±0.05pF	GRM0335C1H1R7WA01#
					±0.1pF
			±0.25pF	GRM0335C1H1R7CA01#	
				±0.05pF	GRM0335C1H1R8WA01#
					±0.1pF
			±0.25pF	GRM0335C1H1R8CA01#	
				±0.05pF	GRM0335C1H1R9WA01#
					±0.1pF
			±0.25pF	GRM0335C1H1R9CA01#	
				±0.05pF	GRM0335C1H2R0WA01#
					±0.1pF
			±0.25pF	GRM0335C1H2R0CA01#	
				±0.05pF	GRM0335C1H2R1WA01#
					±0.1pF
			±0.25pF	GRM0335C1H2R1CA01#	
				±0.05pF	GRM0335C1H2R2WA01#
					±0.1pF
			±0.25pF	GRM0335C1H2R2CA01#	
				±0.05pF	GRM0335C1H2R3WA01#
					±0.1pF
			±0.25pF	GRM0335C1H2R3CA01#	
				±0.05pF	GRM0335C1H2R4WA01#
					±0.1pF
			±0.25pF	GRM0335C1H2R4CA01#	
				±0.05pF	GRM0335C1H2R5WA01#
					±0.1pF
±0.25pF	GRM0335C1H2R5CA01#				
	±0.05pF	GRM0335C1H2R6WA01#			
		±0.1pF	GRM0335C1H2R6BA01#		
±0.25pF	GRM0335C1H2R6CA01#				
	±0.05pF	GRM0335C1H2R7WA01#			
		±0.1pF	GRM0335C1H2R7BA01#		
±0.25pF	GRM0335C1H2R7CA01#				
	±0.05pF	GRM0335C1H2R8WA01#			
		±0.1pF	GRM0335C1H2R8BA01#		
±0.25pF	GRM0335C1H2R8CA01#				
	±0.05pF	GRM0335C1H2R9WA01#			
		±0.1pF	GRM0335C1H2R9BA01#		

T 最大值	额定 电压	温度特 性代号	静电容量	公差	品名
0.33mm	50Vdc	C0G	2.9pF	±0.25pF	GRM0335C1H2R9CA01#
				±0.05pF	GRM0335C1H3R0WA01#
					±0.1pF
			±0.25pF	GRM0335C1H3R0CA01#	
				±0.05pF	GRM0335C1H3R1WA01#
					±0.1pF
			±0.25pF	GRM0335C1H3R1CA01#	
				±0.05pF	GRM0335C1H3R2WA01#
					±0.1pF
			±0.25pF	GRM0335C1H3R2CA01#	
				±0.05pF	GRM0335C1H3R3WA01#
					±0.1pF
			±0.25pF	GRM0335C1H3R3CA01#	
				±0.05pF	GRM0335C1H3R4WA01#
					±0.1pF
			±0.25pF	GRM0335C1H3R4CA01#	
				±0.05pF	GRM0335C1H3R5WA01#
					±0.1pF
			±0.25pF	GRM0335C1H3R5CA01#	
				±0.05pF	GRM0335C1H3R6WA01#
					±0.1pF
			±0.25pF	GRM0335C1H3R6CA01#	
				±0.05pF	GRM0335C1H3R7WA01#
					±0.1pF
			±0.25pF	GRM0335C1H3R7CA01#	
				±0.05pF	GRM0335C1H3R8WA01#
					±0.1pF
			±0.25pF	GRM0335C1H3R8CA01#	
				±0.05pF	GRM0335C1H3R9WA01#
					±0.1pF
			±0.25pF	GRM0335C1H3R9CA01#	
				±0.05pF	GRM0335C1H4R0WA01#
					±0.1pF
			±0.25pF	GRM0335C1H4R0CA01#	
				±0.05pF	GRM0335C1H4R1WA01#
					±0.1pF
			±0.25pF	GRM0335C1H4R1CA01#	
				±0.05pF	GRM0335C1H4R2WA01#
					±0.1pF
			±0.25pF	GRM0335C1H4R2CA01#	
				±0.05pF	GRM0335C1H4R3WA01#
					±0.1pF
±0.25pF	GRM0335C1H4R3CA01#				
	±0.05pF	GRM0335C1H4R4WA01#			
		±0.1pF	GRM0335C1H4R4BA01#		
±0.25pF	GRM0335C1H4R4CA01#				
	±0.05pF	GRM0335C1H4R5WA01#			
		±0.1pF	GRM0335C1H4R5BA01#		
±0.25pF	GRM0335C1H4R5CA01#				
	±0.05pF	GRM0335C1H4R6WA01#			
		±0.1pF	GRM0335C1H4R6BA01#		
±0.25pF	GRM0335C1H4R6CA01#				
	±0.05pF	GRM0335C1H4R7WA01#			
		±0.1pF	GRM0335C1H4R7BA01#		

品名 # 表示包装规格代码。

GRM 系列
GJM 系列
GMA 系列
GMD 系列
GQM 系列
GRJ 系列
GR3 系列
KRM 系列
KR3 系列
LLA 系列
LLL 系列
LLM 系列
LLR 系列
警告/注意事项

GRM 系列温度补偿型品名列表

(→ ■ 0.6×0.3mm)

T 最大值	额定 电压	温度特 性代号	静电容量	公差	品名	
0.33mm	50Vdc	C0G	4.7pF	±0.25pF	GRM0335C1H4R7CA01#	
				±0.05pF	GRM0335C1H4R8WA01#	
					±0.1pF	GRM0335C1H4R8BA01#
					±0.25pF	GRM0335C1H4R8CA01#
			4.9pF	±0.05pF	GRM0335C1H4R9WA01#	
				±0.1pF	GRM0335C1H4R9BA01#	
				±0.25pF	GRM0335C1H4R9CA01#	
			5.0pF	±0.05pF	GRM0335C1H5R0WA01#	
				±0.1pF	GRM0335C1H5R0BA01#	
				±0.25pF	GRM0335C1H5R0CA01#	
			5.1pF	±0.05pF	GRM0335C1H5R1WA01#	
				±0.1pF	GRM0335C1H5R1BA01#	
				±0.25pF	GRM0335C1H5R1CA01#	
				±0.5pF	GRM0335C1H5R1DA01#	
			5.2pF	±0.05pF	GRM0335C1H5R2WA01#	
				±0.1pF	GRM0335C1H5R2BA01#	
				±0.25pF	GRM0335C1H5R2CA01#	
				±0.5pF	GRM0335C1H5R2DA01#	
			5.3pF	±0.05pF	GRM0335C1H5R3WA01#	
				±0.1pF	GRM0335C1H5R3BA01#	
				±0.25pF	GRM0335C1H5R3CA01#	
				±0.5pF	GRM0335C1H5R3DA01#	
			5.4pF	±0.05pF	GRM0335C1H5R4WA01#	
				±0.1pF	GRM0335C1H5R4BA01#	
				±0.25pF	GRM0335C1H5R4CA01#	
				±0.5pF	GRM0335C1H5R4DA01#	
			5.5pF	±0.05pF	GRM0335C1H5R5WA01#	
				±0.1pF	GRM0335C1H5R5BA01#	
				±0.25pF	GRM0335C1H5R5CA01#	
				±0.5pF	GRM0335C1H5R5DA01#	
			5.6pF	±0.05pF	GRM0335C1H5R6WA01#	
				±0.1pF	GRM0335C1H5R6BA01#	
				±0.25pF	GRM0335C1H5R6CA01#	
				±0.5pF	GRM0335C1H5R6DA01#	
			5.7pF	±0.05pF	GRM0335C1H5R7WA01#	
				±0.1pF	GRM0335C1H5R7BA01#	
				±0.25pF	GRM0335C1H5R7CA01#	
				±0.5pF	GRM0335C1H5R7DA01#	
			5.8pF	±0.05pF	GRM0335C1H5R8WA01#	
				±0.1pF	GRM0335C1H5R8BA01#	
				±0.25pF	GRM0335C1H5R8CA01#	
				±0.5pF	GRM0335C1H5R8DA01#	
			5.9pF	±0.05pF	GRM0335C1H5R9WA01#	
				±0.1pF	GRM0335C1H5R9BA01#	
				±0.25pF	GRM0335C1H5R9CA01#	
				±0.5pF	GRM0335C1H5R9DA01#	
			6.0pF	±0.05pF	GRM0335C1H6R0WA01#	
				±0.1pF	GRM0335C1H6R0BA01#	
				±0.25pF	GRM0335C1H6R0CA01#	
				±0.5pF	GRM0335C1H6R0DA01#	
			6.1pF	±0.05pF	GRM0335C1H6R1WA01#	
				±0.1pF	GRM0335C1H6R1BA01#	
				±0.25pF	GRM0335C1H6R1CA01#	
				±0.5pF	GRM0335C1H6R1DA01#	

T 最大值	额定 电压	温度特 性代号	静电容量	公差	品名
0.33mm	50Vdc	C0G	6.2pF	±0.05pF	GRM0335C1H6R2WA01#
				±0.1pF	GRM0335C1H6R2BA01#
				±0.25pF	GRM0335C1H6R2CA01#
				±0.5pF	GRM0335C1H6R2DA01#
				6.3pF	±0.05pF
			±0.1pF		GRM0335C1H6R3BA01#
			±0.25pF		GRM0335C1H6R3CA01#
			6.4pF	±0.05pF	GRM0335C1H6R4WA01#
				±0.1pF	GRM0335C1H6R4BA01#
				±0.25pF	GRM0335C1H6R4CA01#
			6.5pF	±0.05pF	GRM0335C1H6R5WA01#
				±0.1pF	GRM0335C1H6R5BA01#
				±0.25pF	GRM0335C1H6R5CA01#
			6.6pF	±0.05pF	GRM0335C1H6R6WA01#
				±0.1pF	GRM0335C1H6R6BA01#
				±0.25pF	GRM0335C1H6R6CA01#
			6.7pF	±0.05pF	GRM0335C1H6R7WA01#
				±0.1pF	GRM0335C1H6R7BA01#
				±0.25pF	GRM0335C1H6R7CA01#
			6.8pF	±0.05pF	GRM0335C1H6R8WA01#
				±0.1pF	GRM0335C1H6R8BA01#
				±0.25pF	GRM0335C1H6R8CA01#
			6.9pF	±0.05pF	GRM0335C1H6R9WA01#
				±0.1pF	GRM0335C1H6R9BA01#
				±0.25pF	GRM0335C1H6R9CA01#
			7.0pF	±0.05pF	GRM0335C1H7R0WA01#
				±0.1pF	GRM0335C1H7R0BA01#
				±0.25pF	GRM0335C1H7R0CA01#
			7.1pF	±0.05pF	GRM0335C1H7R1WA01#
				±0.1pF	GRM0335C1H7R1BA01#
				±0.25pF	GRM0335C1H7R1CA01#
			7.2pF	±0.05pF	GRM0335C1H7R2WA01#
				±0.1pF	GRM0335C1H7R2BA01#
				±0.25pF	GRM0335C1H7R2CA01#
			7.3pF	±0.05pF	GRM0335C1H7R3WA01#
				±0.1pF	GRM0335C1H7R3BA01#
				±0.25pF	GRM0335C1H7R3CA01#
			7.4pF	±0.05pF	GRM0335C1H7R4WA01#
				±0.1pF	GRM0335C1H7R4BA01#
				±0.25pF	GRM0335C1H7R4CA01#
			7.5pF	±0.05pF	GRM0335C1H7R5WA01#
				±0.1pF	GRM0335C1H7R5BA01#

品名 # 表示包装规格代码。

- GRM 系列
- GJM 系列
- GMA 系列
- GMD 系列
- GQM 系列
- GRJ 系列
- GR3 系列
- KRM 系列
- KR3 系列
- LJA 系列
- LLL 系列
- LLM 系列
- LLR 系列
- 警告 / 注意事项

GRM 系列温度补偿型品名列表

(→ ■ 0.6×0.3mm)

T 最大值	额定 电压	温度特 性代号	静电容量	公差	品名
0.33mm	50Vdc	C0G	7.5pF	±0.25pF	GRM0335C1H7R5CA01#
				±0.5pF	GRM0335C1H7R5DA01#
			7.6pF	±0.05pF	GRM0335C1H7R6WA01#
				±0.1pF	GRM0335C1H7R6BA01#
				±0.25pF	GRM0335C1H7R6CA01#
				±0.5pF	GRM0335C1H7R6DA01#
			7.7pF	±0.05pF	GRM0335C1H7R7WA01#
				±0.1pF	GRM0335C1H7R7BA01#
				±0.25pF	GRM0335C1H7R7CA01#
				±0.5pF	GRM0335C1H7R7DA01#
			7.8pF	±0.05pF	GRM0335C1H7R8WA01#
				±0.1pF	GRM0335C1H7R8BA01#
				±0.25pF	GRM0335C1H7R8CA01#
				±0.5pF	GRM0335C1H7R8DA01#
			7.9pF	±0.05pF	GRM0335C1H7R9WA01#
				±0.1pF	GRM0335C1H7R9BA01#
				±0.25pF	GRM0335C1H7R9CA01#
				±0.5pF	GRM0335C1H7R9DA01#
			8.0pF	±0.05pF	GRM0335C1H8R0WA01#
				±0.1pF	GRM0335C1H8R0BA01#
				±0.25pF	GRM0335C1H8R0CA01#
				±0.5pF	GRM0335C1H8R0DA01#
			8.1pF	±0.05pF	GRM0335C1H8R1WA01#
				±0.1pF	GRM0335C1H8R1BA01#
				±0.25pF	GRM0335C1H8R1CA01#
				±0.5pF	GRM0335C1H8R1DA01#
			8.2pF	±0.05pF	GRM0335C1H8R2WA01#
				±0.1pF	GRM0335C1H8R2BA01#
				±0.25pF	GRM0335C1H8R2CA01#
				±0.5pF	GRM0335C1H8R2DA01#
			8.3pF	±0.05pF	GRM0335C1H8R3WA01#
				±0.1pF	GRM0335C1H8R3BA01#
				±0.25pF	GRM0335C1H8R3CA01#
				±0.5pF	GRM0335C1H8R3DA01#
			8.4pF	±0.05pF	GRM0335C1H8R4WA01#
				±0.1pF	GRM0335C1H8R4BA01#
				±0.25pF	GRM0335C1H8R4CA01#
				±0.5pF	GRM0335C1H8R4DA01#
			8.5pF	±0.05pF	GRM0335C1H8R5WA01#
				±0.1pF	GRM0335C1H8R5BA01#
				±0.25pF	GRM0335C1H8R5CA01#
				±0.5pF	GRM0335C1H8R5DA01#
			8.6pF	±0.05pF	GRM0335C1H8R6WA01#
				±0.1pF	GRM0335C1H8R6BA01#
				±0.25pF	GRM0335C1H8R6CA01#
				±0.5pF	GRM0335C1H8R6DA01#
			8.7pF	±0.05pF	GRM0335C1H8R7WA01#
				±0.1pF	GRM0335C1H8R7BA01#
				±0.25pF	GRM0335C1H8R7CA01#
				±0.5pF	GRM0335C1H8R7DA01#
			8.8pF	±0.05pF	GRM0335C1H8R8WA01#
				±0.1pF	GRM0335C1H8R8BA01#
				±0.25pF	GRM0335C1H8R8CA01#
				±0.5pF	GRM0335C1H8R8DA01#

T 最大值	额定 电压	温度特 性代号	静电容量	公差	品名
0.33mm	50Vdc	C0G	8.9pF	±0.05pF	GRM0335C1H8R9WA01#
				±0.1pF	GRM0335C1H8R9BA01#
				±0.25pF	GRM0335C1H8R9CA01#
				±0.5pF	GRM0335C1H8R9DA01#
			9.0pF	±0.05pF	GRM0335C1H9R0WA01#
				±0.1pF	GRM0335C1H9R0BA01#
				±0.25pF	GRM0335C1H9R0CA01#
				±0.5pF	GRM0335C1H9R0DA01#
			9.1pF	±0.05pF	GRM0335C1H9R1WA01#
				±0.1pF	GRM0335C1H9R1BA01#
				±0.25pF	GRM0335C1H9R1CA01#
				±0.5pF	GRM0335C1H9R1DA01#
			9.2pF	±0.05pF	GRM0335C1H9R2WA01#
				±0.1pF	GRM0335C1H9R2BA01#
				±0.25pF	GRM0335C1H9R2CA01#
				±0.5pF	GRM0335C1H9R2DA01#
			9.3pF	±0.05pF	GRM0335C1H9R3WA01#
				±0.1pF	GRM0335C1H9R3BA01#
				±0.25pF	GRM0335C1H9R3CA01#
				±0.5pF	GRM0335C1H9R3DA01#
			9.4pF	±0.05pF	GRM0335C1H9R4WA01#
				±0.1pF	GRM0335C1H9R4BA01#
				±0.25pF	GRM0335C1H9R4CA01#
				±0.5pF	GRM0335C1H9R4DA01#
			9.5pF	±0.05pF	GRM0335C1H9R5WA01#
				±0.1pF	GRM0335C1H9R5BA01#
				±0.25pF	GRM0335C1H9R5CA01#
				±0.5pF	GRM0335C1H9R5DA01#
			9.6pF	±0.05pF	GRM0335C1H9R6WA01#
				±0.1pF	GRM0335C1H9R6BA01#
				±0.25pF	GRM0335C1H9R6CA01#
				±0.5pF	GRM0335C1H9R6DA01#
			9.7pF	±0.05pF	GRM0335C1H9R7WA01#
				±0.1pF	GRM0335C1H9R7BA01#
				±0.25pF	GRM0335C1H9R7CA01#
				±0.5pF	GRM0335C1H9R7DA01#
			9.8pF	±0.05pF	GRM0335C1H9R8WA01#
				±0.1pF	GRM0335C1H9R8BA01#
				±0.25pF	GRM0335C1H9R8CA01#
				±0.5pF	GRM0335C1H9R8DA01#
			9.9pF	±0.05pF	GRM0335C1H9R9WA01#
				±0.1pF	GRM0335C1H9R9BA01#
				±0.25pF	GRM0335C1H9R9CA01#
				±0.5pF	GRM0335C1H9R9DA01#
			10pF	±2%	GRM0335C1H100GA01#
				±5%	GRM0335C1H100JA01#
			12pF	±2%	GRM0335C1H120GA01#
				±5%	GRM0335C1H120JA01#
			15pF	±2%	GRM0335C1H150GA01#
				±5%	GRM0335C1H150JA01#
			18pF	±2%	GRM0335C1H180GA01#
				±5%	GRM0335C1H180JA01#
			22pF	±2%	GRM0335C1H220GA01#
				±5%	GRM0335C1H220JA01#

品名 # 表示包装规格代码。

GRM 系列
GJM 系列
GMA 系列
GMD 系列
GQM 系列
GRJ 系列
GR3 系列
KRM 系列
KR3 系列
LLA 系列
LLL 系列
LLM 系列
LLR 系列
警告/注意事项

GRM 系列温度补偿型品名列表

(→ ■ 0.6×0.3mm)

T 最大值	额定 电压	温度特 性代号	静电容量	公差	品名		
0.33mm	50Vdc	C0G	27pF	±2%	GRM0335C1H270GA01#		
				±5%	GRM0335C1H270JA01#		
			33pF	±2%	GRM0335C1H330GA01#		
				±5%	GRM0335C1H330JA01#		
			39pF	±2%	GRM0335C1H390GA01#		
				±5%	GRM0335C1H390JA01#		
			47pF	±2%	GRM0335C1H470GA01#		
				±5%	GRM0335C1H470JA01#		
			56pF	±2%	GRM0335C1H560GA01#		
				±5%	GRM0335C1H560JA01#		
			68pF	±2%	GRM0335C1H680GA01#		
				±5%	GRM0335C1H680JA01#		
			82pF	±2%	GRM0335C1H820GA01#		
				±5%	GRM0335C1H820JA01#		
			100pF	±2%	GRM0335C1H101GA01#		
				±5%	GRM0335C1H101JA01#		
			120pF	±2%	GRM0335C1H121GA01#		
				±5%	GRM0335C1H121JA01#		
			150pF	±2%	GRM0335C1H151GA01#		
				±5%	GRM0335C1H151JA01#		
			180pF	±2%	GRM0335C1H181GA01#		
				±5%	GRM0335C1H181JA01#		
			220pF	±2%	GRM0335C1H221GA01#		
				±5%	GRM0335C1H221JA01#		
		CK	50Vdc	CK	0.10pF	±0.05pF	GRM0334C1HR10WA01#
						±0.1pF	GRM0334C1HR10BA01#
					0.20pF	±0.05pF	GRM0334C1HR20WA01#
						±0.1pF	GRM0334C1HR20BA01#
					0.30pF	±0.05pF	GRM0334C1HR30WA01#
						±0.1pF	GRM0334C1HR30BA01#
					0.40pF	±0.05pF	GRM0334C1HR40WA01#
						±0.1pF	GRM0334C1HR40BA01#
					0.50pF	±0.05pF	GRM0334C1HR50WA01#
						±0.1pF	GRM0334C1HR50BA01#
					0.60pF	±0.05pF	GRM0334C1HR60WA01#
						±0.1pF	GRM0334C1HR60BA01#
					0.70pF	±0.05pF	GRM0334C1HR70WA01#
						±0.1pF	GRM0334C1HR70BA01#
					0.80pF	±0.05pF	GRM0334C1HR80WA01#
						±0.1pF	GRM0334C1HR80BA01#
					0.90pF	±0.05pF	GRM0334C1HR90WA01#
						±0.1pF	GRM0334C1HR90BA01#
					1.0pF	±0.05pF	GRM0334C1H1R0WA01#
						±0.1pF	GRM0334C1H1R0BA01#
						±0.25pF	GRM0334C1H1R0CA01#
					1.1pF	±0.05pF	GRM0334C1H1R1WA01#
						±0.1pF	GRM0334C1H1R1BA01#
						±0.25pF	GRM0334C1H1R1CA01#
1.2pF	±0.05pF	GRM0334C1H1R2WA01#					
	±0.1pF	GRM0334C1H1R2BA01#					
	±0.25pF	GRM0334C1H1R2CA01#					
1.3pF	±0.05pF	GRM0334C1H1R3WA01#					
	±0.1pF	GRM0334C1H1R3BA01#					
	±0.25pF	GRM0334C1H1R3CA01#					
1.4pF	±0.05pF	GRM0334C1H1R4WA01#					

T 最大值	额定 电压	温度特 性代号	静电容量	公差	品名			
0.33mm	50Vdc	CK	1.4pF	±0.1pF	GRM0334C1H1R4BA01#			
				±0.25pF	GRM0334C1H1R4CA01#			
			1.5pF	±0.05pF	GRM0334C1H1R5WA01#			
				±0.1pF	GRM0334C1H1R5BA01#			
			1.6pF	±0.05pF	GRM0334C1H1R6WA01#			
				±0.1pF	GRM0334C1H1R6BA01#			
			1.7pF	±0.05pF	GRM0334C1H1R7WA01#			
				±0.1pF	GRM0334C1H1R7BA01#			
			1.8pF	±0.05pF	GRM0334C1H1R8WA01#			
				±0.1pF	GRM0334C1H1R8BA01#			
			1.9pF	±0.05pF	GRM0334C1H1R9WA01#			
				±0.1pF	GRM0334C1H1R9BA01#			
			2.0pF	±0.05pF	GRM0334C1H2R0WA01#			
				±0.1pF	GRM0334C1H2R0BA01#			
			CJ	50Vdc	CJ	2.1pF	±0.05pF	GRM0333C1H2R1WA01#
							±0.1pF	GRM0333C1H2R1BA01#
						2.2pF	±0.05pF	GRM0333C1H2R2WA01#
							±0.1pF	GRM0333C1H2R2BA01#
						2.3pF	±0.05pF	GRM0333C1H2R3WA01#
							±0.1pF	GRM0333C1H2R3BA01#
						2.4pF	±0.05pF	GRM0333C1H2R4WA01#
							±0.1pF	GRM0333C1H2R4BA01#
						2.5pF	±0.05pF	GRM0333C1H2R5WA01#
							±0.1pF	GRM0333C1H2R5BA01#
		2.6pF				±0.05pF	GRM0333C1H2R6WA01#	
						±0.1pF	GRM0333C1H2R6BA01#	
		2.7pF				±0.05pF	GRM0333C1H2R7WA01#	
						±0.1pF	GRM0333C1H2R7BA01#	
		2.8pF				±0.05pF	GRM0333C1H2R8WA01#	
						±0.1pF	GRM0333C1H2R8BA01#	
		2.9pF				±0.05pF	GRM0333C1H2R9WA01#	
						±0.1pF	GRM0333C1H2R9BA01#	
		3.0pF				±0.05pF	GRM0333C1H3R0WA01#	
						±0.1pF	GRM0333C1H3R0BA01#	
						±0.25pF	GRM0333C1H3R0CA01#	
		3.1pF				±0.05pF	GRM0333C1H3R1WA01#	
						±0.1pF	GRM0333C1H3R1BA01#	
						±0.25pF	GRM0333C1H3R1CA01#	
		3.2pF	±0.05pF	GRM0333C1H3R2WA01#				

品名 # 表示包装规格代码。

- GRM 系列
- GJM 系列
- GMA 系列
- GMD 系列
- GQM 系列
- GRJ 系列
- GR3 系列
- KRM 系列
- KR3 系列
- LJA 系列
- LLL 系列
- LJM 系列
- LLR 系列
- 警告 / 注意事項

GRM 系列温度补偿型品名列表

(→ ■ 0.6×0.3mm)

T 最大值	额定 电压	温度特 性代号	静电容量	公差	品名
0.33mm	50Vdc	CJ	3.2pF	±0.1pF	GRM0333C1H3R2BA01#
				±0.25pF	GRM0333C1H3R2CA01#
			3.3pF	±0.05pF	GRM0333C1H3R3WA01#
				±0.1pF	GRM0333C1H3R3BA01#
				±0.25pF	GRM0333C1H3R3CA01#
			3.4pF	±0.05pF	GRM0333C1H3R4WA01#
				±0.1pF	GRM0333C1H3R4BA01#
				±0.25pF	GRM0333C1H3R4CA01#
			3.5pF	±0.05pF	GRM0333C1H3R5WA01#
				±0.1pF	GRM0333C1H3R5BA01#
				±0.25pF	GRM0333C1H3R5CA01#
			3.6pF	±0.05pF	GRM0333C1H3R6WA01#
				±0.1pF	GRM0333C1H3R6BA01#
				±0.25pF	GRM0333C1H3R6CA01#
			3.7pF	±0.05pF	GRM0333C1H3R7WA01#
				±0.1pF	GRM0333C1H3R7BA01#
				±0.25pF	GRM0333C1H3R7CA01#
			3.8pF	±0.05pF	GRM0333C1H3R8WA01#
				±0.1pF	GRM0333C1H3R8BA01#
				±0.25pF	GRM0333C1H3R8CA01#
			3.9pF	±0.05pF	GRM0333C1H3R9WA01#
				±0.1pF	GRM0333C1H3R9BA01#
				±0.25pF	GRM0333C1H3R9CA01#
			CH	4.0pF	±0.05pF
		±0.1pF			GRM0332C1H4R0BA01#
		±0.25pF			GRM0332C1H4R0CA01#
		4.1pF		±0.05pF	GRM0332C1H4R1WA01#
				±0.1pF	GRM0332C1H4R1BA01#
				±0.25pF	GRM0332C1H4R1CA01#
		4.2pF		±0.05pF	GRM0332C1H4R2WA01#
				±0.1pF	GRM0332C1H4R2BA01#
				±0.25pF	GRM0332C1H4R2CA01#
		4.3pF		±0.05pF	GRM0332C1H4R3WA01#
				±0.1pF	GRM0332C1H4R3BA01#
				±0.25pF	GRM0332C1H4R3CA01#
		4.4pF		±0.05pF	GRM0332C1H4R4WA01#
				±0.1pF	GRM0332C1H4R4BA01#
				±0.25pF	GRM0332C1H4R4CA01#
		4.5pF		±0.05pF	GRM0332C1H4R5WA01#
				±0.1pF	GRM0332C1H4R5BA01#
				±0.25pF	GRM0332C1H4R5CA01#
		4.6pF		±0.05pF	GRM0332C1H4R6WA01#
				±0.1pF	GRM0332C1H4R6BA01#
				±0.25pF	GRM0332C1H4R6CA01#
		4.7pF		±0.05pF	GRM0332C1H4R7WA01#
				±0.1pF	GRM0332C1H4R7BA01#
				±0.25pF	GRM0332C1H4R7CA01#
		4.8pF	±0.05pF	GRM0332C1H4R8WA01#	
±0.1pF	GRM0332C1H4R8BA01#				
±0.25pF	GRM0332C1H4R8CA01#				
4.9pF	±0.05pF	GRM0332C1H4R9WA01#			
	±0.1pF	GRM0332C1H4R9BA01#			
	±0.25pF	GRM0332C1H4R9CA01#			
5.0pF	±0.05pF	GRM0332C1H5R0WA01#			

T 最大值	额定 电压	温度特 性代号	静电容量	公差	品名
0.33mm	50Vdc	CH	5.0pF	±0.1pF	GRM0332C1H5R0BA01#
				±0.25pF	GRM0332C1H5R0CA01#
			5.1pF	±0.05pF	GRM0332C1H5R1WA01#
				±0.1pF	GRM0332C1H5R1BA01#
				±0.25pF	GRM0332C1H5R1CA01#
			5.2pF	±0.05pF	GRM0332C1H5R2WA01#
				±0.1pF	GRM0332C1H5R2BA01#
				±0.25pF	GRM0332C1H5R2CA01#
			5.3pF	±0.05pF	GRM0332C1H5R3WA01#
				±0.1pF	GRM0332C1H5R3BA01#
				±0.25pF	GRM0332C1H5R3CA01#
			5.4pF	±0.05pF	GRM0332C1H5R4WA01#
				±0.1pF	GRM0332C1H5R4BA01#
				±0.25pF	GRM0332C1H5R4CA01#
			5.5pF	±0.05pF	GRM0332C1H5R5WA01#
				±0.1pF	GRM0332C1H5R5BA01#
				±0.25pF	GRM0332C1H5R5CA01#
			5.6pF	±0.05pF	GRM0332C1H5R6WA01#
				±0.1pF	GRM0332C1H5R6BA01#
				±0.25pF	GRM0332C1H5R6CA01#
			5.7pF	±0.05pF	GRM0332C1H5R7WA01#
				±0.1pF	GRM0332C1H5R7BA01#
				±0.25pF	GRM0332C1H5R7CA01#
			5.8pF	±0.05pF	GRM0332C1H5R8WA01#
				±0.1pF	GRM0332C1H5R8BA01#
				±0.25pF	GRM0332C1H5R8CA01#
			5.9pF	±0.05pF	GRM0332C1H5R9WA01#
				±0.1pF	GRM0332C1H5R9BA01#
				±0.25pF	GRM0332C1H5R9CA01#
			6.0pF	±0.05pF	GRM0332C1H6R0WA01#
				±0.1pF	GRM0332C1H6R0BA01#
				±0.25pF	GRM0332C1H6R0CA01#
			6.1pF	±0.05pF	GRM0332C1H6R1WA01#
				±0.1pF	GRM0332C1H6R1BA01#
				±0.25pF	GRM0332C1H6R1CA01#
			6.2pF	±0.05pF	GRM0332C1H6R2WA01#
				±0.1pF	GRM0332C1H6R2BA01#
				±0.25pF	GRM0332C1H6R2CA01#
			6.3pF	±0.05pF	GRM0332C1H6R3WA01#
				±0.1pF	GRM0332C1H6R3BA01#
				±0.25pF	GRM0332C1H6R3CA01#
			±0.5pF	GRM0332C1H6R3DA01#	

品名 # 表示包装规格代码。

GRM 系列
GJM 系列
GMA 系列
GMD 系列
GQM 系列
GRJ 系列
GR3 系列
KRM 系列
KR3 系列
LLA 系列
LLL 系列
LLM 系列
LLR 系列
警告/注意事项

GRM 系列温度补偿型品名列表

(→ ■ 0.6×0.3mm)

T 最大值	额定 电压	温度特 性代号	静电容量	公差	品名
0.33mm	50Vdc	CH	6.4pF	±0.05pF	GRM0332C1H6R4WA01#
				±0.1pF	GRM0332C1H6R4BA01#
				±0.25pF	GRM0332C1H6R4CA01#
				±0.5pF	GRM0332C1H6R4DA01#
			6.5pF	±0.05pF	GRM0332C1H6R5WA01#
				±0.1pF	GRM0332C1H6R5BA01#
				±0.25pF	GRM0332C1H6R5CA01#
				±0.5pF	GRM0332C1H6R5DA01#
			6.6pF	±0.05pF	GRM0332C1H6R6WA01#
				±0.1pF	GRM0332C1H6R6BA01#
				±0.25pF	GRM0332C1H6R6CA01#
				±0.5pF	GRM0332C1H6R6DA01#
			6.7pF	±0.05pF	GRM0332C1H6R7WA01#
				±0.1pF	GRM0332C1H6R7BA01#
				±0.25pF	GRM0332C1H6R7CA01#
				±0.5pF	GRM0332C1H6R7DA01#
			6.8pF	±0.05pF	GRM0332C1H6R8WA01#
				±0.1pF	GRM0332C1H6R8BA01#
				±0.25pF	GRM0332C1H6R8CA01#
				±0.5pF	GRM0332C1H6R8DA01#
			6.9pF	±0.05pF	GRM0332C1H6R9WA01#
				±0.1pF	GRM0332C1H6R9BA01#
				±0.25pF	GRM0332C1H6R9CA01#
				±0.5pF	GRM0332C1H6R9DA01#
			7.0pF	±0.05pF	GRM0332C1H7R0WA01#
				±0.1pF	GRM0332C1H7R0BA01#
				±0.25pF	GRM0332C1H7R0CA01#
				±0.5pF	GRM0332C1H7R0DA01#
			7.1pF	±0.05pF	GRM0332C1H7R1WA01#
				±0.1pF	GRM0332C1H7R1BA01#
				±0.25pF	GRM0332C1H7R1CA01#
				±0.5pF	GRM0332C1H7R1DA01#
			7.2pF	±0.05pF	GRM0332C1H7R2WA01#
				±0.1pF	GRM0332C1H7R2BA01#
				±0.25pF	GRM0332C1H7R2CA01#
				±0.5pF	GRM0332C1H7R2DA01#
			7.3pF	±0.05pF	GRM0332C1H7R3WA01#
				±0.1pF	GRM0332C1H7R3BA01#
				±0.25pF	GRM0332C1H7R3CA01#
				±0.5pF	GRM0332C1H7R3DA01#
			7.4pF	±0.05pF	GRM0332C1H7R4WA01#
				±0.1pF	GRM0332C1H7R4BA01#
				±0.25pF	GRM0332C1H7R4CA01#
				±0.5pF	GRM0332C1H7R4DA01#
			7.5pF	±0.05pF	GRM0332C1H7R5WA01#
				±0.1pF	GRM0332C1H7R5BA01#
				±0.25pF	GRM0332C1H7R5CA01#
				±0.5pF	GRM0332C1H7R5DA01#
			7.6pF	±0.05pF	GRM0332C1H7R6WA01#
				±0.1pF	GRM0332C1H7R6BA01#
				±0.25pF	GRM0332C1H7R6CA01#
				±0.5pF	GRM0332C1H7R6DA01#
			7.7pF	±0.05pF	GRM0332C1H7R7WA01#
				±0.1pF	GRM0332C1H7R7BA01#

T 最大值	额定 电压	温度特 性代号	静电容量	公差	品名
0.33mm	50Vdc	CH	7.7pF	±0.25pF	GRM0332C1H7R7CA01#
				±0.5pF	GRM0332C1H7R7DA01#
			7.8pF	±0.05pF	GRM0332C1H7R8WA01#
				±0.1pF	GRM0332C1H7R8BA01#
				±0.25pF	GRM0332C1H7R8CA01#
			7.9pF	±0.05pF	GRM0332C1H7R9WA01#
				±0.1pF	GRM0332C1H7R9BA01#
				±0.25pF	GRM0332C1H7R9CA01#
			8.0pF	±0.05pF	GRM0332C1H8R0WA01#
				±0.1pF	GRM0332C1H8R0BA01#
				±0.25pF	GRM0332C1H8R0CA01#
			8.1pF	±0.05pF	GRM0332C1H8R1WA01#
				±0.1pF	GRM0332C1H8R1BA01#
				±0.25pF	GRM0332C1H8R1CA01#
			8.2pF	±0.05pF	GRM0332C1H8R2WA01#
				±0.1pF	GRM0332C1H8R2BA01#
				±0.25pF	GRM0332C1H8R2CA01#
			8.3pF	±0.05pF	GRM0332C1H8R3WA01#
				±0.1pF	GRM0332C1H8R3BA01#
				±0.25pF	GRM0332C1H8R3CA01#
			8.4pF	±0.05pF	GRM0332C1H8R4WA01#
				±0.1pF	GRM0332C1H8R4BA01#
				±0.25pF	GRM0332C1H8R4CA01#
			8.5pF	±0.05pF	GRM0332C1H8R5WA01#
				±0.1pF	GRM0332C1H8R5BA01#
				±0.25pF	GRM0332C1H8R5CA01#
			8.6pF	±0.05pF	GRM0332C1H8R6WA01#
				±0.1pF	GRM0332C1H8R6BA01#
				±0.25pF	GRM0332C1H8R6CA01#
			8.7pF	±0.05pF	GRM0332C1H8R7WA01#
				±0.1pF	GRM0332C1H8R7BA01#
				±0.25pF	GRM0332C1H8R7CA01#
			8.8pF	±0.05pF	GRM0332C1H8R8WA01#
				±0.1pF	GRM0332C1H8R8BA01#
				±0.25pF	GRM0332C1H8R8CA01#
			8.9pF	±0.05pF	GRM0332C1H8R9WA01#
				±0.1pF	GRM0332C1H8R9BA01#
				±0.25pF	GRM0332C1H8R9CA01#
			9.0pF	±0.05pF	GRM0332C1H9R0WA01#
				±0.1pF	GRM0332C1H9R0BA01#
				±0.25pF	GRM0332C1H9R0CA01#

品名 # 表示包装规格代码。

- GRM 系列
- GJM 系列
- GMA 系列
- GMD 系列
- GQM 系列
- GRJ 系列
- GR3 系列
- KRM 系列
- KR3 系列
- LJA 系列
- LLL 系列
- LJM 系列
- LLR 系列
- 警告 / 注意事項

GRM 系列温度补偿型品名列表

(→ ■ 0.6×0.3mm)

T 最大值	额定 电压	温度特 性代号	静电容量	公差	品名
0.33mm	50Vdc	CH	9.1pF	±0.05pF	GRM0332C1H9R1WA01#
				±0.1pF	GRM0332C1H9R1BA01#
				±0.25pF	GRM0332C1H9R1CA01#
				±0.5pF	GRM0332C1H9R1DA01#
			9.2pF	±0.05pF	GRM0332C1H9R2WA01#
				±0.1pF	GRM0332C1H9R2BA01#
				±0.25pF	GRM0332C1H9R2CA01#
				±0.5pF	GRM0332C1H9R2DA01#
			9.3pF	±0.05pF	GRM0332C1H9R3WA01#
				±0.1pF	GRM0332C1H9R3BA01#
				±0.25pF	GRM0332C1H9R3CA01#
				±0.5pF	GRM0332C1H9R3DA01#
			9.4pF	±0.05pF	GRM0332C1H9R4WA01#
				±0.1pF	GRM0332C1H9R4BA01#
				±0.25pF	GRM0332C1H9R4CA01#
				±0.5pF	GRM0332C1H9R4DA01#
			9.5pF	±0.05pF	GRM0332C1H9R5WA01#
				±0.1pF	GRM0332C1H9R5BA01#
				±0.25pF	GRM0332C1H9R5CA01#
				±0.5pF	GRM0332C1H9R5DA01#
			9.6pF	±0.05pF	GRM0332C1H9R6WA01#
				±0.1pF	GRM0332C1H9R6BA01#
				±0.25pF	GRM0332C1H9R6CA01#
				±0.5pF	GRM0332C1H9R6DA01#
			9.7pF	±0.05pF	GRM0332C1H9R7WA01#
				±0.1pF	GRM0332C1H9R7BA01#
				±0.25pF	GRM0332C1H9R7CA01#
				±0.5pF	GRM0332C1H9R7DA01#
			9.8pF	±0.05pF	GRM0332C1H9R8WA01#
				±0.1pF	GRM0332C1H9R8BA01#
				±0.25pF	GRM0332C1H9R8CA01#
				±0.5pF	GRM0332C1H9R8DA01#
			9.9pF	±0.05pF	GRM0332C1H9R9WA01#
				±0.1pF	GRM0332C1H9R9BA01#
				±0.25pF	GRM0332C1H9R9CA01#
				±0.5pF	GRM0332C1H9R9DA01#
			10pF	±2%	GRM0332C1H100GA01#
				±5%	GRM0332C1H100JA01#
			12pF	±2%	GRM0332C1H120GA01#
				±5%	GRM0332C1H120JA01#
			15pF	±2%	GRM0332C1H150GA01#
				±5%	GRM0332C1H150JA01#
			18pF	±2%	GRM0332C1H180GA01#
				±5%	GRM0332C1H180JA01#
			22pF	±2%	GRM0332C1H220GA01#
				±5%	GRM0332C1H220JA01#
			27pF	±2%	GRM0332C1H270GA01#
				±5%	GRM0332C1H270JA01#
33pF	±2%	GRM0332C1H330GA01#			
	±5%	GRM0332C1H330JA01#			
39pF	±2%	GRM0332C1H390GA01#			
	±5%	GRM0332C1H390JA01#			
47pF	±2%	GRM0332C1H470GA01#			
	±5%	GRM0332C1H470JA01#			

T 最大值	额定 电压	温度特 性代号	静电容量	公差	品名
0.33mm	50Vdc	CH	56pF	±2%	GRM0332C1H560GA01#
				±5%	GRM0332C1H560JA01#
			68pF	±2%	GRM0332C1H680GA01#
				±5%	GRM0332C1H680JA01#
			82pF	±2%	GRM0332C1H820GA01#
				±5%	GRM0332C1H820JA01#
			100pF	±2%	GRM0332C1H101GA01#
				±5%	GRM0332C1H101JA01#
			120pF	±2%	GRM0332C1H121GA01#
				±5%	GRM0332C1H121JA01#
			150pF	±2%	GRM0332C1H151GA01#
				±5%	GRM0332C1H151JA01#
			180pF	±2%	GRM0332C1H181GA01#
				±5%	GRM0332C1H181JA01#
			220pF	±2%	GRM0332C1H221GA01#
				±5%	GRM0332C1H221JA01#

■ 1.0×0.5mm

T 最大值	额定 电压	温度特 性代号	静电容量	公差	品名
0.55mm	100Vdc	C0G	0.10pF	±0.05pF	GRM1555C2AR10WA01#
				±0.05pF	GRM1555C2AR20WA01#
			0.20pF	±0.05pF	GRM1555C2AR20BA01#
				±0.1pF	GRM1555C2AR20CA01#
			0.30pF	±0.05pF	GRM1555C2AR30WA01#
				±0.1pF	GRM1555C2AR30BA01#
			0.40pF	±0.05pF	GRM1555C2AR40WA01#
				±0.1pF	GRM1555C2AR40BA01#
			0.50pF	±0.05pF	GRM1555C2AR50WA01#
				±0.1pF	GRM1555C2AR50BA01#
			0.60pF	±0.05pF	GRM1555C2AR60WA01#
				±0.1pF	GRM1555C2AR60BA01#
			0.70pF	±0.05pF	GRM1555C2AR70WA01#
				±0.1pF	GRM1555C2AR70BA01#
			0.80pF	±0.05pF	GRM1555C2AR80WA01#
				±0.1pF	GRM1555C2AR80BA01#
			0.90pF	±0.05pF	GRM1555C2AR90WA01#
				±0.1pF	GRM1555C2AR90BA01#
			1.0pF	±0.05pF	GRM1555C2A1R0WA01#
				±0.1pF	GRM1555C2A1R0BA01#
				±0.25pF	GRM1555C2A1R0CA01#
			1.1pF	±0.05pF	GRM1555C2A1R1WA01#
				±0.1pF	GRM1555C2A1R1BA01#
				±0.25pF	GRM1555C2A1R1CA01#
			1.2pF	±0.05pF	GRM1555C2A1R2WA01#
				±0.1pF	GRM1555C2A1R2BA01#
				±0.25pF	GRM1555C2A1R2CA01#
			1.3pF	±0.05pF	GRM1555C2A1R3WA01#
				±0.1pF	GRM1555C2A1R3BA01#
				±0.25pF	GRM1555C2A1R3CA01#
			1.4pF	±0.05pF	GRM1555C2A1R4WA01#
				±0.1pF	GRM1555C2A1R4BA01#
				±0.25pF	GRM1555C2A1R4CA01#
			1.5pF	±0.05pF	GRM1555C2A1R5WA01#

品名 # 表示包装规格代码。

GRM 系列
GJM 系列
GMA 系列
GMD 系列
GQM 系列
GRJ 系列
GR3 系列
KRM 系列
KR3 系列
LLA 系列
LLL 系列
LLM 系列
LLR 系列
警告/注意事项

GRM 系列温度补偿型品名列表

(→ ■ 1.0×0.5mm)

T 最大值	额定 电压	温度特 性代号	静电容量	公差	品名
0.55mm	100Vdc	COG	1.5pF	±0.1pF	GRM1555C2A1R5BA01#
				±0.25pF	GRM1555C2A1R5CA01#
			1.6pF	±0.05pF	GRM1555C2A1R6WA01#
				±0.1pF	GRM1555C2A1R6BA01#
				±0.25pF	GRM1555C2A1R6CA01#
			1.7pF	±0.05pF	GRM1555C2A1R7WA01#
				±0.1pF	GRM1555C2A1R7BA01#
				±0.25pF	GRM1555C2A1R7CA01#
			1.8pF	±0.05pF	GRM1555C2A1R8WA01#
				±0.1pF	GRM1555C2A1R8BA01#
				±0.25pF	GRM1555C2A1R8CA01#
			1.9pF	±0.05pF	GRM1555C2A1R9WA01#
				±0.1pF	GRM1555C2A1R9BA01#
				±0.25pF	GRM1555C2A1R9CA01#
			2.0pF	±0.05pF	GRM1555C2A2R0WA01#
				±0.1pF	GRM1555C2A2R0BA01#
				±0.25pF	GRM1555C2A2R0CA01#
			2.1pF	±0.05pF	GRM1555C2A2R1WA01#
				±0.1pF	GRM1555C2A2R1BA01#
				±0.25pF	GRM1555C2A2R1CA01#
			2.2pF	±0.05pF	GRM1555C2A2R2WA01#
				±0.1pF	GRM1555C2A2R2BA01#
				±0.25pF	GRM1555C2A2R2CA01#
			2.3pF	±0.05pF	GRM1555C2A2R3WA01#
				±0.1pF	GRM1555C2A2R3BA01#
				±0.25pF	GRM1555C2A2R3CA01#
			2.4pF	±0.05pF	GRM1555C2A2R4WA01#
				±0.1pF	GRM1555C2A2R4BA01#
				±0.25pF	GRM1555C2A2R4CA01#
			2.5pF	±0.05pF	GRM1555C2A2R5WA01#
				±0.1pF	GRM1555C2A2R5BA01#
				±0.25pF	GRM1555C2A2R5CA01#
			2.6pF	±0.05pF	GRM1555C2A2R6WA01#
				±0.1pF	GRM1555C2A2R6BA01#
				±0.25pF	GRM1555C2A2R6CA01#
			2.7pF	±0.05pF	GRM1555C2A2R7WA01#
				±0.1pF	GRM1555C2A2R7BA01#
				±0.25pF	GRM1555C2A2R7CA01#
			2.8pF	±0.05pF	GRM1555C2A2R8WA01#
				±0.1pF	GRM1555C2A2R8BA01#
				±0.25pF	GRM1555C2A2R8CA01#
			2.9pF	±0.05pF	GRM1555C2A2R9WA01#
				±0.1pF	GRM1555C2A2R9BA01#
				±0.25pF	GRM1555C2A2R9CA01#
			3.0pF	±0.05pF	GRM1555C2A3R0WA01#
				±0.1pF	GRM1555C2A3R0BA01#
				±0.25pF	GRM1555C2A3R0CA01#
			3.1pF	±0.05pF	GRM1555C2A3R1WA01#
				±0.1pF	GRM1555C2A3R1BA01#
				±0.25pF	GRM1555C2A3R1CA01#
			3.2pF	±0.05pF	GRM1555C2A3R2WA01#
				±0.1pF	GRM1555C2A3R2BA01#
				±0.25pF	GRM1555C2A3R2CA01#
3.3pF	±0.05pF	GRM1555C2A3R3WA01#			

T 最大值	额定 电压	温度特 性代号	静电容量	公差	品名
0.55mm	100Vdc	COG	3.3pF	±0.1pF	GRM1555C2A3R3BA01#
				±0.25pF	GRM1555C2A3R3CA01#
			3.4pF	±0.05pF	GRM1555C2A3R4WA01#
				±0.1pF	GRM1555C2A3R4BA01#
				±0.25pF	GRM1555C2A3R4CA01#
			3.5pF	±0.05pF	GRM1555C2A3R5WA01#
				±0.1pF	GRM1555C2A3R5BA01#
				±0.25pF	GRM1555C2A3R5CA01#
			3.6pF	±0.05pF	GRM1555C2A3R6WA01#
				±0.1pF	GRM1555C2A3R6BA01#
				±0.25pF	GRM1555C2A3R6CA01#
			3.7pF	±0.05pF	GRM1555C2A3R7WA01#
				±0.1pF	GRM1555C2A3R7BA01#
				±0.25pF	GRM1555C2A3R7CA01#
			3.8pF	±0.05pF	GRM1555C2A3R8WA01#
				±0.1pF	GRM1555C2A3R8BA01#
				±0.25pF	GRM1555C2A3R8CA01#
			3.9pF	±0.05pF	GRM1555C2A3R9WA01#
				±0.1pF	GRM1555C2A3R9BA01#
				±0.25pF	GRM1555C2A3R9CA01#
			4.0pF	±0.05pF	GRM1555C2A4R0WA01#
				±0.1pF	GRM1555C2A4R0BA01#
				±0.25pF	GRM1555C2A4R0CA01#
			4.1pF	±0.05pF	GRM1555C2A4R1WA01#
				±0.1pF	GRM1555C2A4R1BA01#
				±0.25pF	GRM1555C2A4R1CA01#
			4.2pF	±0.05pF	GRM1555C2A4R2WA01#
				±0.1pF	GRM1555C2A4R2BA01#
				±0.25pF	GRM1555C2A4R2CA01#
			4.3pF	±0.05pF	GRM1555C2A4R3WA01#
				±0.1pF	GRM1555C2A4R3BA01#
				±0.25pF	GRM1555C2A4R3CA01#
			4.4pF	±0.05pF	GRM1555C2A4R4WA01#
				±0.1pF	GRM1555C2A4R4BA01#
				±0.25pF	GRM1555C2A4R4CA01#
			4.5pF	±0.05pF	GRM1555C2A4R5WA01#
				±0.1pF	GRM1555C2A4R5BA01#
				±0.25pF	GRM1555C2A4R5CA01#
			4.6pF	±0.05pF	GRM1555C2A4R6WA01#
				±0.1pF	GRM1555C2A4R6BA01#
				±0.25pF	GRM1555C2A4R6CA01#
			4.7pF	±0.05pF	GRM1555C2A4R7WA01#
				±0.1pF	GRM1555C2A4R7BA01#
				±0.25pF	GRM1555C2A4R7CA01#
			4.8pF	±0.05pF	GRM1555C2A4R8WA01#
				±0.1pF	GRM1555C2A4R8BA01#
				±0.25pF	GRM1555C2A4R8CA01#
			4.9pF	±0.05pF	GRM1555C2A4R9WA01#
				±0.1pF	GRM1555C2A4R9BA01#
				±0.25pF	GRM1555C2A4R9CA01#
			5.0pF	±0.05pF	GRM1555C2A5R0WA01#
				±0.1pF	GRM1555C2A5R0BA01#
				±0.25pF	GRM1555C2A5R0CA01#
5.1pF	±0.05pF	GRM1555C2A5R1WA01#			

品名 # 表示包装规格代码。

GRM 系列
GJM 系列
GMA 系列
GMD 系列
GQM 系列
GRJ 系列
GR3 系列
KRM 系列
KR3 系列
LLA 系列
LLL 系列
LLM 系列
LLR 系列
警告 / 注意事項

GRM 系列温度补偿型品名列表

(→ ■ 1.0×0.5mm)

T 最大值	额定 电压	温度特 性代号	静电容量	公差	品名
0.55mm	100Vdc	C0G	5.1pF	±0.1pF	GRM1555C2A5R1BA01#
				±0.25pF	GRM1555C2A5R1CA01#
				±0.5pF	GRM1555C2A5R1DA01#
			5.2pF	±0.05pF	GRM1555C2A5R2WA01#
				±0.1pF	GRM1555C2A5R2BA01#
				±0.25pF	GRM1555C2A5R2CA01#
			5.3pF	±0.05pF	GRM1555C2A5R3WA01#
				±0.1pF	GRM1555C2A5R3BA01#
				±0.25pF	GRM1555C2A5R3CA01#
			5.4pF	±0.05pF	GRM1555C2A5R4WA01#
				±0.1pF	GRM1555C2A5R4BA01#
				±0.25pF	GRM1555C2A5R4CA01#
			5.5pF	±0.05pF	GRM1555C2A5R5WA01#
				±0.1pF	GRM1555C2A5R5BA01#
				±0.25pF	GRM1555C2A5R5CA01#
			5.6pF	±0.05pF	GRM1555C2A5R6WA01#
				±0.1pF	GRM1555C2A5R6BA01#
				±0.25pF	GRM1555C2A5R6CA01#
			5.7pF	±0.05pF	GRM1555C2A5R7WA01#
				±0.1pF	GRM1555C2A5R7BA01#
				±0.25pF	GRM1555C2A5R7CA01#
			5.8pF	±0.05pF	GRM1555C2A5R8WA01#
				±0.1pF	GRM1555C2A5R8BA01#
				±0.25pF	GRM1555C2A5R8CA01#
			5.9pF	±0.05pF	GRM1555C2A5R9WA01#
				±0.1pF	GRM1555C2A5R9BA01#
				±0.25pF	GRM1555C2A5R9CA01#
			6.0pF	±0.05pF	GRM1555C2A6R0WA01#
				±0.1pF	GRM1555C2A6R0BA01#
				±0.25pF	GRM1555C2A6R0CA01#
			6.1pF	±0.05pF	GRM1555C2A6R1WA01#
				±0.1pF	GRM1555C2A6R1BA01#
				±0.25pF	GRM1555C2A6R1CA01#
			6.2pF	±0.05pF	GRM1555C2A6R2WA01#
				±0.1pF	GRM1555C2A6R2BA01#
				±0.25pF	GRM1555C2A6R2CA01#
			6.3pF	±0.05pF	GRM1555C2A6R3WA01#
				±0.1pF	GRM1555C2A6R3BA01#
				±0.25pF	GRM1555C2A6R3CA01#
			6.4pF	±0.05pF	GRM1555C2A6R4WA01#
				±0.1pF	GRM1555C2A6R4BA01#
				±0.25pF	GRM1555C2A6R4CA01#

T 最大值	额定 电压	温度特 性代号	静电容量	公差	品名
0.55mm	100Vdc	C0G	6.4pF	±0.5pF	GRM1555C2A6R4DA01#
				±0.05pF	GRM1555C2A6R5WA01#
				±0.1pF	GRM1555C2A6R5BA01#
			6.5pF	±0.25pF	GRM1555C2A6R5CA01#
				±0.5pF	GRM1555C2A6R5DA01#
				6.6pF	±0.05pF
			±0.1pF		GRM1555C2A6R6BA01#
			±0.25pF		GRM1555C2A6R6CA01#
			6.7pF	±0.05pF	GRM1555C2A6R7WA01#
				±0.1pF	GRM1555C2A6R7BA01#
				±0.25pF	GRM1555C2A6R7CA01#
			6.8pF	±0.05pF	GRM1555C2A6R8WA01#
				±0.1pF	GRM1555C2A6R8BA01#
				±0.25pF	GRM1555C2A6R8CA01#
			6.9pF	±0.05pF	GRM1555C2A6R9WA01#
				±0.1pF	GRM1555C2A6R9BA01#
				±0.25pF	GRM1555C2A6R9CA01#
			7.0pF	±0.05pF	GRM1555C2A7R0WA01#
				±0.1pF	GRM1555C2A7R0BA01#
				±0.25pF	GRM1555C2A7R0CA01#
			7.1pF	±0.05pF	GRM1555C2A7R1WA01#
				±0.1pF	GRM1555C2A7R1BA01#
				±0.25pF	GRM1555C2A7R1CA01#
			7.2pF	±0.05pF	GRM1555C2A7R2WA01#
				±0.1pF	GRM1555C2A7R2BA01#
				±0.25pF	GRM1555C2A7R2CA01#
			7.3pF	±0.05pF	GRM1555C2A7R3WA01#
				±0.1pF	GRM1555C2A7R3BA01#
				±0.25pF	GRM1555C2A7R3CA01#
			7.4pF	±0.05pF	GRM1555C2A7R4WA01#
				±0.1pF	GRM1555C2A7R4BA01#
				±0.25pF	GRM1555C2A7R4CA01#
			7.5pF	±0.05pF	GRM1555C2A7R5WA01#
				±0.1pF	GRM1555C2A7R5BA01#
				±0.25pF	GRM1555C2A7R5CA01#
			7.6pF	±0.05pF	GRM1555C2A7R6WA01#
				±0.1pF	GRM1555C2A7R6BA01#
				±0.25pF	GRM1555C2A7R6CA01#
			7.7pF	±0.05pF	GRM1555C2A7R7WA01#
				±0.1pF	GRM1555C2A7R7BA01#
				±0.25pF	GRM1555C2A7R7CA01#
			7.8pF	±0.05pF	GRM1555C2A7R8WA01#
				±0.1pF	GRM1555C2A7R8BA01#
				±0.25pF	GRM1555C2A7R8CA01#

品名 # 表示包装规格代码。

GRM 系列
GJM 系列
GMA 系列
GMD 系列
GQM 系列
GRJ 系列
GR3 系列
KRM 系列
KR3 系列
LLA 系列
LLL 系列
LLM 系列
LLR 系列
警告/注意事项

GRM 系列温度补偿型品名列表

(→ ■ 1.0×0.5mm)

T 最大值	额定 电压	温度特 性代号	静电容量	公差	品名
0.55mm	100Vdc	C0G	7.8pF	±0.1pF	GRM1555C2A7R8BA01#
				±0.25pF	GRM1555C2A7R8CA01#
				±0.5pF	GRM1555C2A7R8DA01#
			7.9pF	±0.05pF	GRM1555C2A7R9WA01#
				±0.1pF	GRM1555C2A7R9BA01#
				±0.25pF	GRM1555C2A7R9CA01#
			8.0pF	±0.05pF	GRM1555C2A8R0WA01#
				±0.1pF	GRM1555C2A8R0BA01#
				±0.25pF	GRM1555C2A8R0CA01#
			8.1pF	±0.05pF	GRM1555C2A8R1WA01#
				±0.1pF	GRM1555C2A8R1BA01#
				±0.25pF	GRM1555C2A8R1CA01#
			8.2pF	±0.05pF	GRM1555C2A8R2WA01#
				±0.1pF	GRM1555C2A8R2BA01#
				±0.25pF	GRM1555C2A8R2CA01#
			8.3pF	±0.05pF	GRM1555C2A8R3WA01#
				±0.1pF	GRM1555C2A8R3BA01#
				±0.25pF	GRM1555C2A8R3CA01#
			8.4pF	±0.05pF	GRM1555C2A8R4WA01#
				±0.1pF	GRM1555C2A8R4BA01#
				±0.25pF	GRM1555C2A8R4CA01#
			8.5pF	±0.05pF	GRM1555C2A8R5WA01#
				±0.1pF	GRM1555C2A8R5BA01#
				±0.25pF	GRM1555C2A8R5CA01#
			8.6pF	±0.05pF	GRM1555C2A8R6WA01#
				±0.1pF	GRM1555C2A8R6BA01#
				±0.25pF	GRM1555C2A8R6CA01#
			8.7pF	±0.05pF	GRM1555C2A8R7WA01#
				±0.1pF	GRM1555C2A8R7BA01#
				±0.25pF	GRM1555C2A8R7CA01#
			8.8pF	±0.05pF	GRM1555C2A8R8WA01#
				±0.1pF	GRM1555C2A8R8BA01#
				±0.25pF	GRM1555C2A8R8CA01#
			8.9pF	±0.05pF	GRM1555C2A8R9WA01#
				±0.1pF	GRM1555C2A8R9BA01#
				±0.25pF	GRM1555C2A8R9CA01#
			9.0pF	±0.05pF	GRM1555C2A9R0WA01#
				±0.1pF	GRM1555C2A9R0BA01#
				±0.25pF	GRM1555C2A9R0CA01#
			9.1pF	±0.05pF	GRM1555C2A9R1WA01#
				±0.1pF	GRM1555C2A9R1BA01#
				±0.25pF	GRM1555C2A9R1CA01#

T 最大值	额定 电压	温度特 性代号	静电容量	公差	品名
0.55mm	100Vdc	C0G	9.1pF	±0.5pF	GRM1555C2A9R1DA01#
				±0.05pF	GRM1555C2A9R2WA01#
				±0.1pF	GRM1555C2A9R2BA01#
			9.2pF	±0.25pF	GRM1555C2A9R2CA01#
				±0.5pF	GRM1555C2A9R2DA01#
				9.3pF	±0.05pF
			±0.1pF		GRM1555C2A9R3BA01#
			±0.25pF		GRM1555C2A9R3CA01#
			9.4pF	±0.05pF	GRM1555C2A9R4WA01#
				±0.1pF	GRM1555C2A9R4BA01#
				±0.25pF	GRM1555C2A9R4CA01#
			9.5pF	±0.05pF	GRM1555C2A9R5WA01#
				±0.1pF	GRM1555C2A9R5BA01#
				±0.25pF	GRM1555C2A9R5CA01#
			9.6pF	±0.05pF	GRM1555C2A9R6WA01#
				±0.1pF	GRM1555C2A9R6BA01#
				±0.25pF	GRM1555C2A9R6CA01#
			9.7pF	±0.05pF	GRM1555C2A9R7WA01#
				±0.1pF	GRM1555C2A9R7BA01#
				±0.25pF	GRM1555C2A9R7CA01#
			9.8pF	±0.05pF	GRM1555C2A9R8WA01#
				±0.1pF	GRM1555C2A9R8BA01#
				±0.25pF	GRM1555C2A9R8CA01#
			9.9pF	±0.05pF	GRM1555C2A9R9WA01#
				±0.1pF	GRM1555C2A9R9BA01#
				±0.25pF	GRM1555C2A9R9CA01#
			10pF	±2%	GRM1555C2A100GA01#
				±5%	GRM1555C2A100JA01#
				12pF	±2%
			±5%		GRM1555C2A120JA01#
			15pF		±2%
				±5%	GRM1555C2A150JA01#
				18pF	±2%
			±5%		GRM1555C2A180JA01#
			22pF		±2%
				±5%	GRM1555C2A220JA01#
				27pF	±2%
			±5%		GRM1555C2A270JA01#
			33pF		±2%
				±5%	GRM1555C2A330JA01#
				39pF	±2%
			±5%		GRM1555C2A390JA01#
			47pF		±2%
				±5%	GRM1555C2A470JA01#
				56pF	±2%
			±5%		GRM1555C2A560JA01#
			68pF		±2%

品名 # 表示包装规格代码。

GRM 系列
GJM 系列
GMA 系列
GMD 系列
GQM 系列
GRJ 系列
GR3 系列
KRM 系列
KR3 系列
LLA 系列
LLL 系列
LLM 系列
LLR 系列
警告 / 注意事項

GRM 系列温度补偿型品名列表

(→ ■ 1.0×0.5mm)

T 最大值	额定 电压	温度特 性代号	静电容量	公差	品名
0.55mm	100Vdc	C0G	68pF	±5%	GRM1555C2A680JA01#
			82pF	±2%	GRM1555C2A820GA01#
				±5%	GRM1555C2A820JA01#
			100pF	±2%	GRM1555C2A101GA01#
				±5%	GRM1555C2A101JA01#
			CK	0.10pF	±0.05pF
		0.20pF		±0.05pF	GRM1554C2AR20WA01#
				±0.1pF	GRM1554C2AR20BA01#
		0.30pF		±0.05pF	GRM1554C2AR30WA01#
				±0.1pF	GRM1554C2AR30BA01#
		0.40pF		±0.05pF	GRM1554C2AR40WA01#
				±0.1pF	GRM1554C2AR40BA01#
		0.50pF		±0.05pF	GRM1554C2AR50WA01#
				±0.1pF	GRM1554C2AR50BA01#
		0.60pF		±0.05pF	GRM1554C2AR60WA01#
				±0.1pF	GRM1554C2AR60BA01#
		0.70pF		±0.05pF	GRM1554C2AR70WA01#
				±0.1pF	GRM1554C2AR70BA01#
		0.80pF		±0.05pF	GRM1554C2AR80WA01#
				±0.1pF	GRM1554C2AR80BA01#
		0.90pF		±0.05pF	GRM1554C2AR90WA01#
				±0.1pF	GRM1554C2AR90BA01#
		1.0pF		±0.05pF	GRM1554C2A1R0WA01#
				±0.1pF	GRM1554C2A1R0BA01#
				±0.25pF	GRM1554C2A1R0CA01#
		1.1pF		±0.05pF	GRM1554C2A1R1WA01#
				±0.1pF	GRM1554C2A1R1BA01#
				±0.25pF	GRM1554C2A1R1CA01#
		1.2pF		±0.05pF	GRM1554C2A1R2WA01#
				±0.1pF	GRM1554C2A1R2BA01#
				±0.25pF	GRM1554C2A1R2CA01#
		1.3pF		±0.05pF	GRM1554C2A1R3WA01#
				±0.1pF	GRM1554C2A1R3BA01#
				±0.25pF	GRM1554C2A1R3CA01#
		1.4pF		±0.05pF	GRM1554C2A1R4WA01#
				±0.1pF	GRM1554C2A1R4BA01#
				±0.25pF	GRM1554C2A1R4CA01#
		1.5pF		±0.05pF	GRM1554C2A1R5WA01#
				±0.1pF	GRM1554C2A1R5BA01#
				±0.25pF	GRM1554C2A1R5CA01#
		1.6pF		±0.05pF	GRM1554C2A1R6WA01#
			±0.1pF	GRM1554C2A1R6BA01#	
±0.25pF	GRM1554C2A1R6CA01#				
1.7pF	±0.05pF	GRM1554C2A1R7WA01#			
	±0.1pF	GRM1554C2A1R7BA01#			
	±0.25pF	GRM1554C2A1R7CA01#			
1.8pF	±0.05pF	GRM1554C2A1R8WA01#			
	±0.1pF	GRM1554C2A1R8BA01#			
	±0.25pF	GRM1554C2A1R8CA01#			
1.9pF	±0.05pF	GRM1554C2A1R9WA01#			
	±0.1pF	GRM1554C2A1R9BA01#			
	±0.25pF	GRM1554C2A1R9CA01#			
2.0pF	±0.05pF	GRM1554C2A2R0WA01#			
	±0.1pF	GRM1554C2A2R0BA01#			

T 最大值	额定 电压	温度特 性代号	静电容量	公差	品名
0.55mm	100Vdc	CK	2.0pF	±0.25pF	GRM1554C2A2R0CA01#
			CJ	2.1pF	±0.05pF
		2.2pF	±0.1pF	GRM1553C2A2R1BA01#	
			±0.25pF	GRM1553C2A2R1CA01#	
			±0.05pF	GRM1553C2A2R2WA01#	
		2.3pF	±0.1pF	GRM1553C2A2R2BA01#	
			±0.25pF	GRM1553C2A2R2CA01#	
			±0.05pF	GRM1553C2A2R3WA01#	
		2.4pF	±0.1pF	GRM1553C2A2R3BA01#	
			±0.25pF	GRM1553C2A2R3CA01#	
			±0.05pF	GRM1553C2A2R4WA01#	
		2.5pF	±0.1pF	GRM1553C2A2R4BA01#	
			±0.25pF	GRM1553C2A2R4CA01#	
			±0.05pF	GRM1553C2A2R5WA01#	
		2.6pF	±0.1pF	GRM1553C2A2R5BA01#	
			±0.25pF	GRM1553C2A2R5CA01#	
			±0.05pF	GRM1553C2A2R6WA01#	
		2.7pF	±0.1pF	GRM1553C2A2R6BA01#	
			±0.25pF	GRM1553C2A2R6CA01#	
			±0.05pF	GRM1553C2A2R7WA01#	
		2.8pF	±0.1pF	GRM1553C2A2R7BA01#	
			±0.25pF	GRM1553C2A2R7CA01#	
			±0.05pF	GRM1553C2A2R8WA01#	
		2.9pF	±0.1pF	GRM1553C2A2R8BA01#	
			±0.25pF	GRM1553C2A2R8CA01#	
			±0.05pF	GRM1553C2A2R9WA01#	
		3.0pF	±0.1pF	GRM1553C2A2R9BA01#	
			±0.25pF	GRM1553C2A2R9CA01#	
			±0.05pF	GRM1553C2A3R0WA01#	
		3.1pF	±0.1pF	GRM1553C2A3R0BA01#	
			±0.25pF	GRM1553C2A3R0CA01#	
			±0.05pF	GRM1553C2A3R1WA01#	
		3.2pF	±0.1pF	GRM1553C2A3R1BA01#	
			±0.25pF	GRM1553C2A3R1CA01#	
			±0.05pF	GRM1553C2A3R2WA01#	
		3.3pF	±0.1pF	GRM1553C2A3R2BA01#	
			±0.25pF	GRM1553C2A3R2CA01#	
			±0.05pF	GRM1553C2A3R3WA01#	
		3.4pF	±0.1pF	GRM1553C2A3R3BA01#	
			±0.25pF	GRM1553C2A3R3CA01#	
			±0.05pF	GRM1553C2A3R4WA01#	
		3.5pF	±0.1pF	GRM1553C2A3R4BA01#	
±0.25pF	GRM1553C2A3R4CA01#				
±0.05pF	GRM1553C2A3R5WA01#				
3.6pF	±0.1pF	GRM1553C2A3R5BA01#			
	±0.25pF	GRM1553C2A3R5CA01#			
	±0.05pF	GRM1553C2A3R6WA01#			
3.7pF	±0.1pF	GRM1553C2A3R6BA01#			
	±0.25pF	GRM1553C2A3R6CA01#			
	±0.05pF	GRM1553C2A3R7WA01#			
3.8pF	±0.1pF	GRM1553C2A3R7BA01#			
	±0.25pF	GRM1553C2A3R7CA01#			
	±0.05pF	GRM1553C2A3R8WA01#			
±0.1pF	GRM1553C2A3R8BA01#				

品名 # 表示包装规格代码。

GRM 系列
GJM 系列
GMA 系列
GMD 系列
GQM 系列
GRJ 系列
GR3 系列
KRM 系列
KR3 系列
LLA 系列
LLL 系列
LLM 系列
LLR 系列
警告/注意事项

GRM 系列温度补偿型品名列表

(→ ■ 1.0×0.5mm)

T 最大值	额定 电压	温度特 性代号	静电容量	公差	品名	
0.55mm	100Vdc	CJ	3.8pF	±0.25pF	GRM1553C2A3R8CA01#	
				±0.05pF	GRM1553C2A3R9WA01#	
				±0.1pF	GRM1553C2A3R9BA01#	
				±0.25pF	GRM1553C2A3R9CA01#	
			CH	4.0pF	±0.05pF	GRM1552C2A4R0WA01#
					±0.1pF	GRM1552C2A4R0BA01#
					±0.25pF	GRM1552C2A4R0CA01#
				4.1pF	±0.05pF	GRM1552C2A4R1WA01#
					±0.1pF	GRM1552C2A4R1BA01#
					±0.25pF	GRM1552C2A4R1CA01#
		4.2pF		±0.05pF	GRM1552C2A4R2WA01#	
				±0.1pF	GRM1552C2A4R2BA01#	
				±0.25pF	GRM1552C2A4R2CA01#	
		4.3pF		±0.05pF	GRM1552C2A4R3WA01#	
			±0.1pF	GRM1552C2A4R3BA01#		
			±0.25pF	GRM1552C2A4R3CA01#		
		4.4pF	±0.05pF	GRM1552C2A4R4WA01#		
			±0.1pF	GRM1552C2A4R4BA01#		
			±0.25pF	GRM1552C2A4R4CA01#		
		4.5pF	±0.05pF	GRM1552C2A4R5WA01#		
			±0.1pF	GRM1552C2A4R5BA01#		
			±0.25pF	GRM1552C2A4R5CA01#		
		4.6pF	±0.05pF	GRM1552C2A4R6WA01#		
			±0.1pF	GRM1552C2A4R6BA01#		
			±0.25pF	GRM1552C2A4R6CA01#		
		4.7pF	±0.05pF	GRM1552C2A4R7WA01#		
			±0.1pF	GRM1552C2A4R7BA01#		
			±0.25pF	GRM1552C2A4R7CA01#		
		4.8pF	±0.05pF	GRM1552C2A4R8WA01#		
			±0.1pF	GRM1552C2A4R8BA01#		
			±0.25pF	GRM1552C2A4R8CA01#		
		4.9pF	±0.05pF	GRM1552C2A4R9WA01#		
			±0.1pF	GRM1552C2A4R9BA01#		
			±0.25pF	GRM1552C2A4R9CA01#		
		5.0pF	±0.05pF	GRM1552C2A5R0WA01#		
			±0.1pF	GRM1552C2A5R0BA01#		
			±0.25pF	GRM1552C2A5R0CA01#		
		5.1pF	±0.05pF	GRM1552C2A5R1WA01#		
			±0.1pF	GRM1552C2A5R1BA01#		
			±0.25pF	GRM1552C2A5R1CA01#		
		5.2pF	±0.05pF	GRM1552C2A5R2WA01#		
			±0.1pF	GRM1552C2A5R2BA01#		
			±0.25pF	GRM1552C2A5R2CA01#		
		5.3pF	±0.05pF	GRM1552C2A5R3WA01#		
			±0.1pF	GRM1552C2A5R3BA01#		
			±0.25pF	GRM1552C2A5R3CA01#		
		5.4pF	±0.05pF	GRM1552C2A5R4WA01#		
			±0.1pF	GRM1552C2A5R4BA01#		
			±0.25pF	GRM1552C2A5R4CA01#		
		5.5pF	±0.05pF	GRM1552C2A5R5WA01#		
±0.1pF	GRM1552C2A5R5BA01#					
±0.25pF	GRM1552C2A5R5CA01#					

T 最大值	额定 电压	温度特 性代号	静电容量	公差	品名
0.55mm	100Vdc	CH	5.5pF	±0.1pF	GRM1552C2A5R5BA01#
				±0.25pF	GRM1552C2A5R5CA01#
				±0.5pF	GRM1552C2A5R5DA01#
			5.6pF	±0.05pF	GRM1552C2A5R6WA01#
				±0.1pF	GRM1552C2A5R6BA01#
				±0.25pF	GRM1552C2A5R6CA01#
			5.7pF	±0.05pF	GRM1552C2A5R7WA01#
				±0.1pF	GRM1552C2A5R7BA01#
				±0.25pF	GRM1552C2A5R7CA01#
			5.8pF	±0.05pF	GRM1552C2A5R8WA01#
				±0.1pF	GRM1552C2A5R8BA01#
				±0.25pF	GRM1552C2A5R8CA01#
			5.9pF	±0.05pF	GRM1552C2A5R9WA01#
				±0.1pF	GRM1552C2A5R9BA01#
				±0.25pF	GRM1552C2A5R9CA01#
			6.0pF	±0.05pF	GRM1552C2A6R0WA01#
				±0.1pF	GRM1552C2A6R0BA01#
				±0.25pF	GRM1552C2A6R0CA01#
			6.1pF	±0.05pF	GRM1552C2A6R1WA01#
				±0.1pF	GRM1552C2A6R1BA01#
				±0.25pF	GRM1552C2A6R1CA01#
			6.2pF	±0.05pF	GRM1552C2A6R2WA01#
				±0.1pF	GRM1552C2A6R2BA01#
				±0.25pF	GRM1552C2A6R2CA01#
			6.3pF	±0.05pF	GRM1552C2A6R3WA01#
				±0.1pF	GRM1552C2A6R3BA01#
				±0.25pF	GRM1552C2A6R3CA01#
			6.4pF	±0.05pF	GRM1552C2A6R4WA01#
				±0.1pF	GRM1552C2A6R4BA01#
				±0.25pF	GRM1552C2A6R4CA01#
			6.5pF	±0.05pF	GRM1552C2A6R5WA01#
				±0.1pF	GRM1552C2A6R5BA01#
				±0.25pF	GRM1552C2A6R5CA01#
			6.6pF	±0.05pF	GRM1552C2A6R6WA01#
				±0.1pF	GRM1552C2A6R6BA01#
				±0.25pF	GRM1552C2A6R6CA01#
			6.7pF	±0.05pF	GRM1552C2A6R7WA01#
				±0.1pF	GRM1552C2A6R7BA01#
				±0.25pF	GRM1552C2A6R7CA01#
			6.8pF	±0.05pF	GRM1552C2A6R8WA01#
				±0.1pF	GRM1552C2A6R8BA01#
				±0.25pF	GRM1552C2A6R8CA01#

品名 # 表示包装规格代码。

- GRM 系列
- GJM 系列
- GMA 系列
- GMD 系列
- GQM 系列
- GRJ 系列
- GR3 系列
- KRM 系列
- KR3 系列
- LJA 系列
- LLL 系列
- LJM 系列
- LLR 系列
- 警告 / 注意事項

GRM 系列温度补偿型品名列表

(→ ■ 1.0×0.5mm)

T 最大值	额定 电压	温度特 性代号	静电容量	公差	品名	
0.55mm	100Vdc	CH	6.8pF	±0.5pF	GRM1552C2A6R8DA01#	
				±0.05pF	GRM1552C2A6R9WA01#	
					±0.1pF	GRM1552C2A6R9BA01#
					±0.25pF	GRM1552C2A6R9CA01#
			±0.5pF	GRM1552C2A6R9DA01#		
				7.0pF	±0.05pF	GRM1552C2A7R0WA01#
					±0.1pF	GRM1552C2A7R0BA01#
					±0.25pF	GRM1552C2A7R0CA01#
			±0.5pF		GRM1552C2A7R0DA01#	
			7.1pF	±0.05pF	GRM1552C2A7R1WA01#	
				±0.1pF	GRM1552C2A7R1BA01#	
				±0.25pF	GRM1552C2A7R1CA01#	
				±0.5pF	GRM1552C2A7R1DA01#	
			7.2pF	±0.05pF	GRM1552C2A7R2WA01#	
				±0.1pF	GRM1552C2A7R2BA01#	
				±0.25pF	GRM1552C2A7R2CA01#	
				±0.5pF	GRM1552C2A7R2DA01#	
			7.3pF	±0.05pF	GRM1552C2A7R3WA01#	
				±0.1pF	GRM1552C2A7R3BA01#	
				±0.25pF	GRM1552C2A7R3CA01#	
				±0.5pF	GRM1552C2A7R3DA01#	
			7.4pF	±0.05pF	GRM1552C2A7R4WA01#	
				±0.1pF	GRM1552C2A7R4BA01#	
				±0.25pF	GRM1552C2A7R4CA01#	
				±0.5pF	GRM1552C2A7R4DA01#	
			7.5pF	±0.05pF	GRM1552C2A7R5WA01#	
				±0.1pF	GRM1552C2A7R5BA01#	
				±0.25pF	GRM1552C2A7R5CA01#	
				±0.5pF	GRM1552C2A7R5DA01#	
			7.6pF	±0.05pF	GRM1552C2A7R6WA01#	
				±0.1pF	GRM1552C2A7R6BA01#	
				±0.25pF	GRM1552C2A7R6CA01#	
				±0.5pF	GRM1552C2A7R6DA01#	
			7.7pF	±0.05pF	GRM1552C2A7R7WA01#	
				±0.1pF	GRM1552C2A7R7BA01#	
				±0.25pF	GRM1552C2A7R7CA01#	
				±0.5pF	GRM1552C2A7R7DA01#	
			7.8pF	±0.05pF	GRM1552C2A7R8WA01#	
				±0.1pF	GRM1552C2A7R8BA01#	
				±0.25pF	GRM1552C2A7R8CA01#	
				±0.5pF	GRM1552C2A7R8DA01#	
			7.9pF	±0.05pF	GRM1552C2A7R9WA01#	
				±0.1pF	GRM1552C2A7R9BA01#	
				±0.25pF	GRM1552C2A7R9CA01#	
				±0.5pF	GRM1552C2A7R9DA01#	
			8.0pF	±0.05pF	GRM1552C2A8R0WA01#	
				±0.1pF	GRM1552C2A8R0BA01#	
				±0.25pF	GRM1552C2A8R0CA01#	
				±0.5pF	GRM1552C2A8R0DA01#	
			8.1pF	±0.05pF	GRM1552C2A8R1WA01#	
				±0.1pF	GRM1552C2A8R1BA01#	
				±0.25pF	GRM1552C2A8R1CA01#	
±0.5pF	GRM1552C2A8R1DA01#					
8.2pF	±0.05pF	GRM1552C2A8R2WA01#				

T 最大值	额定 电压	温度特 性代号	静电容量	公差	品名	
0.55mm	100Vdc	CH	8.2pF	±0.1pF	GRM1552C2A8R2BA01#	
				±0.25pF	GRM1552C2A8R2CA01#	
				±0.5pF	GRM1552C2A8R2DA01#	
			8.3pF	±0.05pF	GRM1552C2A8R3WA01#	
				±0.1pF	GRM1552C2A8R3BA01#	
				±0.25pF	GRM1552C2A8R3CA01#	
			±0.5pF	GRM1552C2A8R3DA01#		
				8.4pF	±0.05pF	GRM1552C2A8R4WA01#
					±0.1pF	GRM1552C2A8R4BA01#
			±0.25pF		GRM1552C2A8R4CA01#	
			±0.5pF	GRM1552C2A8R4DA01#		
				8.5pF	±0.05pF	GRM1552C2A8R5WA01#
					±0.1pF	GRM1552C2A8R5BA01#
			±0.25pF		GRM1552C2A8R5CA01#	
			±0.5pF	GRM1552C2A8R5DA01#		
				8.6pF	±0.05pF	GRM1552C2A8R6WA01#
					±0.1pF	GRM1552C2A8R6BA01#
			±0.25pF		GRM1552C2A8R6CA01#	
			±0.5pF	GRM1552C2A8R6DA01#		
				8.7pF	±0.05pF	GRM1552C2A8R7WA01#
					±0.1pF	GRM1552C2A8R7BA01#
			±0.25pF		GRM1552C2A8R7CA01#	
			±0.5pF	GRM1552C2A8R7DA01#		
				8.8pF	±0.05pF	GRM1552C2A8R8WA01#
					±0.1pF	GRM1552C2A8R8BA01#
			±0.25pF		GRM1552C2A8R8CA01#	
			±0.5pF	GRM1552C2A8R8DA01#		
				8.9pF	±0.05pF	GRM1552C2A8R9WA01#
					±0.1pF	GRM1552C2A8R9BA01#
			±0.25pF		GRM1552C2A8R9CA01#	
			±0.5pF	GRM1552C2A8R9DA01#		
				9.0pF	±0.05pF	GRM1552C2A9R0WA01#
					±0.1pF	GRM1552C2A9R0BA01#
			±0.25pF		GRM1552C2A9R0CA01#	
			±0.5pF	GRM1552C2A9R0DA01#		
				9.1pF	±0.05pF	GRM1552C2A9R1WA01#
					±0.1pF	GRM1552C2A9R1BA01#
			±0.25pF		GRM1552C2A9R1CA01#	
			±0.5pF	GRM1552C2A9R1DA01#		
				9.2pF	±0.05pF	GRM1552C2A9R2WA01#
					±0.1pF	GRM1552C2A9R2BA01#
			±0.25pF		GRM1552C2A9R2CA01#	
			±0.5pF	GRM1552C2A9R2DA01#		
				9.3pF	±0.05pF	GRM1552C2A9R3WA01#
					±0.1pF	GRM1552C2A9R3BA01#
			±0.25pF		GRM1552C2A9R3CA01#	
			±0.5pF	GRM1552C2A9R3DA01#		
				9.4pF	±0.05pF	GRM1552C2A9R4WA01#
					±0.1pF	GRM1552C2A9R4BA01#
			±0.25pF		GRM1552C2A9R4CA01#	
			±0.5pF	GRM1552C2A9R4DA01#		
				9.5pF	±0.05pF	GRM1552C2A9R5WA01#
±0.1pF	GRM1552C2A9R5BA01#					
±0.25pF	GRM1552C2A9R5CA01#					

品名 # 表示包装规格代码。

GRM 系列
 GJM 系列
 GMA 系列
 GMD 系列
 GQM 系列
 GRJ 系列
 GR3 系列
 KRM 系列
 KR3 系列
 LLA 系列
 LLL 系列
 LLM 系列
 LLR 系列
 △警告/注意事项

GRM 系列温度补偿型品名列表

(→ ■ 1.0×0.5mm)

T 最大值	额定 电压	温度特 性代号	静电容量	公差	品名		
0.55mm	100Vdc	CH	9.5pF	±0.5pF	GRM1552C2A9R5DA01#		
				±0.05pF	GRM1552C2A9R6WA01#		
					±0.1pF	GRM1552C2A9R6BA01#	
					±0.25pF	GRM1552C2A9R6CA01#	
					±0.5pF	GRM1552C2A9R6DA01#	
			9.7pF	±0.05pF	GRM1552C2A9R7WA01#		
				±0.1pF	GRM1552C2A9R7BA01#		
				±0.25pF	GRM1552C2A9R7CA01#		
				±0.5pF	GRM1552C2A9R7DA01#		
				9.8pF	±0.05pF	GRM1552C2A9R8WA01#	
			±0.1pF		GRM1552C2A9R8BA01#		
			±0.25pF		GRM1552C2A9R8CA01#		
			±0.5pF		GRM1552C2A9R8DA01#		
			9.9pF		±0.05pF	GRM1552C2A9R9WA01#	
				±0.1pF	GRM1552C2A9R9BA01#		
				±0.25pF	GRM1552C2A9R9CA01#		
				±0.5pF	GRM1552C2A9R9DA01#		
				10pF	±2%	GRM1552C2A100GA01#	
			±5%		GRM1552C2A100JA01#		
			12pF	±2%	GRM1552C2A120GA01#		
				±5%	GRM1552C2A120JA01#		
			15pF	±2%	GRM1552C2A150GA01#		
				±5%	GRM1552C2A150JA01#		
			18pF	±2%	GRM1552C2A180GA01#		
				±5%	GRM1552C2A180JA01#		
			22pF	±2%	GRM1552C2A220GA01#		
				±5%	GRM1552C2A220JA01#		
			27pF	±2%	GRM1552C2A270GA01#		
				±5%	GRM1552C2A270JA01#		
			33pF	±2%	GRM1552C2A330GA01#		
				±5%	GRM1552C2A330JA01#		
			39pF	±2%	GRM1552C2A390GA01#		
				±5%	GRM1552C2A390JA01#		
			47pF	±2%	GRM1552C2A470GA01#		
				±5%	GRM1552C2A470JA01#		
			56pF	±2%	GRM1552C2A560GA01#		
				±5%	GRM1552C2A560JA01#		
			68pF	±2%	GRM1552C2A680GA01#		
				±5%	GRM1552C2A680JA01#		
			82pF	±2%	GRM1552C2A820GA01#		
				±5%	GRM1552C2A820JA01#		
			100pF	±2%	GRM1552C2A101GA01#		
				±5%	GRM1552C2A101JA01#		
			50Vdc	COG	0.10pF	±0.05pF	GRM1555C1HR10WA01#
						±0.05pF	GRM1555C1HR20WA01#
							±0.1pF
					0.30pF	±0.05pF	GRM1555C1HR30WA01#
						±0.1pF	GRM1555C1HR30BA01#
0.40pF	±0.05pF	GRM1555C1HR40WA01#					
	±0.1pF	GRM1555C1HR40BA01#					
0.50pF	±0.05pF	GRM1555C1HR50WA01#					
	±0.1pF	GRM1555C1HR50BA01#					
0.60pF	±0.05pF	GRM1555C1HR60WA01#					
	±0.1pF	GRM1555C1HR60BA01#					

T 最大值	额定 电压	温度特 性代号	静电容量	公差	品名
0.55mm	50Vdc	COG	0.70pF	±0.05pF	GRM1555C1HR70WA01#
				±0.1pF	GRM1555C1HR70BA01#
			0.80pF	±0.05pF	GRM1555C1HR80WA01#
				±0.1pF	GRM1555C1HR80BA01#
			0.90pF	±0.05pF	GRM1555C1HR90WA01#
				±0.1pF	GRM1555C1HR90BA01#
			1.0pF	±0.05pF	GRM1555C1H1R0WA01#
				±0.1pF	GRM1555C1H1R0BA01#
				±0.25pF	GRM1555C1H1R0CA01#
				1.1pF	±0.05pF
			±0.1pF		GRM1555C1H1R1BA01#
			±0.25pF		GRM1555C1H1R1CA01#
			1.2pF	±0.05pF	GRM1555C1H1R2WA01#
				±0.1pF	GRM1555C1H1R2BA01#
				±0.25pF	GRM1555C1H1R2CA01#
			1.3pF	±0.05pF	GRM1555C1H1R3WA01#
				±0.1pF	GRM1555C1H1R3BA01#
				±0.25pF	GRM1555C1H1R3CA01#
				1.4pF	±0.05pF
			±0.1pF		GRM1555C1H1R4BA01#
			±0.25pF		GRM1555C1H1R4CA01#
			1.5pF	±0.05pF	GRM1555C1H1R5WA01#
				±0.1pF	GRM1555C1H1R5BA01#
				±0.25pF	GRM1555C1H1R5CA01#
			1.6pF	±0.05pF	GRM1555C1H1R6WA01#
				±0.1pF	GRM1555C1H1R6BA01#
				±0.25pF	GRM1555C1H1R6CA01#
			1.7pF	±0.05pF	GRM1555C1H1R7WA01#
				±0.1pF	GRM1555C1H1R7BA01#
				±0.25pF	GRM1555C1H1R7CA01#
			1.8pF	±0.05pF	GRM1555C1H1R8WA01#
				±0.1pF	GRM1555C1H1R8BA01#
				±0.25pF	GRM1555C1H1R8CA01#
			1.9pF	±0.05pF	GRM1555C1H1R9WA01#
				±0.1pF	GRM1555C1H1R9BA01#
				±0.25pF	GRM1555C1H1R9CA01#
			2.0pF	±0.05pF	GRM1555C1H2R0WA01#
				±0.1pF	GRM1555C1H2R0BA01#
				±0.25pF	GRM1555C1H2R0CA01#
			2.1pF	±0.05pF	GRM1555C1H2R1WA01#
				±0.1pF	GRM1555C1H2R1BA01#
				±0.25pF	GRM1555C1H2R1CA01#
			2.2pF	±0.05pF	GRM1555C1H2R2WA01#
				±0.1pF	GRM1555C1H2R2BA01#
				±0.25pF	GRM1555C1H2R2CA01#
			2.3pF	±0.05pF	GRM1555C1H2R3WA01#
				±0.1pF	GRM1555C1H2R3BA01#
				±0.25pF	GRM1555C1H2R3CA01#
2.4pF	±0.05pF	GRM1555C1H2R4WA01#			
	±0.1pF	GRM1555C1H2R4BA01#			
	±0.25pF	GRM1555C1H2R4CA01#			
2.5pF	±0.05pF	GRM1555C1H2R5WA01#			
	±0.1pF	GRM1555C1H2R5BA01#			
	±0.25pF	GRM1555C1H2R5CA01#			

品名 # 表示包装规格代码。

GRM 系列
GJM 系列
GMA 系列
GMD 系列
GQM 系列
GRJ 系列
GR3 系列
KRM 系列
KR3 系列
LLA 系列
LLL 系列
LLM 系列
LLR 系列
警告 / 注意事項

GRM 系列温度补偿型品名列表

(→ ■ 1.0×0.5mm)

T 最大值	额定 电压	温度特 性代号	静电容量	公差	品名
0.55mm	50Vdc	C0G	2.6pF	±0.05pF	GRM1555C1H2R6WA01#
				±0.1pF	GRM1555C1H2R6BA01#
				±0.25pF	GRM1555C1H2R6CA01#
			2.7pF	±0.05pF	GRM1555C1H2R7WA01#
				±0.1pF	GRM1555C1H2R7BA01#
				±0.25pF	GRM1555C1H2R7CA01#
			2.8pF	±0.05pF	GRM1555C1H2R8WA01#
				±0.1pF	GRM1555C1H2R8BA01#
				±0.25pF	GRM1555C1H2R8CA01#
			2.9pF	±0.05pF	GRM1555C1H2R9WA01#
				±0.1pF	GRM1555C1H2R9BA01#
				±0.25pF	GRM1555C1H2R9CA01#
			3.0pF	±0.05pF	GRM1555C1H3R0WA01#
				±0.1pF	GRM1555C1H3R0BA01#
				±0.25pF	GRM1555C1H3R0CA01#
			3.1pF	±0.05pF	GRM1555C1H3R1WA01#
				±0.1pF	GRM1555C1H3R1BA01#
				±0.25pF	GRM1555C1H3R1CA01#
			3.2pF	±0.05pF	GRM1555C1H3R2WA01#
				±0.1pF	GRM1555C1H3R2BA01#
				±0.25pF	GRM1555C1H3R2CA01#
			3.3pF	±0.05pF	GRM1555C1H3R3WA01#
				±0.1pF	GRM1555C1H3R3BA01#
				±0.25pF	GRM1555C1H3R3CA01#
			3.4pF	±0.05pF	GRM1555C1H3R4WA01#
				±0.1pF	GRM1555C1H3R4BA01#
				±0.25pF	GRM1555C1H3R4CA01#
			3.5pF	±0.05pF	GRM1555C1H3R5WA01#
				±0.1pF	GRM1555C1H3R5BA01#
				±0.25pF	GRM1555C1H3R5CA01#
			3.6pF	±0.05pF	GRM1555C1H3R6WA01#
				±0.1pF	GRM1555C1H3R6BA01#
				±0.25pF	GRM1555C1H3R6CA01#
			3.7pF	±0.05pF	GRM1555C1H3R7WA01#
				±0.1pF	GRM1555C1H3R7BA01#
				±0.25pF	GRM1555C1H3R7CA01#
			3.8pF	±0.05pF	GRM1555C1H3R8WA01#
				±0.1pF	GRM1555C1H3R8BA01#
				±0.25pF	GRM1555C1H3R8CA01#
			3.9pF	±0.05pF	GRM1555C1H3R9WA01#
				±0.1pF	GRM1555C1H3R9BA01#
				±0.25pF	GRM1555C1H3R9CA01#
			4.0pF	±0.05pF	GRM1555C1H4R0WA01#
				±0.1pF	GRM1555C1H4R0BA01#
				±0.25pF	GRM1555C1H4R0CA01#
			4.1pF	±0.05pF	GRM1555C1H4R1WA01#
				±0.1pF	GRM1555C1H4R1BA01#
				±0.25pF	GRM1555C1H4R1CA01#
4.2pF	±0.05pF	GRM1555C1H4R2WA01#			
	±0.1pF	GRM1555C1H4R2BA01#			
	±0.25pF	GRM1555C1H4R2CA01#			
4.3pF	±0.05pF	GRM1555C1H4R3WA01#			
	±0.1pF	GRM1555C1H4R3BA01#			
	±0.25pF	GRM1555C1H4R3CA01#			

T 最大值	额定 电压	温度特 性代号	静电容量	公差	品名
0.55mm	50Vdc	C0G	4.4pF	±0.05pF	GRM1555C1H4R4WA01#
				±0.1pF	GRM1555C1H4R4BA01#
				±0.25pF	GRM1555C1H4R4CA01#
			4.5pF	±0.05pF	GRM1555C1H4R5WA01#
				±0.1pF	GRM1555C1H4R5BA01#
				±0.25pF	GRM1555C1H4R5CA01#
			4.6pF	±0.05pF	GRM1555C1H4R6WA01#
				±0.1pF	GRM1555C1H4R6BA01#
				±0.25pF	GRM1555C1H4R6CA01#
			4.7pF	±0.05pF	GRM1555C1H4R7WA01#
				±0.1pF	GRM1555C1H4R7BA01#
				±0.25pF	GRM1555C1H4R7CA01#
			4.8pF	±0.05pF	GRM1555C1H4R8WA01#
				±0.1pF	GRM1555C1H4R8BA01#
				±0.25pF	GRM1555C1H4R8CA01#
			4.9pF	±0.05pF	GRM1555C1H4R9WA01#
				±0.1pF	GRM1555C1H4R9BA01#
				±0.25pF	GRM1555C1H4R9CA01#
			5.0pF	±0.05pF	GRM1555C1H5R0WA01#
				±0.1pF	GRM1555C1H5R0BA01#
				±0.25pF	GRM1555C1H5R0CA01#
			5.1pF	±0.05pF	GRM1555C1H5R1WA01#
				±0.1pF	GRM1555C1H5R1BA01#
				±0.25pF	GRM1555C1H5R1CA01#
			5.2pF	±0.05pF	GRM1555C1H5R2WA01#
				±0.1pF	GRM1555C1H5R2BA01#
				±0.25pF	GRM1555C1H5R2CA01#
			5.3pF	±0.05pF	GRM1555C1H5R3WA01#
				±0.1pF	GRM1555C1H5R3BA01#
				±0.25pF	GRM1555C1H5R3CA01#
			5.4pF	±0.05pF	GRM1555C1H5R4WA01#
				±0.1pF	GRM1555C1H5R4BA01#
				±0.25pF	GRM1555C1H5R4CA01#
			5.5pF	±0.05pF	GRM1555C1H5R5WA01#
				±0.1pF	GRM1555C1H5R5BA01#
				±0.25pF	GRM1555C1H5R5CA01#
			5.6pF	±0.05pF	GRM1555C1H5R6WA01#
				±0.1pF	GRM1555C1H5R6BA01#
				±0.25pF	GRM1555C1H5R6CA01#
			5.7pF	±0.05pF	GRM1555C1H5R7WA01#
				±0.1pF	GRM1555C1H5R7BA01#
				±0.25pF	GRM1555C1H5R7CA01#
			5.8pF	±0.05pF	GRM1555C1H5R8WA01#
				±0.1pF	GRM1555C1H5R8BA01#
				±0.25pF	GRM1555C1H5R8CA01#
			5.9pF	±0.05pF	GRM1555C1H5R9WA01#
				±0.1pF	GRM1555C1H5R9BA01#
				±0.25pF	GRM1555C1H5R9CA01#

品名 # 表示包装规格代码。

GRM 系列
GJM 系列
GMA 系列
GMD 系列
GQM 系列
GRJ 系列
GR3 系列
KRM 系列
KR3 系列
LLA 系列
LLM 系列
LLR 系列
警告/注意事项

GRM 系列温度补偿型品名列表

(→ ■ 1.0×0.5mm)

T 最大值	额定 电压	温度特 性代号	静电容量	公差	品名
0.55mm	50Vdc	COG	5.9pF	±0.1pF	GRM1555C1H5R9BA01#
				±0.25pF	GRM1555C1H5R9CA01#
				±0.5pF	GRM1555C1H5R9DA01#
			6.0pF	±0.05pF	GRM1555C1H6R0WA01#
				±0.1pF	GRM1555C1H6R0BA01#
				±0.25pF	GRM1555C1H6R0CA01#
			6.1pF	±0.05pF	GRM1555C1H6R1WA01#
				±0.1pF	GRM1555C1H6R1BA01#
				±0.25pF	GRM1555C1H6R1CA01#
			6.2pF	±0.05pF	GRM1555C1H6R2WA01#
				±0.1pF	GRM1555C1H6R2BA01#
				±0.25pF	GRM1555C1H6R2CA01#
			6.3pF	±0.05pF	GRM1555C1H6R3WA01#
				±0.1pF	GRM1555C1H6R3BA01#
				±0.25pF	GRM1555C1H6R3CA01#
			6.4pF	±0.05pF	GRM1555C1H6R4WA01#
				±0.1pF	GRM1555C1H6R4BA01#
				±0.25pF	GRM1555C1H6R4CA01#
			6.5pF	±0.05pF	GRM1555C1H6R5WA01#
				±0.1pF	GRM1555C1H6R5BA01#
				±0.25pF	GRM1555C1H6R5CA01#
			6.6pF	±0.05pF	GRM1555C1H6R6WA01#
				±0.1pF	GRM1555C1H6R6BA01#
				±0.25pF	GRM1555C1H6R6CA01#
			6.7pF	±0.05pF	GRM1555C1H6R7WA01#
				±0.1pF	GRM1555C1H6R7BA01#
				±0.25pF	GRM1555C1H6R7CA01#
			6.8pF	±0.05pF	GRM1555C1H6R8WA01#
				±0.1pF	GRM1555C1H6R8BA01#
				±0.25pF	GRM1555C1H6R8CA01#
			6.9pF	±0.05pF	GRM1555C1H6R9WA01#
				±0.1pF	GRM1555C1H6R9BA01#
				±0.25pF	GRM1555C1H6R9CA01#
			7.0pF	±0.05pF	GRM1555C1H7R0WA01#
				±0.1pF	GRM1555C1H7R0BA01#
				±0.25pF	GRM1555C1H7R0CA01#
			7.1pF	±0.05pF	GRM1555C1H7R1WA01#
				±0.1pF	GRM1555C1H7R1BA01#
				±0.25pF	GRM1555C1H7R1CA01#
			7.2pF	±0.05pF	GRM1555C1H7R2WA01#
				±0.1pF	GRM1555C1H7R2BA01#
				±0.25pF	GRM1555C1H7R2CA01#

T 最大值	额定 电压	温度特 性代号	静电容量	公差	品名
0.55mm	50Vdc	COG	7.2pF	±0.5pF	GRM1555C1H7R2DA01#
				±0.05pF	GRM1555C1H7R3WA01#
				±0.1pF	GRM1555C1H7R3BA01#
			7.3pF	±0.25pF	GRM1555C1H7R3CA01#
				±0.5pF	GRM1555C1H7R3DA01#
				7.4pF	±0.05pF
			±0.1pF		GRM1555C1H7R4BA01#
			±0.25pF		GRM1555C1H7R4CA01#
			7.5pF	±0.05pF	GRM1555C1H7R5WA01#
				±0.1pF	GRM1555C1H7R5BA01#
				±0.25pF	GRM1555C1H7R5CA01#
			7.6pF	±0.05pF	GRM1555C1H7R6WA01#
				±0.1pF	GRM1555C1H7R6BA01#
				±0.25pF	GRM1555C1H7R6CA01#
			7.7pF	±0.05pF	GRM1555C1H7R7WA01#
				±0.1pF	GRM1555C1H7R7BA01#
				±0.25pF	GRM1555C1H7R7CA01#
			7.8pF	±0.05pF	GRM1555C1H7R8WA01#
				±0.1pF	GRM1555C1H7R8BA01#
				±0.25pF	GRM1555C1H7R8CA01#
			7.9pF	±0.05pF	GRM1555C1H7R9WA01#
				±0.1pF	GRM1555C1H7R9BA01#
				±0.25pF	GRM1555C1H7R9CA01#
			8.0pF	±0.05pF	GRM1555C1H8R0WA01#
				±0.1pF	GRM1555C1H8R0BA01#
				±0.25pF	GRM1555C1H8R0CA01#
			8.1pF	±0.05pF	GRM1555C1H8R1WA01#
				±0.1pF	GRM1555C1H8R1BA01#
				±0.25pF	GRM1555C1H8R1CA01#
			8.2pF	±0.05pF	GRM1555C1H8R2WA01#
				±0.1pF	GRM1555C1H8R2BA01#
				±0.25pF	GRM1555C1H8R2CA01#
			8.3pF	±0.05pF	GRM1555C1H8R3WA01#
				±0.1pF	GRM1555C1H8R3BA01#
				±0.25pF	GRM1555C1H8R3CA01#
			8.4pF	±0.05pF	GRM1555C1H8R4WA01#
				±0.1pF	GRM1555C1H8R4BA01#
				±0.25pF	GRM1555C1H8R4CA01#
			8.5pF	±0.05pF	GRM1555C1H8R5WA01#
				±0.1pF	GRM1555C1H8R5BA01#
				±0.25pF	GRM1555C1H8R5CA01#
			8.6pF	±0.05pF	GRM1555C1H8R6WA01#
				±0.1pF	GRM1555C1H8R6BA01#
				±0.25pF	GRM1555C1H8R6CA01#

品名 # 表示包装规格代码。

- GRM 系列
- GJM 系列
- GMA 系列
- GMD 系列
- GQM 系列
- GRJ 系列
- GR3 系列
- KRM 系列
- KR3 系列
- LJA 系列
- LLL 系列
- LLM 系列
- LLR 系列
- 警告 / 注意事項

GRM 系列温度补偿型品名列表

(→ ■ 1.0×0.5mm)

T 最大值	额定 电压	温度特 性代号	静电容量	公差	品名
0.55mm	50Vdc	C0G	8.6pF	±0.1pF	GRM1555C1H8R6BA01#
				±0.25pF	GRM1555C1H8R6CA01#
				±0.5pF	GRM1555C1H8R6DA01#
			8.7pF	±0.05pF	GRM1555C1H8R7WA01#
				±0.1pF	GRM1555C1H8R7BA01#
				±0.25pF	GRM1555C1H8R7CA01#
			8.8pF	±0.05pF	GRM1555C1H8R8WA01#
				±0.1pF	GRM1555C1H8R8BA01#
				±0.25pF	GRM1555C1H8R8CA01#
			8.9pF	±0.05pF	GRM1555C1H8R9WA01#
				±0.1pF	GRM1555C1H8R9BA01#
				±0.25pF	GRM1555C1H8R9CA01#
			9.0pF	±0.05pF	GRM1555C1H9R0WA01#
				±0.1pF	GRM1555C1H9R0BA01#
				±0.25pF	GRM1555C1H9R0CA01#
			9.1pF	±0.05pF	GRM1555C1H9R1WA01#
				±0.1pF	GRM1555C1H9R1BA01#
				±0.25pF	GRM1555C1H9R1CA01#
			9.2pF	±0.05pF	GRM1555C1H9R2WA01#
				±0.1pF	GRM1555C1H9R2BA01#
				±0.25pF	GRM1555C1H9R2CA01#
			9.3pF	±0.05pF	GRM1555C1H9R3WA01#
				±0.1pF	GRM1555C1H9R3BA01#
				±0.25pF	GRM1555C1H9R3CA01#
			9.4pF	±0.05pF	GRM1555C1H9R4WA01#
				±0.1pF	GRM1555C1H9R4BA01#
				±0.25pF	GRM1555C1H9R4CA01#
			9.5pF	±0.05pF	GRM1555C1H9R5WA01#
				±0.1pF	GRM1555C1H9R5BA01#
				±0.25pF	GRM1555C1H9R5CA01#
			9.6pF	±0.05pF	GRM1555C1H9R6WA01#
				±0.1pF	GRM1555C1H9R6BA01#
				±0.25pF	GRM1555C1H9R6CA01#
			9.7pF	±0.05pF	GRM1555C1H9R7WA01#
				±0.1pF	GRM1555C1H9R7BA01#
				±0.25pF	GRM1555C1H9R7CA01#
			9.8pF	±0.05pF	GRM1555C1H9R8WA01#
				±0.1pF	GRM1555C1H9R8BA01#
				±0.25pF	GRM1555C1H9R8CA01#
			9.9pF	±0.05pF	GRM1555C1H9R9WA01#
				±0.1pF	GRM1555C1H9R9BA01#
				±0.25pF	GRM1555C1H9R9CA01#

T 最大值	额定 电压	温度特 性代号	静电容量	公差	品名
0.55mm	50Vdc	C0G	9.9pF	±0.5pF	GRM1555C1H9R9DA01#
				±2%	GRM1555C1H100GA01#
			10pF	±5%	GRM1555C1H100JA01#
				±2%	GRM1555C1H120GA01#
			12pF	±5%	GRM1555C1H120JA01#
				±2%	GRM1555C1H150GA01#
			15pF	±5%	GRM1555C1H150JA01#
				±2%	GRM1555C1H180GA01#
			18pF	±5%	GRM1555C1H180JA01#
				±2%	GRM1555C1H220GA01#
			22pF	±5%	GRM1555C1H220JA01#
				±2%	GRM1555C1H270GA01#
			27pF	±5%	GRM1555C1H270JA01#
				±2%	GRM1555C1H330GA01#
			33pF	±5%	GRM1555C1H330JA01#
				±2%	GRM1555C1H390GA01#
			39pF	±5%	GRM1555C1H390JA01#
				±2%	GRM1555C1H470GA01#
			47pF	±5%	GRM1555C1H470JA01#
				±2%	GRM1555C1H560GA01#
			56pF	±5%	GRM1555C1H560JA01#
				±2%	GRM1555C1H680GA01#
			68pF	±5%	GRM1555C1H680JA01#
				±2%	GRM1555C1H820GA01#
			82pF	±5%	GRM1555C1H820JA01#
				±2%	GRM1555C1H101GA01#
			100pF	±5%	GRM1555C1H101JA01#
				±2%	GRM1555C1H121GA01#
			120pF	±5%	GRM1555C1H121JA01#
				±2%	GRM1555C1H151GA01#
			150pF	±5%	GRM1555C1H151JA01#
				±2%	GRM1555C1H181GA01#
			180pF	±5%	GRM1555C1H181JA01#
				±2%	GRM1555C1H221GA01#
			220pF	±5%	GRM1555C1H221JA01#
				±2%	GRM1555C1H271GA01#
			270pF	±5%	GRM1555C1H271JA01#
				±2%	GRM1555C1H331GA01#
			330pF	±5%	GRM1555C1H331JA01#
				±2%	GRM1555C1H391GA01#
			390pF	±5%	GRM1555C1H391JA01#
				±2%	GRM1555C1H471GA01#
			470pF	±5%	GRM1555C1H471JA01#
				±2%	GRM1555C1H561GA01#
			560pF	±5%	GRM1555C1H561JA01#
±2%	GRM1555C1H681GA01#				
680pF	±5%	GRM1555C1H681JA01#			
	±2%	GRM1555C1H821GA01#			
820pF	±5%	GRM1555C1H821JA01#			
	±2%	GRM1555C1H102GA01#			
1000pF	±5%	GRM1555C1H102JA01#			
	CK	±0.05pF	GRM1554C1HR10WA01#		
0.10pF	±0.05pF	GRM1554C1HR20WA01#			
	±0.1pF	GRM1554C1HR20BA01#			

品名 # 表示包装规格代码。

GRM 系列
GJM 系列
GMA 系列
GMD 系列
GQM 系列
GRJ 系列
GR3 系列
KRM 系列
KR3 系列
LLA 系列
LLL 系列
LLM 系列
LLR 系列
警告/注意事项

GRM 系列温度补偿型品名列表

(→ ■ 1.0×0.5mm)

T 最大值	额定 电压	温度特 性代号	静电容量	公差	品名
0.55mm	50Vdc	CK	0.30pF	±0.05pF	GRM1554C1HR30WA01#
				±0.1pF	GRM1554C1HR30BA01#
				±0.25pF	GRM1554C1HR30CA01#
			0.40pF	±0.05pF	GRM1554C1HR40WA01#
				±0.1pF	GRM1554C1HR40BA01#
				±0.25pF	GRM1554C1HR40CA01#
			0.50pF	±0.05pF	GRM1554C1HR50WA01#
				±0.1pF	GRM1554C1HR50BA01#
			0.60pF	±0.05pF	GRM1554C1HR60WA01#
				±0.1pF	GRM1554C1HR60BA01#
			0.70pF	±0.05pF	GRM1554C1HR70WA01#
				±0.1pF	GRM1554C1HR70BA01#
			0.80pF	±0.05pF	GRM1554C1HR80WA01#
				±0.1pF	GRM1554C1HR80BA01#
			0.90pF	±0.05pF	GRM1554C1HR90WA01#
				±0.1pF	GRM1554C1HR90BA01#
			1.0pF	±0.05pF	GRM1554C1H1R0WA01#
				±0.1pF	GRM1554C1H1R0BA01#
				±0.25pF	GRM1554C1H1R0CA01#
			1.1pF	±0.05pF	GRM1554C1H1R1WA01#
				±0.1pF	GRM1554C1H1R1BA01#
				±0.25pF	GRM1554C1H1R1CA01#
			1.2pF	±0.05pF	GRM1554C1H1R2WA01#
				±0.1pF	GRM1554C1H1R2BA01#
				±0.25pF	GRM1554C1H1R2CA01#
			1.3pF	±0.05pF	GRM1554C1H1R3WA01#
				±0.1pF	GRM1554C1H1R3BA01#
				±0.25pF	GRM1554C1H1R3CA01#
			1.4pF	±0.05pF	GRM1554C1H1R4WA01#
				±0.1pF	GRM1554C1H1R4BA01#
				±0.25pF	GRM1554C1H1R4CA01#
			1.5pF	±0.05pF	GRM1554C1H1R5WA01#
				±0.1pF	GRM1554C1H1R5BA01#
				±0.25pF	GRM1554C1H1R5CA01#
			1.6pF	±0.05pF	GRM1554C1H1R6WA01#
				±0.1pF	GRM1554C1H1R6BA01#
		±0.25pF		GRM1554C1H1R6CA01#	
		1.7pF	±0.05pF	GRM1554C1H1R7WA01#	
			±0.1pF	GRM1554C1H1R7BA01#	
			±0.25pF	GRM1554C1H1R7CA01#	
		1.8pF	±0.05pF	GRM1554C1H1R8WA01#	
			±0.1pF	GRM1554C1H1R8BA01#	
			±0.25pF	GRM1554C1H1R8CA01#	
		1.9pF	±0.05pF	GRM1554C1H1R9WA01#	
			±0.1pF	GRM1554C1H1R9BA01#	
			±0.25pF	GRM1554C1H1R9CA01#	
		2.0pF	±0.05pF	GRM1554C1H2R0WA01#	
			±0.1pF	GRM1554C1H2R0BA01#	
±0.25pF	GRM1554C1H2R0CA01#				
CJ	2.1pF	±0.05pF	GRM1553C1H2R1WA01#		
		±0.1pF	GRM1553C1H2R1BA01#		
		±0.25pF	GRM1553C1H2R1CA01#		
	2.2pF	±0.05pF	GRM1553C1H2R2WA01#		
		±0.1pF	GRM1553C1H2R2BA01#		
		±0.25pF	GRM1553C1H2R2CA01#		
	2.3pF	±0.05pF	GRM1553C1H2R3WA01#		

T 最大值	额定 电压	温度特 性代号	静电容量	公差	品名
0.55mm	50Vdc	CJ	2.3pF	±0.1pF	GRM1553C1H2R3BA01#
				±0.25pF	GRM1553C1H2R3CA01#
				±0.5pF	GRM1553C1H2R3WA01#
			2.4pF	±0.05pF	GRM1553C1H2R4WA01#
				±0.1pF	GRM1553C1H2R4BA01#
				±0.25pF	GRM1553C1H2R4CA01#
			2.5pF	±0.05pF	GRM1553C1H2R5WA01#
				±0.1pF	GRM1553C1H2R5BA01#
				±0.25pF	GRM1553C1H2R5CA01#
			2.6pF	±0.05pF	GRM1553C1H2R6WA01#
				±0.1pF	GRM1553C1H2R6BA01#
				±0.25pF	GRM1553C1H2R6CA01#
			2.7pF	±0.05pF	GRM1553C1H2R7WA01#
				±0.1pF	GRM1553C1H2R7BA01#
				±0.25pF	GRM1553C1H2R7CA01#
			2.8pF	±0.05pF	GRM1553C1H2R8WA01#
				±0.1pF	GRM1553C1H2R8BA01#
				±0.25pF	GRM1553C1H2R8CA01#
			2.9pF	±0.05pF	GRM1553C1H2R9WA01#
				±0.1pF	GRM1553C1H2R9BA01#
				±0.25pF	GRM1553C1H2R9CA01#
			3.0pF	±0.05pF	GRM1553C1H3R0WA01#
				±0.1pF	GRM1553C1H3R0BA01#
				±0.25pF	GRM1553C1H3R0CA01#
			3.1pF	±0.05pF	GRM1553C1H3R1WA01#
				±0.1pF	GRM1553C1H3R1BA01#
				±0.25pF	GRM1553C1H3R1CA01#
			3.2pF	±0.05pF	GRM1553C1H3R2WA01#
				±0.1pF	GRM1553C1H3R2BA01#
				±0.25pF	GRM1553C1H3R2CA01#
			3.3pF	±0.05pF	GRM1553C1H3R3WA01#
				±0.1pF	GRM1553C1H3R3BA01#
				±0.25pF	GRM1553C1H3R3CA01#
			3.4pF	±0.05pF	GRM1553C1H3R4WA01#
				±0.1pF	GRM1553C1H3R4BA01#
				±0.25pF	GRM1553C1H3R4CA01#
		3.5pF	±0.05pF	GRM1553C1H3R5WA01#	
			±0.1pF	GRM1553C1H3R5BA01#	
			±0.25pF	GRM1553C1H3R5CA01#	
		3.6pF	±0.05pF	GRM1553C1H3R6WA01#	
			±0.1pF	GRM1553C1H3R6BA01#	
			±0.25pF	GRM1553C1H3R6CA01#	
		3.7pF	±0.05pF	GRM1553C1H3R7WA01#	
			±0.1pF	GRM1553C1H3R7BA01#	
			±0.25pF	GRM1553C1H3R7CA01#	
		3.8pF	±0.05pF	GRM1553C1H3R8WA01#	
			±0.1pF	GRM1553C1H3R8BA01#	
			±0.25pF	GRM1553C1H3R8CA01#	
3.9pF	±0.05pF	GRM1553C1H3R9WA01#			
	±0.1pF	GRM1553C1H3R9BA01#			
	±0.25pF	GRM1553C1H3R9CA01#			
CH	4.0pF	±0.05pF	GRM1552C1H4R0WA01#		
		±0.1pF	GRM1552C1H4R0BA01#		
		±0.25pF	GRM1552C1H4R0CA01#		
4.1pF	±0.05pF	GRM1552C1H4R1WA01#			

品名 # 表示包装规格代码。

GRM 系列
GJM 系列
GMA 系列
GMD 系列
GQM 系列
GRJ 系列
GR3 系列
KRM 系列
KR3 系列
LLA 系列
LLL 系列
LLM 系列
LLR 系列
警告 / 注意事項

GRM 系列温度补偿型品名列表

(→ ■ 1.0×0.5mm)

T 最大值	额定 电压	温度特 性代号	静电容量	公差	品名
0.55mm	50Vdc	CH	4.1pF	±0.1pF	GRM1552C1H4R1BA01#
				±0.25pF	GRM1552C1H4R1CA01#
				±0.5pF	GRM1552C1H4R1DA01#
			4.2pF	±0.05pF	GRM1552C1H4R2WA01#
				±0.1pF	GRM1552C1H4R2BA01#
				±0.25pF	GRM1552C1H4R2CA01#
			4.3pF	±0.05pF	GRM1552C1H4R3WA01#
				±0.1pF	GRM1552C1H4R3BA01#
				±0.25pF	GRM1552C1H4R3CA01#
			4.4pF	±0.05pF	GRM1552C1H4R4WA01#
				±0.1pF	GRM1552C1H4R4BA01#
				±0.25pF	GRM1552C1H4R4CA01#
			4.5pF	±0.05pF	GRM1552C1H4R5WA01#
				±0.1pF	GRM1552C1H4R5BA01#
				±0.25pF	GRM1552C1H4R5CA01#
			4.6pF	±0.05pF	GRM1552C1H4R6WA01#
				±0.1pF	GRM1552C1H4R6BA01#
				±0.25pF	GRM1552C1H4R6CA01#
			4.7pF	±0.05pF	GRM1552C1H4R7WA01#
				±0.1pF	GRM1552C1H4R7BA01#
				±0.25pF	GRM1552C1H4R7CA01#
			4.8pF	±0.05pF	GRM1552C1H4R8WA01#
				±0.1pF	GRM1552C1H4R8BA01#
				±0.25pF	GRM1552C1H4R8CA01#
			4.9pF	±0.05pF	GRM1552C1H4R9WA01#
				±0.1pF	GRM1552C1H4R9BA01#
				±0.25pF	GRM1552C1H4R9CA01#
			5.0pF	±0.05pF	GRM1552C1H5R0WA01#
				±0.1pF	GRM1552C1H5R0BA01#
				±0.25pF	GRM1552C1H5R0CA01#
			5.1pF	±0.05pF	GRM1552C1H5R1WA01#
				±0.1pF	GRM1552C1H5R1BA01#
				±0.25pF	GRM1552C1H5R1CA01#
				±0.5pF	GRM1552C1H5R1DA01#
			5.2pF	±0.05pF	GRM1552C1H5R2WA01#
				±0.1pF	GRM1552C1H5R2BA01#
				±0.25pF	GRM1552C1H5R2CA01#
				±0.5pF	GRM1552C1H5R2DA01#
			5.3pF	±0.05pF	GRM1552C1H5R3WA01#
				±0.1pF	GRM1552C1H5R3BA01#
				±0.25pF	GRM1552C1H5R3CA01#
				±0.5pF	GRM1552C1H5R3DA01#
			5.4pF	±0.05pF	GRM1552C1H5R4WA01#
				±0.1pF	GRM1552C1H5R4BA01#
				±0.25pF	GRM1552C1H5R4CA01#
				±0.5pF	GRM1552C1H5R4DA01#
			5.5pF	±0.05pF	GRM1552C1H5R5WA01#
				±0.1pF	GRM1552C1H5R5BA01#
				±0.25pF	GRM1552C1H5R5CA01#
				±0.5pF	GRM1552C1H5R5DA01#
			5.6pF	±0.05pF	GRM1552C1H5R6WA01#
				±0.1pF	GRM1552C1H5R6BA01#
				±0.25pF	GRM1552C1H5R6CA01#
				±0.5pF	GRM1552C1H5R6DA01#
5.7pF	±0.05pF	GRM1552C1H5R7WA01#			
	±0.25pF	GRM1552C1H5R7CA01#			

T 最大值	额定 电压	温度特 性代号	静电容量	公差	品名
0.55mm	50Vdc	CH	5.7pF	±0.1pF	GRM1552C1H5R7BA01#
				±0.25pF	GRM1552C1H5R7CA01#
				±0.5pF	GRM1552C1H5R7DA01#
			5.8pF	±0.05pF	GRM1552C1H5R8WA01#
				±0.1pF	GRM1552C1H5R8BA01#
				±0.25pF	GRM1552C1H5R8CA01#
			5.9pF	±0.05pF	GRM1552C1H5R9WA01#
				±0.1pF	GRM1552C1H5R9BA01#
				±0.25pF	GRM1552C1H5R9CA01#
			6.0pF	±0.05pF	GRM1552C1H6R0WA01#
				±0.1pF	GRM1552C1H6R0BA01#
				±0.25pF	GRM1552C1H6R0CA01#
			6.1pF	±0.05pF	GRM1552C1H6R1WA01#
				±0.1pF	GRM1552C1H6R1BA01#
				±0.25pF	GRM1552C1H6R1CA01#
			6.2pF	±0.05pF	GRM1552C1H6R2WA01#
				±0.1pF	GRM1552C1H6R2BA01#
				±0.25pF	GRM1552C1H6R2CA01#
			6.3pF	±0.05pF	GRM1552C1H6R3WA01#
				±0.1pF	GRM1552C1H6R3BA01#
				±0.25pF	GRM1552C1H6R3CA01#
			6.4pF	±0.05pF	GRM1552C1H6R4WA01#
				±0.1pF	GRM1552C1H6R4BA01#
				±0.25pF	GRM1552C1H6R4CA01#
			6.5pF	±0.05pF	GRM1552C1H6R5WA01#
				±0.1pF	GRM1552C1H6R5BA01#
				±0.25pF	GRM1552C1H6R5CA01#
			6.6pF	±0.05pF	GRM1552C1H6R6WA01#
				±0.1pF	GRM1552C1H6R6BA01#
				±0.25pF	GRM1552C1H6R6CA01#
			6.7pF	±0.05pF	GRM1552C1H6R7WA01#
				±0.1pF	GRM1552C1H6R7BA01#
				±0.25pF	GRM1552C1H6R7CA01#
			6.8pF	±0.05pF	GRM1552C1H6R8WA01#
				±0.1pF	GRM1552C1H6R8BA01#
				±0.25pF	GRM1552C1H6R8CA01#
			6.9pF	±0.05pF	GRM1552C1H6R9WA01#
				±0.1pF	GRM1552C1H6R9BA01#
				±0.25pF	GRM1552C1H6R9CA01#
			7.0pF	±0.05pF	GRM1552C1H7R0WA01#
				±0.1pF	GRM1552C1H7R0BA01#
				±0.25pF	GRM1552C1H7R0CA01#

品名 # 表示包装规格代码。

GRM 系列
GJM 系列
GMA 系列
GMD 系列
GQM 系列
GRJ 系列
GR3 系列
KRM 系列
KR3 系列
LLA 系列
LLL 系列
LLM 系列
LLR 系列
警告/注意事项

GRM 系列温度补偿型品名列表

(→ ■ 1.0×0.5mm)

T 最大值	额定 电压	温度特 性代号	静电容量	公差	品名	
0.55mm	50Vdc	CH	7.0pF	±0.5pF	GRM1552C1H7R0DA01#	
				±0.05pF	GRM1552C1H7R1WA01#	
					±0.1pF	GRM1552C1H7R1BA01#
					±0.25pF	GRM1552C1H7R1CA01#
				±0.5pF	GRM1552C1H7R1DA01#	
			7.2pF	±0.05pF	GRM1552C1H7R2WA01#	
				±0.1pF	GRM1552C1H7R2BA01#	
				±0.25pF	GRM1552C1H7R2CA01#	
				±0.5pF	GRM1552C1H7R2DA01#	
				7.3pF	±0.05pF	GRM1552C1H7R3WA01#
			±0.1pF		GRM1552C1H7R3BA01#	
			±0.25pF		GRM1552C1H7R3CA01#	
			±0.5pF		GRM1552C1H7R3DA01#	
			7.4pF		±0.05pF	GRM1552C1H7R4WA01#
				±0.1pF	GRM1552C1H7R4BA01#	
				±0.25pF	GRM1552C1H7R4CA01#	
				±0.5pF	GRM1552C1H7R4DA01#	
				7.5pF	±0.05pF	GRM1552C1H7R5WA01#
			±0.1pF		GRM1552C1H7R5BA01#	
			±0.25pF		GRM1552C1H7R5CA01#	
			±0.5pF		GRM1552C1H7R5DA01#	
			7.6pF		±0.05pF	GRM1552C1H7R6WA01#
				±0.1pF	GRM1552C1H7R6BA01#	
				±0.25pF	GRM1552C1H7R6CA01#	
				±0.5pF	GRM1552C1H7R6DA01#	
				7.7pF	±0.05pF	GRM1552C1H7R7WA01#
			±0.1pF		GRM1552C1H7R7BA01#	
			±0.25pF		GRM1552C1H7R7CA01#	
			±0.5pF		GRM1552C1H7R7DA01#	
			7.8pF		±0.05pF	GRM1552C1H7R8WA01#
				±0.1pF	GRM1552C1H7R8BA01#	
				±0.25pF	GRM1552C1H7R8CA01#	
				±0.5pF	GRM1552C1H7R8DA01#	
				7.9pF	±0.05pF	GRM1552C1H7R9WA01#
			±0.1pF		GRM1552C1H7R9BA01#	
			±0.25pF		GRM1552C1H7R9CA01#	
			±0.5pF		GRM1552C1H7R9DA01#	
			8.0pF		±0.05pF	GRM1552C1H8R0WA01#
				±0.1pF	GRM1552C1H8R0BA01#	
				±0.25pF	GRM1552C1H8R0CA01#	
				±0.5pF	GRM1552C1H8R0DA01#	
				8.1pF	±0.05pF	GRM1552C1H8R1WA01#
			±0.1pF		GRM1552C1H8R1BA01#	
			±0.25pF		GRM1552C1H8R1CA01#	
			±0.5pF		GRM1552C1H8R1DA01#	
			8.2pF		±0.05pF	GRM1552C1H8R2WA01#
				±0.1pF	GRM1552C1H8R2BA01#	
				±0.25pF	GRM1552C1H8R2CA01#	
±0.5pF	GRM1552C1H8R2DA01#					
8.3pF	±0.05pF	GRM1552C1H8R3WA01#				
	±0.1pF	GRM1552C1H8R3BA01#				
	±0.25pF	GRM1552C1H8R3CA01#				
	±0.5pF	GRM1552C1H8R3DA01#				
	8.4pF	±0.05pF	GRM1552C1H8R4WA01#			

T 最大值	额定 电压	温度特 性代号	静电容量	公差	品名
0.55mm	50Vdc	CH	8.4pF	±0.1pF	GRM1552C1H8R4BA01#
				±0.25pF	GRM1552C1H8R4CA01#
				±0.5pF	GRM1552C1H8R4DA01#
			8.5pF	±0.05pF	GRM1552C1H8R5WA01#
				±0.1pF	GRM1552C1H8R5BA01#
				±0.25pF	GRM1552C1H8R5CA01#
			±0.5pF	GRM1552C1H8R5DA01#	
			8.6pF	±0.05pF	GRM1552C1H8R6WA01#
				±0.1pF	GRM1552C1H8R6BA01#
				±0.25pF	GRM1552C1H8R6CA01#
			±0.5pF	GRM1552C1H8R6DA01#	
			8.7pF	±0.05pF	GRM1552C1H8R7WA01#
				±0.1pF	GRM1552C1H8R7BA01#
				±0.25pF	GRM1552C1H8R7CA01#
			±0.5pF	GRM1552C1H8R7DA01#	
			8.8pF	±0.05pF	GRM1552C1H8R8WA01#
				±0.1pF	GRM1552C1H8R8BA01#
				±0.25pF	GRM1552C1H8R8CA01#
			±0.5pF	GRM1552C1H8R8DA01#	
			8.9pF	±0.05pF	GRM1552C1H8R9WA01#
				±0.1pF	GRM1552C1H8R9BA01#
				±0.25pF	GRM1552C1H8R9CA01#
			±0.5pF	GRM1552C1H8R9DA01#	
			9.0pF	±0.05pF	GRM1552C1H9R0WA01#
				±0.1pF	GRM1552C1H9R0BA01#
				±0.25pF	GRM1552C1H9R0CA01#
			±0.5pF	GRM1552C1H9R0DA01#	
			9.1pF	±0.05pF	GRM1552C1H9R1WA01#
				±0.1pF	GRM1552C1H9R1BA01#
				±0.25pF	GRM1552C1H9R1CA01#
			±0.5pF	GRM1552C1H9R1DA01#	
			9.2pF	±0.05pF	GRM1552C1H9R2WA01#
				±0.1pF	GRM1552C1H9R2BA01#
				±0.25pF	GRM1552C1H9R2CA01#
			±0.5pF	GRM1552C1H9R2DA01#	
			9.3pF	±0.05pF	GRM1552C1H9R3WA01#
				±0.1pF	GRM1552C1H9R3BA01#
				±0.25pF	GRM1552C1H9R3CA01#
			±0.5pF	GRM1552C1H9R3DA01#	
			9.4pF	±0.05pF	GRM1552C1H9R4WA01#
				±0.1pF	GRM1552C1H9R4BA01#
				±0.25pF	GRM1552C1H9R4CA01#
			±0.5pF	GRM1552C1H9R4DA01#	
			9.5pF	±0.05pF	GRM1552C1H9R5WA01#
				±0.1pF	GRM1552C1H9R5BA01#
				±0.25pF	GRM1552C1H9R5CA01#
			±0.5pF	GRM1552C1H9R5DA01#	
			9.6pF	±0.05pF	GRM1552C1H9R6WA01#
±0.1pF	GRM1552C1H9R6BA01#				
±0.25pF	GRM1552C1H9R6CA01#				
±0.5pF	GRM1552C1H9R6DA01#				
9.7pF	±0.05pF	GRM1552C1H9R7WA01#			
	±0.1pF	GRM1552C1H9R7BA01#			
	±0.25pF	GRM1552C1H9R7CA01#			

品名 # 表示包装规格代码。

GRM 系列
GJM 系列
GMA 系列
GMD 系列
GQM 系列
GRJ 系列
GR3 系列
KRM 系列
KR3 系列
LLA 系列
LLL 系列
LLM 系列
LLR 系列
警告 / 注意事項

GRM 系列温度补偿型品名列表

(→ ■ 1.0×0.5mm)

T 最大值	额定 电压	温度特 性代号	静电容量	公差	品名
0.55mm	50Vdc	CH	9.7pF	±0.5pF	GRM1552C1H9R7DA01#
				±0.05pF	GRM1552C1H9R8WA01#
			9.8pF	±0.1pF	GRM1552C1H9R8BA01#
				±0.25pF	GRM1552C1H9R8CA01#
				±0.5pF	GRM1552C1H9R8DA01#
				9.9pF	±0.05pF
			±0.1pF		GRM1552C1H9R9BA01#
			±0.25pF		GRM1552C1H9R9CA01#
			±0.5pF		GRM1552C1H9R9DA01#
			10pF	±2%	GRM1552C1H100GA01#
				±5%	GRM1552C1H100JA01#
			12pF	±2%	GRM1552C1H120GA01#
				±5%	GRM1552C1H120JA01#
			15pF	±2%	GRM1552C1H150GA01#
				±5%	GRM1552C1H150JA01#
			18pF	±2%	GRM1552C1H180GA01#
				±5%	GRM1552C1H180JA01#
			22pF	±2%	GRM1552C1H220GA01#
				±5%	GRM1552C1H220JA01#
			27pF	±2%	GRM1552C1H270GA01#
				±5%	GRM1552C1H270JA01#
			33pF	±2%	GRM1552C1H330GA01#
				±5%	GRM1552C1H330JA01#
			39pF	±2%	GRM1552C1H390GA01#
				±5%	GRM1552C1H390JA01#
			47pF	±2%	GRM1552C1H470GA01#
				±5%	GRM1552C1H470JA01#
			56pF	±2%	GRM1552C1H560GA01#
				±5%	GRM1552C1H560JA01#
			68pF	±2%	GRM1552C1H680GA01#
				±5%	GRM1552C1H680JA01#
			82pF	±2%	GRM1552C1H820GA01#
				±5%	GRM1552C1H820JA01#
			100pF	±2%	GRM1552C1H101GA01#
				±5%	GRM1552C1H101JA01#
			120pF	±2%	GRM1552C1H121GA01#
				±5%	GRM1552C1H121JA01#
			150pF	±2%	GRM1552C1H151GA01#
				±5%	GRM1552C1H151JA01#
			180pF	±2%	GRM1552C1H181GA01#
				±5%	GRM1552C1H181JA01#
			220pF	±2%	GRM1552C1H221GA01#
±5%	GRM1552C1H221JA01#				
270pF	±2%	GRM1552C1H271GA01#			
	±5%	GRM1552C1H271JA01#			
330pF	±2%	GRM1552C1H331GA01#			
	±5%	GRM1552C1H331JA01#			
390pF	±2%	GRM1552C1H391GA01#			
	±5%	GRM1552C1H391JA01#			
470pF	±2%	GRM1552C1H471GA01#			
	±5%	GRM1552C1H471JA01#			
560pF	±2%	GRM1552C1H561GA01#			
	±5%	GRM1552C1H561JA01#			
680pF	±2%	GRM1552C1H681GA01#			

T 最大值	额定 电压	温度特 性代号	静电容量	公差	品名		
0.55mm	50Vdc	CH	680pF	±5%	GRM1552C1H681JA01#		
				±2%	GRM1552C1H821GA01#		
			820pF	±5%	GRM1552C1H821JA01#		
				±2%	GRM1552C1H102GA01#		
				±5%	GRM1552C1H102JA01#		
			10Vdc	SL	1200pF	±5%	GRM1551X1A122JA01#
						±5%	GRM1551X1A152JA01#
					1500pF	±5%	GRM1551X1A182JA01#
						±5%	GRM1551X1A222JA01#
					2200pF	±5%	GRM1551X1A272JA01#
						±5%	GRM1551X1A332JA01#
				U2J	1200pF	±5%	GRM1557U1A122JA01#
	±5%	GRM1557U1A152JA01#					
	1500pF	±5%			GRM1557U1A182JA01#		
		±5%			GRM1557U1A222JA01#		
	2200pF	±5%			GRM1557U1A272JA01#		
		±5%			GRM1557U1A332JA01#		
	UJ	1200pF	±5%	GRM1553U1A122JA01#			
			±5%	GRM1553U1A152JA01#			
		1500pF	±5%	GRM1553U1A182JA01#			
			±5%	GRM1553U1A222JA01#			
		2200pF	±5%	GRM1553U1A272JA01#			
			±5%	GRM1553U1A332JA01#			

■ 1.6×0.8mm

T 最大值	额定 电压	温度特 性代号	静电容量	公差	品名	
0.5mm	50Vdc	SL	2200pF	±5%	GRM1851X1H222JA44#	
				±5%	GRM1851X1H272JA44#	
			3300pF	±5%	GRM1851X1H332JA44#	
				±5%	GRM1851X1H392JA44#	
				±5%	GRM1851X1H472JA44#	
			U2J	2200pF	±5%	GRM1857U1H222JA44#
					±5%	GRM1857U1H272JA44#
				3300pF	±5%	GRM1857U1H332JA44#
					±5%	GRM1857U1H392JA44#
				4700pF	±5%	GRM1857U1H472JA44#
					UJ	2200pF
			±5%	GRM1853U1H272JA44#		
	3300pF	±5%	GRM1853U1H332JA44#			
		±5%	GRM1853U1H392JA44#			
	4700pF	±5%	GRM1853U1H472JA44#			
		10Vdc	SL	5600pF		±5%
	±5%				GRM1851X1A682JA44#	
	8200pF		±5%	GRM1851X1A822JA44#		
			±5%	GRM1851X1A103JA44#		
	10000pF		±5%	GRM1851X1A103JA44#		
			U2J	5600pF	±5%	GRM1857U1A562JA44#

品名 # 表示包装规格代码。

GRM 系列
GJM 系列
GMA 系列
GMD 系列
GQM 系列
GRJ 系列
GR3 系列
KRM 系列
KR3 系列
LLA 系列
LLL 系列
LLM 系列
LLR 系列
警告/注意事项

GRM 系列温度补偿型品名列表

(→ ■ 1.6×0.8mm)

T 最大值	额定 电压	温度特 性代号	静电容量	公差	品名				
0.5mm	10Vdc	U2J	6800pF	±5%	GRM1857U1A682JA44#				
			8200pF	±5%	GRM1857U1A822JA44#				
			10000pF	±5%	GRM1857U1A103JA44#				
		UJ	5600pF	±5%	GRM1853U1A562JA44#				
			6800pF	±5%	GRM1853U1A682JA44#				
			8200pF	±5%	GRM1853U1A822JA44#				
			10000pF	±5%	GRM1853U1A103JA44#				
			0.9mm 100Vdc C0G						
								0.50pF	±0.05pF
		±0.1pF							GRM1885C2AR50BA01#
		0.60pF						±0.05pF	GRM1885C2AR60WA01#
								±0.1pF	GRM1885C2AR60BA01#
0.70pF	±0.05pF	GRM1885C2AR70WA01#							
	±0.1pF	GRM1885C2AR70BA01#							
0.80pF	±0.05pF	GRM1885C2AR80WA01#							
	±0.1pF	GRM1885C2AR80BA01#							
0.90pF	±0.05pF	GRM1885C2AR90WA01#							
	±0.1pF	GRM1885C2AR90BA01#							
1.0pF	±0.05pF	GRM1885C2A1R0WA01#							
	±0.1pF	GRM1885C2A1R0BA01#							
	±0.25pF	GRM1885C2A1R0CA01#							
1.1pF	±0.05pF	GRM1885C2A1R1WA01#							
	±0.1pF	GRM1885C2A1R1BA01#							
	±0.25pF	GRM1885C2A1R1CA01#							
1.2pF	±0.05pF	GRM1885C2A1R2WA01#							
	±0.1pF	GRM1885C2A1R2BA01#							
	±0.25pF	GRM1885C2A1R2CA01#							
1.3pF	±0.05pF	GRM1885C2A1R3WA01#							
	±0.1pF	GRM1885C2A1R3BA01#							
	±0.25pF	GRM1885C2A1R3CA01#							
1.4pF	±0.05pF	GRM1885C2A1R4WA01#							
	±0.1pF	GRM1885C2A1R4BA01#							
	±0.25pF	GRM1885C2A1R4CA01#							
1.5pF	±0.05pF	GRM1885C2A1R5WA01#							
	±0.1pF	GRM1885C2A1R5BA01#							
	±0.25pF	GRM1885C2A1R5CA01#							
1.6pF	±0.05pF	GRM1885C2A1R6WA01#							
	±0.1pF	GRM1885C2A1R6BA01#							
	±0.25pF	GRM1885C2A1R6CA01#							
1.7pF	±0.05pF	GRM1885C2A1R7WA01#							
	±0.1pF	GRM1885C2A1R7BA01#							
	±0.25pF	GRM1885C2A1R7CA01#							
1.8pF	±0.05pF	GRM1885C2A1R8WA01#							
	±0.1pF	GRM1885C2A1R8BA01#							
	±0.25pF	GRM1885C2A1R8CA01#							
1.9pF	±0.05pF	GRM1885C2A1R9WA01#							
	±0.1pF	GRM1885C2A1R9BA01#							
	±0.25pF	GRM1885C2A1R9CA01#							
2.0pF	±0.05pF	GRM1885C2A2R0WA01#							
	±0.1pF	GRM1885C2A2R0BA01#							
	±0.25pF	GRM1885C2A2R0CA01#							
2.1pF	±0.05pF	GRM1885C2A2R1WA01#							
	±0.1pF	GRM1885C2A2R1BA01#							
	±0.25pF	GRM1885C2A2R1CA01#							
2.2pF	±0.05pF	GRM1885C2A2R2WA01#							

T 最大值	额定 电压	温度特 性代号	静电容量	公差	品名
0.9mm	100Vdc	C0G	2.2pF	±0.1pF	GRM1885C2A2R2BA01#
				±0.25pF	GRM1885C2A2R2CA01#
			2.3pF	±0.05pF	GRM1885C2A2R3WA01#
				±0.1pF	GRM1885C2A2R3BA01#
			2.4pF	±0.05pF	GRM1885C2A2R4WA01#
				±0.1pF	GRM1885C2A2R4BA01#
			2.5pF	±0.05pF	GRM1885C2A2R5WA01#
				±0.1pF	GRM1885C2A2R5BA01#
			2.6pF	±0.05pF	GRM1885C2A2R6WA01#
				±0.1pF	GRM1885C2A2R6BA01#
			2.7pF	±0.05pF	GRM1885C2A2R7WA01#
				±0.1pF	GRM1885C2A2R7BA01#
			2.8pF	±0.05pF	GRM1885C2A2R8WA01#
				±0.1pF	GRM1885C2A2R8BA01#
			2.9pF	±0.05pF	GRM1885C2A2R9WA01#
				±0.1pF	GRM1885C2A2R9BA01#
			3.0pF	±0.05pF	GRM1885C2A3R0WA01#
				±0.1pF	GRM1885C2A3R0BA01#
			3.1pF	±0.05pF	GRM1885C2A3R1WA01#
				±0.1pF	GRM1885C2A3R1BA01#
			3.2pF	±0.05pF	GRM1885C2A3R2WA01#
				±0.1pF	GRM1885C2A3R2BA01#
			3.3pF	±0.05pF	GRM1885C2A3R3WA01#
				±0.1pF	GRM1885C2A3R3BA01#
			3.4pF	±0.05pF	GRM1885C2A3R4WA01#
				±0.1pF	GRM1885C2A3R4BA01#
			3.5pF	±0.05pF	GRM1885C2A3R5WA01#
				±0.1pF	GRM1885C2A3R5BA01#
			3.6pF	±0.05pF	GRM1885C2A3R6WA01#
				±0.1pF	GRM1885C2A3R6BA01#
			3.7pF	±0.05pF	GRM1885C2A3R7WA01#
				±0.1pF	GRM1885C2A3R7BA01#
			3.8pF	±0.05pF	GRM1885C2A3R8WA01#
				±0.1pF	GRM1885C2A3R8BA01#
			3.9pF	±0.05pF	GRM1885C2A3R9WA01#
				±0.1pF	GRM1885C2A3R9BA01#
			4.0pF	±0.05pF	GRM1885C2A4R0WA01#

品名 # 表示包装规格代码。

- GRM 系列
- GJM 系列
- GMA 系列
- GMD 系列
- GQM 系列
- GRJ 系列
- GR3 系列
- KRM 系列
- KR3 系列
- LJA 系列
- LLL 系列
- LJM 系列
- LLR 系列
- 警告 / 注意事项

GRM 系列温度补偿型品名列表

(→ ■ 1.6×0.8mm)

T 最大值	额定 电压	温度特 性代号	静电容量	公差	品名	
0.9mm	100Vdc	C0G	4.0pF	±0.1pF	GRM1885C2A4R0BA01#	
				±0.25pF	GRM1885C2A4R0CA01#	
			4.1pF	±0.05pF	GRM1885C2A4R1WA01#	
				±0.1pF	GRM1885C2A4R1BA01#	
				±0.25pF	GRM1885C2A4R1CA01#	
			4.2pF	±0.05pF	GRM1885C2A4R2WA01#	
				±0.1pF	GRM1885C2A4R2BA01#	
				±0.25pF	GRM1885C2A4R2CA01#	
			4.3pF	±0.05pF	GRM1885C2A4R3WA01#	
				±0.1pF	GRM1885C2A4R3BA01#	
				±0.25pF	GRM1885C2A4R3CA01#	
			4.4pF	±0.05pF	GRM1885C2A4R4WA01#	
				±0.1pF	GRM1885C2A4R4BA01#	
				±0.25pF	GRM1885C2A4R4CA01#	
			4.5pF	±0.05pF	GRM1885C2A4R5WA01#	
				±0.1pF	GRM1885C2A4R5BA01#	
				±0.25pF	GRM1885C2A4R5CA01#	
			4.6pF	±0.05pF	GRM1885C2A4R6WA01#	
				±0.1pF	GRM1885C2A4R6BA01#	
				±0.25pF	GRM1885C2A4R6CA01#	
			4.7pF	±0.05pF	GRM1885C2A4R7WA01#	
				±0.1pF	GRM1885C2A4R7BA01#	
				±0.25pF	GRM1885C2A4R7CA01#	
			4.8pF	±0.05pF	GRM1885C2A4R8WA01#	
				±0.1pF	GRM1885C2A4R8BA01#	
				±0.25pF	GRM1885C2A4R8CA01#	
			4.9pF	±0.05pF	GRM1885C2A4R9WA01#	
				±0.1pF	GRM1885C2A4R9BA01#	
				±0.25pF	GRM1885C2A4R9CA01#	
			5.0pF	±0.05pF	GRM1885C2A5R0WA01#	
				±0.1pF	GRM1885C2A5R0BA01#	
				±0.25pF	GRM1885C2A5R0CA01#	
				5.1pF	±0.05pF	GRM1885C2A5R1WA01#
					±0.1pF	GRM1885C2A5R1BA01#
					±0.25pF	GRM1885C2A5R1CA01#
			5.2pF	±0.05pF	GRM1885C2A5R2WA01#	
				±0.1pF	GRM1885C2A5R2BA01#	
				±0.25pF	GRM1885C2A5R2CA01#	
				±0.5pF	GRM1885C2A5R2DA01#	
			5.3pF	±0.05pF	GRM1885C2A5R3WA01#	
				±0.1pF	GRM1885C2A5R3BA01#	
				±0.25pF	GRM1885C2A5R3CA01#	
				±0.5pF	GRM1885C2A5R3DA01#	
			5.4pF	±0.05pF	GRM1885C2A5R4WA01#	
				±0.1pF	GRM1885C2A5R4BA01#	
				±0.25pF	GRM1885C2A5R4CA01#	
				±0.5pF	GRM1885C2A5R4DA01#	
			5.5pF	±0.05pF	GRM1885C2A5R5WA01#	
				±0.1pF	GRM1885C2A5R5BA01#	
				±0.25pF	GRM1885C2A5R5CA01#	
				±0.5pF	GRM1885C2A5R5DA01#	
			5.6pF	±0.05pF	GRM1885C2A5R6WA01#	
				±0.1pF	GRM1885C2A5R6BA01#	

T 最大值	额定 电压	温度特 性代号	静电容量	公差	品名
0.9mm	100Vdc	C0G	5.6pF	±0.25pF	GRM1885C2A5R6CA01#
				±0.5pF	GRM1885C2A5R6DA01#
			5.7pF	±0.05pF	GRM1885C2A5R7WA01#
				±0.1pF	GRM1885C2A5R7BA01#
				±0.25pF	GRM1885C2A5R7CA01#
			5.8pF	±0.05pF	GRM1885C2A5R8WA01#
				±0.1pF	GRM1885C2A5R8BA01#
				±0.25pF	GRM1885C2A5R8CA01#
			5.9pF	±0.05pF	GRM1885C2A5R9WA01#
				±0.1pF	GRM1885C2A5R9BA01#
				±0.25pF	GRM1885C2A5R9CA01#
			6.0pF	±0.05pF	GRM1885C2A6R0WA01#
				±0.1pF	GRM1885C2A6R0BA01#
				±0.25pF	GRM1885C2A6R0CA01#
			6.1pF	±0.05pF	GRM1885C2A6R1WA01#
				±0.1pF	GRM1885C2A6R1BA01#
				±0.25pF	GRM1885C2A6R1CA01#
			6.2pF	±0.05pF	GRM1885C2A6R2WA01#
				±0.1pF	GRM1885C2A6R2BA01#
				±0.25pF	GRM1885C2A6R2CA01#
			6.3pF	±0.05pF	GRM1885C2A6R3WA01#
				±0.1pF	GRM1885C2A6R3BA01#
				±0.25pF	GRM1885C2A6R3CA01#
			6.4pF	±0.05pF	GRM1885C2A6R4WA01#
				±0.1pF	GRM1885C2A6R4BA01#
				±0.25pF	GRM1885C2A6R4CA01#
			6.5pF	±0.05pF	GRM1885C2A6R5WA01#
				±0.1pF	GRM1885C2A6R5BA01#
				±0.25pF	GRM1885C2A6R5CA01#
			6.6pF	±0.05pF	GRM1885C2A6R6WA01#
				±0.1pF	GRM1885C2A6R6BA01#
				±0.25pF	GRM1885C2A6R6CA01#
			6.7pF	±0.05pF	GRM1885C2A6R7WA01#
				±0.1pF	GRM1885C2A6R7BA01#
				±0.25pF	GRM1885C2A6R7CA01#
			6.8pF	±0.05pF	GRM1885C2A6R8WA01#
				±0.1pF	GRM1885C2A6R8BA01#
				±0.25pF	GRM1885C2A6R8CA01#
			6.9pF	±0.05pF	GRM1885C2A6R9WA01#
				±0.1pF	GRM1885C2A6R9BA01#
				±0.25pF	GRM1885C2A6R9CA01#

品名 # 表示包装规格代码。

GRM 系列
GJM 系列
GMA 系列
GMD 系列
GQM 系列
GRJ 系列
GR3 系列
KRM 系列
KR3 系列
LLA 系列
LLL 系列
LLM 系列
LLR 系列
警告/注意事项

GRM 系列温度补偿型品名列表

(→ ■ 1.6×0.8mm)

T 最大值	额定 电压	温度特 性代号	静电容量	公差	品名
0.9mm	100Vdc	C0G	7.0pF	±0.05pF	GRM1885C2A7R0WA01#
				±0.1pF	GRM1885C2A7R0BA01#
				±0.25pF	GRM1885C2A7R0CA01#
				±0.5pF	GRM1885C2A7R0DA01#
			7.1pF	±0.05pF	GRM1885C2A7R1WA01#
				±0.1pF	GRM1885C2A7R1BA01#
				±0.25pF	GRM1885C2A7R1CA01#
				±0.5pF	GRM1885C2A7R1DA01#
			7.2pF	±0.05pF	GRM1885C2A7R2WA01#
				±0.1pF	GRM1885C2A7R2BA01#
				±0.25pF	GRM1885C2A7R2CA01#
				±0.5pF	GRM1885C2A7R2DA01#
			7.3pF	±0.05pF	GRM1885C2A7R3WA01#
				±0.1pF	GRM1885C2A7R3BA01#
				±0.25pF	GRM1885C2A7R3CA01#
				±0.5pF	GRM1885C2A7R3DA01#
			7.4pF	±0.05pF	GRM1885C2A7R4WA01#
				±0.1pF	GRM1885C2A7R4BA01#
				±0.25pF	GRM1885C2A7R4CA01#
				±0.5pF	GRM1885C2A7R4DA01#
			7.5pF	±0.05pF	GRM1885C2A7R5WA01#
				±0.1pF	GRM1885C2A7R5BA01#
				±0.25pF	GRM1885C2A7R5CA01#
				±0.5pF	GRM1885C2A7R5DA01#
			7.6pF	±0.05pF	GRM1885C2A7R6WA01#
				±0.1pF	GRM1885C2A7R6BA01#
				±0.25pF	GRM1885C2A7R6CA01#
				±0.5pF	GRM1885C2A7R6DA01#
			7.7pF	±0.05pF	GRM1885C2A7R7WA01#
				±0.1pF	GRM1885C2A7R7BA01#
				±0.25pF	GRM1885C2A7R7CA01#
				±0.5pF	GRM1885C2A7R7DA01#
			7.8pF	±0.05pF	GRM1885C2A7R8WA01#
				±0.1pF	GRM1885C2A7R8BA01#
				±0.25pF	GRM1885C2A7R8CA01#
				±0.5pF	GRM1885C2A7R8DA01#
			7.9pF	±0.05pF	GRM1885C2A7R9WA01#
				±0.1pF	GRM1885C2A7R9BA01#
				±0.25pF	GRM1885C2A7R9CA01#
				±0.5pF	GRM1885C2A7R9DA01#
			8.0pF	±0.05pF	GRM1885C2A8R0WA01#
				±0.1pF	GRM1885C2A8R0BA01#
				±0.25pF	GRM1885C2A8R0CA01#
				±0.5pF	GRM1885C2A8R0DA01#
			8.1pF	±0.05pF	GRM1885C2A8R1WA01#
				±0.1pF	GRM1885C2A8R1BA01#
				±0.25pF	GRM1885C2A8R1CA01#
				±0.5pF	GRM1885C2A8R1DA01#
			8.2pF	±0.05pF	GRM1885C2A8R2WA01#
				±0.1pF	GRM1885C2A8R2BA01#
				±0.25pF	GRM1885C2A8R2CA01#
				±0.5pF	GRM1885C2A8R2DA01#
			8.3pF	±0.05pF	GRM1885C2A8R3WA01#
				±0.1pF	GRM1885C2A8R3BA01#

T 最大值	额定 电压	温度特 性代号	静电容量	公差	品名
0.9mm	100Vdc	C0G	8.3pF	±0.25pF	GRM1885C2A8R3CA01#
				±0.5pF	GRM1885C2A8R3DA01#
			8.4pF	±0.05pF	GRM1885C2A8R4WA01#
				±0.1pF	GRM1885C2A8R4BA01#
				±0.25pF	GRM1885C2A8R4CA01#
			8.5pF	±0.05pF	GRM1885C2A8R5WA01#
				±0.1pF	GRM1885C2A8R5BA01#
				±0.25pF	GRM1885C2A8R5CA01#
			8.6pF	±0.05pF	GRM1885C2A8R6WA01#
				±0.1pF	GRM1885C2A8R6BA01#
				±0.25pF	GRM1885C2A8R6CA01#
			8.7pF	±0.05pF	GRM1885C2A8R7WA01#
				±0.1pF	GRM1885C2A8R7BA01#
				±0.25pF	GRM1885C2A8R7CA01#
			8.8pF	±0.05pF	GRM1885C2A8R8WA01#
				±0.1pF	GRM1885C2A8R8BA01#
				±0.25pF	GRM1885C2A8R8CA01#
			8.9pF	±0.05pF	GRM1885C2A8R9WA01#
				±0.1pF	GRM1885C2A8R9BA01#
				±0.25pF	GRM1885C2A8R9CA01#
			9.0pF	±0.05pF	GRM1885C2A9R0WA01#
				±0.1pF	GRM1885C2A9R0BA01#
				±0.25pF	GRM1885C2A9R0CA01#
			9.1pF	±0.05pF	GRM1885C2A9R1WA01#
				±0.1pF	GRM1885C2A9R1BA01#
				±0.25pF	GRM1885C2A9R1CA01#
			9.2pF	±0.05pF	GRM1885C2A9R2WA01#
				±0.1pF	GRM1885C2A9R2BA01#
				±0.25pF	GRM1885C2A9R2CA01#
			9.3pF	±0.05pF	GRM1885C2A9R3WA01#
				±0.1pF	GRM1885C2A9R3BA01#
				±0.25pF	GRM1885C2A9R3CA01#
			9.4pF	±0.05pF	GRM1885C2A9R4WA01#
				±0.1pF	GRM1885C2A9R4BA01#
				±0.25pF	GRM1885C2A9R4CA01#
			9.5pF	±0.05pF	GRM1885C2A9R5WA01#
				±0.1pF	GRM1885C2A9R5BA01#
				±0.25pF	GRM1885C2A9R5CA01#
			9.6pF	±0.05pF	GRM1885C2A9R6WA01#
				±0.1pF	GRM1885C2A9R6BA01#
				±0.25pF	GRM1885C2A9R6CA01#

品名 # 表示包装规格代码。

- GRM 系列
- GJM 系列
- GMA 系列
- GMD 系列
- GQM 系列
- GRJ 系列
- GR3 系列
- KRM 系列
- KR3 系列
- LJA 系列
- LLL 系列
- LJM 系列
- LLR 系列
- 警告 / 注意事项

GRM 系列温度补偿型品名列表

(→ ■ 1.6×0.8mm)

T 最大值	额定 电压	温度特 性代号	静电容量	公差	品名			
0.9mm	100Vdc	C0G	9.7pF	±0.05pF	GRM1885C2A9R7WA01#			
				±0.1pF	GRM1885C2A9R7BA01#			
				±0.25pF	GRM1885C2A9R7CA01#			
				±0.5pF	GRM1885C2A9R7DA01#			
			9.8pF	±0.05pF	GRM1885C2A9R8WA01#			
				±0.1pF	GRM1885C2A9R8BA01#			
				±0.25pF	GRM1885C2A9R8CA01#			
				±0.5pF	GRM1885C2A9R8DA01#			
			9.9pF	±0.05pF	GRM1885C2A9R9WA01#			
				±0.1pF	GRM1885C2A9R9BA01#			
				±0.25pF	GRM1885C2A9R9CA01#			
				±0.5pF	GRM1885C2A9R9DA01#			
			10pF	±5%	GRM1885C2A100JA01#			
			12pF	±5%	GRM1885C2A120JA01#			
			15pF	±5%	GRM1885C2A150JA01#			
			18pF	±5%	GRM1885C2A180JA01#			
			22pF	±5%	GRM1885C2A220JA01#			
			27pF	±5%	GRM1885C2A270JA01#			
			33pF	±5%	GRM1885C2A330JA01#			
			39pF	±5%	GRM1885C2A390JA01#			
			47pF	±5%	GRM1885C2A470JA01#			
			56pF	±5%	GRM1885C2A560JA01#			
			68pF	±5%	GRM1885C2A680JA01#			
			82pF	±5%	GRM1885C2A820JA01#			
			100pF	±5%	GRM1885C2A101JA01#			
			120pF	±5%	GRM1885C2A121JA01#			
			150pF	±5%	GRM1885C2A151JA01#			
			180pF	±5%	GRM1885C2A181JA01#			
			220pF	±5%	GRM1885C2A221JA01#			
			270pF	±5%	GRM1885C2A271JA01#			
			330pF	±5%	GRM1885C2A331JA01#			
			390pF	±5%	GRM1885C2A391JA01#			
			470pF	±5%	GRM1885C2A471JA01#			
			560pF	±5%	GRM1885C2A561JA01#			
			680pF	±5%	GRM1885C2A681JA01#			
			820pF	±5%	GRM1885C2A821JA01#			
			1000pF	±5%	GRM1885C2A102JA01#			
			1200pF	±5%	GRM1885C2A122JA01#			
			1500pF	±5%	GRM1885C2A152JA01#			
			0.9mm	100Vdc	CK	0.50pF	±0.05pF	GRM1884C2AR50WA01#
							±0.1pF	GRM1884C2AR50BA01#
						0.60pF	±0.05pF	GRM1884C2AR60WA01#
							±0.1pF	GRM1884C2AR60BA01#
						0.70pF	±0.05pF	GRM1884C2AR70WA01#
							±0.1pF	GRM1884C2AR70BA01#
						0.80pF	±0.05pF	GRM1884C2AR80WA01#
							±0.1pF	GRM1884C2AR80BA01#
0.90pF	±0.05pF	GRM1884C2AR90WA01#						
	±0.1pF	GRM1884C2AR90BA01#						
1.0pF	±0.05pF	GRM1884C2A1R0WA01#						
	±0.1pF	GRM1884C2A1R0BA01#						
	±0.25pF	GRM1884C2A1R0CA01#						
1.1pF	±0.05pF	GRM1884C2A1R1WA01#						
	±0.1pF	GRM1884C2A1R1BA01#						

T 最大值	额定 电压	温度特 性代号	静电容量	公差	品名			
0.9mm	100Vdc	CK	1.1pF	±0.25pF	GRM1884C2A1R1CA01#			
				±0.05pF	GRM1884C2A1R2WA01#			
				±0.1pF	GRM1884C2A1R2BA01#			
				±0.25pF	GRM1884C2A1R2CA01#			
			1.3pF	±0.05pF	GRM1884C2A1R3WA01#			
				±0.1pF	GRM1884C2A1R3BA01#			
				±0.25pF	GRM1884C2A1R3CA01#			
				±0.5pF	GRM1884C2A1R3DA01#			
			1.4pF	±0.05pF	GRM1884C2A1R4WA01#			
				±0.1pF	GRM1884C2A1R4BA01#			
				±0.25pF	GRM1884C2A1R4CA01#			
			1.5pF	±0.05pF	GRM1884C2A1R5WA01#			
				±0.1pF	GRM1884C2A1R5BA01#			
				±0.25pF	GRM1884C2A1R5CA01#			
				±0.5pF	GRM1884C2A1R5DA01#			
			1.6pF	±0.05pF	GRM1884C2A1R6WA01#			
				±0.1pF	GRM1884C2A1R6BA01#			
				±0.25pF	GRM1884C2A1R6CA01#			
				±0.5pF	GRM1884C2A1R6DA01#			
			1.7pF	±0.05pF	GRM1884C2A1R7WA01#			
				±0.1pF	GRM1884C2A1R7BA01#			
				±0.25pF	GRM1884C2A1R7CA01#			
				±0.5pF	GRM1884C2A1R7DA01#			
			1.8pF	±0.05pF	GRM1884C2A1R8WA01#			
				±0.1pF	GRM1884C2A1R8BA01#			
				±0.25pF	GRM1884C2A1R8CA01#			
				±0.5pF	GRM1884C2A1R8DA01#			
			1.9pF	±0.05pF	GRM1884C2A1R9WA01#			
				±0.1pF	GRM1884C2A1R9BA01#			
				±0.25pF	GRM1884C2A1R9CA01#			
				±0.5pF	GRM1884C2A1R9DA01#			
			2.0pF	±0.05pF	GRM1884C2A2R0WA01#			
				±0.1pF	GRM1884C2A2R0BA01#			
				±0.25pF	GRM1884C2A2R0CA01#			
				±0.5pF	GRM1884C2A2R0DA01#			
			0.9mm	100Vdc	CJ	2.1pF	±0.05pF	GRM1883C2A2R1WA01#
							±0.1pF	GRM1883C2A2R1BA01#
							±0.25pF	GRM1883C2A2R1CA01#
						2.2pF	±0.05pF	GRM1883C2A2R2WA01#
							±0.1pF	GRM1883C2A2R2BA01#
							±0.25pF	GRM1883C2A2R2CA01#
						2.3pF	±0.05pF	GRM1883C2A2R3WA01#
							±0.1pF	GRM1883C2A2R3BA01#
							±0.25pF	GRM1883C2A2R3CA01#
						2.4pF	±0.05pF	GRM1883C2A2R4WA01#
							±0.1pF	GRM1883C2A2R4BA01#
							±0.25pF	GRM1883C2A2R4CA01#
2.5pF	±0.05pF	GRM1883C2A2R5WA01#						
	±0.1pF	GRM1883C2A2R5BA01#						
	±0.25pF	GRM1883C2A2R5CA01#						
2.6pF	±0.05pF	GRM1883C2A2R6WA01#						
	±0.1pF	GRM1883C2A2R6BA01#						
	±0.25pF	GRM1883C2A2R6CA01#						
2.7pF	±0.05pF	GRM1883C2A2R7WA01#						
	±0.1pF	GRM1883C2A2R7BA01#						
	±0.25pF	GRM1883C2A2R7CA01#						
2.8pF	±0.05pF	GRM1883C2A2R8WA01#						
	±0.1pF	GRM1883C2A2R8BA01#						
	±0.25pF	GRM1883C2A2R8CA01#						
2.9pF	±0.05pF	GRM1883C2A2R9WA01#						
	±0.1pF	GRM1883C2A2R9BA01#						

品名 # 表示包装规格代码。

GRM 系列
GJM 系列
GMA 系列
GMD 系列
GQM 系列
GRJ 系列
GR3 系列
KRM 系列
KR3 系列
LLA 系列
LLL 系列
LLM 系列
LLR 系列
警告/注意事项

GRM 系列温度补偿型品名列表

(→ ■ 1.6×0.8mm)

T 最大值	额定 电压	温度特 性代号	静电容量	公差	品名	
0.9mm	100Vdc	CJ	2.9pF	±0.25pF	GRM1883C2A2R9CA01#	
				±0.05pF	GRM1883C2A3R0WA01#	
					±0.1pF	GRM1883C2A3R0BA01#
			±0.25pF		GRM1883C2A3R0CA01#	
			3.1pF	±0.05pF	GRM1883C2A3R1WA01#	
				±0.1pF	GRM1883C2A3R1BA01#	
				±0.25pF	GRM1883C2A3R1CA01#	
			3.2pF	±0.05pF	GRM1883C2A3R2WA01#	
				±0.1pF	GRM1883C2A3R2BA01#	
				±0.25pF	GRM1883C2A3R2CA01#	
			3.3pF	±0.05pF	GRM1883C2A3R3WA01#	
				±0.1pF	GRM1883C2A3R3BA01#	
				±0.25pF	GRM1883C2A3R3CA01#	
			3.4pF	±0.05pF	GRM1883C2A3R4WA01#	
				±0.1pF	GRM1883C2A3R4BA01#	
				±0.25pF	GRM1883C2A3R4CA01#	
			3.5pF	±0.05pF	GRM1883C2A3R5WA01#	
				±0.1pF	GRM1883C2A3R5BA01#	
				±0.25pF	GRM1883C2A3R5CA01#	
			3.6pF	±0.05pF	GRM1883C2A3R6WA01#	
				±0.1pF	GRM1883C2A3R6BA01#	
				±0.25pF	GRM1883C2A3R6CA01#	
			3.7pF	±0.05pF	GRM1883C2A3R7WA01#	
				±0.1pF	GRM1883C2A3R7BA01#	
				±0.25pF	GRM1883C2A3R7CA01#	
			3.8pF	±0.05pF	GRM1883C2A3R8WA01#	
				±0.1pF	GRM1883C2A3R8BA01#	
				±0.25pF	GRM1883C2A3R8CA01#	
			3.9pF	±0.05pF	GRM1883C2A3R9WA01#	
				±0.1pF	GRM1883C2A3R9BA01#	
				±0.25pF	GRM1883C2A3R9CA01#	
			CH	4.0pF	±0.05pF	GRM1882C2A4R0WA01#
					±0.1pF	GRM1882C2A4R0BA01#
					±0.25pF	GRM1882C2A4R0CA01#
				4.1pF	±0.05pF	GRM1882C2A4R1WA01#
					±0.1pF	GRM1882C2A4R1BA01#
		±0.25pF			GRM1882C2A4R1CA01#	
		4.2pF		±0.05pF	GRM1882C2A4R2WA01#	
				±0.1pF	GRM1882C2A4R2BA01#	
				±0.25pF	GRM1882C2A4R2CA01#	
		4.3pF		±0.05pF	GRM1882C2A4R3WA01#	
				±0.1pF	GRM1882C2A4R3BA01#	
				±0.25pF	GRM1882C2A4R3CA01#	
		4.4pF		±0.05pF	GRM1882C2A4R4WA01#	
				±0.1pF	GRM1882C2A4R4BA01#	
				±0.25pF	GRM1882C2A4R4CA01#	
		4.5pF		±0.05pF	GRM1882C2A4R5WA01#	
				±0.1pF	GRM1882C2A4R5BA01#	
±0.25pF	GRM1882C2A4R5CA01#					
4.6pF	±0.05pF	GRM1882C2A4R6WA01#				
	±0.1pF	GRM1882C2A4R6BA01#				
	±0.25pF	GRM1882C2A4R6CA01#				
4.7pF	±0.05pF	GRM1882C2A4R7WA01#				
	±0.1pF	GRM1882C2A4R7BA01#				

T 最大值	额定 电压	温度特 性代号	静电容量	公差	品名
0.9mm	100Vdc	CH	4.7pF	±0.25pF	GRM1882C2A4R7CA01#
				±0.05pF	GRM1882C2A4R8WA01#
				±0.1pF	GRM1882C2A4R8BA01#
			±0.25pF	GRM1882C2A4R8CA01#	
			4.9pF	±0.05pF	GRM1882C2A4R9WA01#
				±0.1pF	GRM1882C2A4R9BA01#
				±0.25pF	GRM1882C2A4R9CA01#
			5.0pF	±0.05pF	GRM1882C2A5R0WA01#
				±0.1pF	GRM1882C2A5R0BA01#
				±0.25pF	GRM1882C2A5R0CA01#
			5.1pF	±0.05pF	GRM1882C2A5R1WA01#
				±0.1pF	GRM1882C2A5R1BA01#
				±0.25pF	GRM1882C2A5R1CA01#
			5.2pF	±0.05pF	GRM1882C2A5R2WA01#
				±0.1pF	GRM1882C2A5R2BA01#
				±0.25pF	GRM1882C2A5R2CA01#
			5.3pF	±0.05pF	GRM1882C2A5R3WA01#
				±0.1pF	GRM1882C2A5R3BA01#
				±0.25pF	GRM1882C2A5R3CA01#
			5.4pF	±0.05pF	GRM1882C2A5R4WA01#
				±0.1pF	GRM1882C2A5R4BA01#
				±0.25pF	GRM1882C2A5R4CA01#
			5.5pF	±0.05pF	GRM1882C2A5R5WA01#
				±0.1pF	GRM1882C2A5R5BA01#
				±0.25pF	GRM1882C2A5R5CA01#
			5.6pF	±0.05pF	GRM1882C2A5R6WA01#
				±0.1pF	GRM1882C2A5R6BA01#
				±0.25pF	GRM1882C2A5R6CA01#
			5.7pF	±0.05pF	GRM1882C2A5R7WA01#
				±0.1pF	GRM1882C2A5R7BA01#
				±0.25pF	GRM1882C2A5R7CA01#
			5.8pF	±0.05pF	GRM1882C2A5R8WA01#
				±0.1pF	GRM1882C2A5R8BA01#
				±0.25pF	GRM1882C2A5R8CA01#
			5.9pF	±0.05pF	GRM1882C2A5R9WA01#
				±0.1pF	GRM1882C2A5R9BA01#
				±0.25pF	GRM1882C2A5R9CA01#
			6.0pF	±0.05pF	GRM1882C2A6R0WA01#
				±0.1pF	GRM1882C2A6R0BA01#
				±0.25pF	GRM1882C2A6R0CA01#
			6.1pF	±0.05pF	GRM1882C2A6R1WA01#
				±0.1pF	GRM1882C2A6R1BA01#
				±0.25pF	GRM1882C2A6R1CA01#

品名 # 表示包装规格代码。

- GRM 系列
- GJM 系列
- GMA 系列
- GMD 系列
- GQM 系列
- GRJ 系列
- GR3 系列
- KRM 系列
- KR3 系列
- LJA 系列
- LLL 系列
- LJM 系列
- LLR 系列
- 警告 / 注意事项

GRM 系列温度补偿型品名列表

(→ ■ 1.6×0.8mm)

T 最大值	额定 电压	温度特 性代号	静电容量	公差	品名
0.9mm	100Vdc	CH	6.2pF	±0.05pF	GRM1882C2A6R2WA01#
				±0.1pF	GRM1882C2A6R2BA01#
				±0.25pF	GRM1882C2A6R2CA01#
				±0.5pF	GRM1882C2A6R2DA01#
			6.3pF	±0.05pF	GRM1882C2A6R3WA01#
				±0.1pF	GRM1882C2A6R3BA01#
				±0.25pF	GRM1882C2A6R3CA01#
				±0.5pF	GRM1882C2A6R3DA01#
			6.4pF	±0.05pF	GRM1882C2A6R4WA01#
				±0.1pF	GRM1882C2A6R4BA01#
				±0.25pF	GRM1882C2A6R4CA01#
				±0.5pF	GRM1882C2A6R4DA01#
			6.5pF	±0.05pF	GRM1882C2A6R5WA01#
				±0.1pF	GRM1882C2A6R5BA01#
				±0.25pF	GRM1882C2A6R5CA01#
				±0.5pF	GRM1882C2A6R5DA01#
			6.6pF	±0.05pF	GRM1882C2A6R6WA01#
				±0.1pF	GRM1882C2A6R6BA01#
				±0.25pF	GRM1882C2A6R6CA01#
				±0.5pF	GRM1882C2A6R6DA01#
			6.7pF	±0.05pF	GRM1882C2A6R7WA01#
				±0.1pF	GRM1882C2A6R7BA01#
				±0.25pF	GRM1882C2A6R7CA01#
				±0.5pF	GRM1882C2A6R7DA01#
			6.8pF	±0.05pF	GRM1882C2A6R8WA01#
				±0.1pF	GRM1882C2A6R8BA01#
				±0.25pF	GRM1882C2A6R8CA01#
				±0.5pF	GRM1882C2A6R8DA01#
			6.9pF	±0.05pF	GRM1882C2A6R9WA01#
				±0.1pF	GRM1882C2A6R9BA01#
				±0.25pF	GRM1882C2A6R9CA01#
				±0.5pF	GRM1882C2A6R9DA01#
			7.0pF	±0.05pF	GRM1882C2A7R0WA01#
				±0.1pF	GRM1882C2A7R0BA01#
				±0.25pF	GRM1882C2A7R0CA01#
				±0.5pF	GRM1882C2A7R0DA01#
			7.1pF	±0.05pF	GRM1882C2A7R1WA01#
				±0.1pF	GRM1882C2A7R1BA01#
				±0.25pF	GRM1882C2A7R1CA01#
				±0.5pF	GRM1882C2A7R1DA01#
			7.2pF	±0.05pF	GRM1882C2A7R2WA01#
				±0.1pF	GRM1882C2A7R2BA01#
				±0.25pF	GRM1882C2A7R2CA01#
				±0.5pF	GRM1882C2A7R2DA01#
			7.3pF	±0.05pF	GRM1882C2A7R3WA01#
				±0.1pF	GRM1882C2A7R3BA01#
				±0.25pF	GRM1882C2A7R3CA01#
				±0.5pF	GRM1882C2A7R3DA01#
			7.4pF	±0.05pF	GRM1882C2A7R4WA01#
				±0.1pF	GRM1882C2A7R4BA01#
				±0.25pF	GRM1882C2A7R4CA01#
				±0.5pF	GRM1882C2A7R4DA01#
			7.5pF	±0.05pF	GRM1882C2A7R5WA01#
				±0.1pF	GRM1882C2A7R5BA01#

T 最大值	额定 电压	温度特 性代号	静电容量	公差	品名
0.9mm	100Vdc	CH	7.5pF	±0.25pF	GRM1882C2A7R5CA01#
				±0.5pF	GRM1882C2A7R5DA01#
			7.6pF	±0.05pF	GRM1882C2A7R6WA01#
				±0.1pF	GRM1882C2A7R6BA01#
				±0.25pF	GRM1882C2A7R6CA01#
			7.7pF	±0.05pF	GRM1882C2A7R7WA01#
				±0.1pF	GRM1882C2A7R7BA01#
				±0.25pF	GRM1882C2A7R7CA01#
			7.8pF	±0.05pF	GRM1882C2A7R8WA01#
				±0.1pF	GRM1882C2A7R8BA01#
				±0.25pF	GRM1882C2A7R8CA01#
			7.9pF	±0.05pF	GRM1882C2A7R9WA01#
				±0.1pF	GRM1882C2A7R9BA01#
				±0.25pF	GRM1882C2A7R9CA01#
			8.0pF	±0.05pF	GRM1882C2A8R0WA01#
				±0.1pF	GRM1882C2A8R0BA01#
				±0.25pF	GRM1882C2A8R0CA01#
			8.1pF	±0.05pF	GRM1882C2A8R1WA01#
				±0.1pF	GRM1882C2A8R1BA01#
				±0.25pF	GRM1882C2A8R1CA01#
			8.2pF	±0.05pF	GRM1882C2A8R2WA01#
				±0.1pF	GRM1882C2A8R2BA01#
				±0.25pF	GRM1882C2A8R2CA01#
			8.3pF	±0.05pF	GRM1882C2A8R3WA01#
				±0.1pF	GRM1882C2A8R3BA01#
				±0.25pF	GRM1882C2A8R3CA01#
			8.4pF	±0.05pF	GRM1882C2A8R4WA01#
				±0.1pF	GRM1882C2A8R4BA01#
				±0.25pF	GRM1882C2A8R4CA01#
			8.5pF	±0.05pF	GRM1882C2A8R5WA01#
				±0.1pF	GRM1882C2A8R5BA01#
				±0.25pF	GRM1882C2A8R5CA01#
			8.6pF	±0.05pF	GRM1882C2A8R6WA01#
				±0.1pF	GRM1882C2A8R6BA01#
				±0.25pF	GRM1882C2A8R6CA01#
			8.7pF	±0.05pF	GRM1882C2A8R7WA01#
				±0.1pF	GRM1882C2A8R7BA01#
				±0.25pF	GRM1882C2A8R7CA01#
			8.8pF	±0.05pF	GRM1882C2A8R8WA01#
				±0.1pF	GRM1882C2A8R8BA01#
				±0.25pF	GRM1882C2A8R8CA01#

品名 # 表示包装规格代码。

GRM 系列
GJM 系列
GMA 系列
GMD 系列
GQM 系列
GRJ 系列
GR3 系列
KRM 系列
KR3 系列
LLA 系列
LLL 系列
LLM 系列
LLR 系列
警告/注意事项

GRM 系列温度补偿型品名列表

(→ ■ 1.6×0.8mm)

T 最大值	额定 电压	温度特 性代号	静电容量	公差	品名
0.9mm	100Vdc	CH	8.9pF	±0.05pF	GRM1882C2A8R9WA01#
				±0.1pF	GRM1882C2A8R9BA01#
				±0.25pF	GRM1882C2A8R9CA01#
				±0.5pF	GRM1882C2A8R9DA01#
			9.0pF	±0.05pF	GRM1882C2A9R0WA01#
				±0.1pF	GRM1882C2A9R0BA01#
				±0.25pF	GRM1882C2A9R0CA01#
				±0.5pF	GRM1882C2A9R0DA01#
			9.1pF	±0.05pF	GRM1882C2A9R1WA01#
				±0.1pF	GRM1882C2A9R1BA01#
				±0.25pF	GRM1882C2A9R1CA01#
				±0.5pF	GRM1882C2A9R1DA01#
			9.2pF	±0.05pF	GRM1882C2A9R2WA01#
				±0.1pF	GRM1882C2A9R2BA01#
				±0.25pF	GRM1882C2A9R2CA01#
				±0.5pF	GRM1882C2A9R2DA01#
			9.3pF	±0.05pF	GRM1882C2A9R3WA01#
				±0.1pF	GRM1882C2A9R3BA01#
				±0.25pF	GRM1882C2A9R3CA01#
			9.4pF	±0.05pF	GRM1882C2A9R4WA01#
				±0.1pF	GRM1882C2A9R4BA01#
				±0.25pF	GRM1882C2A9R4CA01#
			9.5pF	±0.05pF	GRM1882C2A9R5WA01#
				±0.1pF	GRM1882C2A9R5BA01#
				±0.25pF	GRM1882C2A9R5CA01#
			9.6pF	±0.05pF	GRM1882C2A9R6WA01#
				±0.1pF	GRM1882C2A9R6BA01#
				±0.25pF	GRM1882C2A9R6CA01#
				±0.5pF	GRM1882C2A9R6DA01#
			9.7pF	±0.05pF	GRM1882C2A9R7WA01#
				±0.1pF	GRM1882C2A9R7BA01#
				±0.25pF	GRM1882C2A9R7CA01#
			9.8pF	±0.05pF	GRM1882C2A9R8WA01#
				±0.1pF	GRM1882C2A9R8BA01#
				±0.25pF	GRM1882C2A9R8CA01#
				±0.5pF	GRM1882C2A9R8DA01#
			9.9pF	±0.05pF	GRM1882C2A9R9WA01#
				±0.1pF	GRM1882C2A9R9BA01#
				±0.25pF	GRM1882C2A9R9CA01#
				±0.5pF	GRM1882C2A9R9DA01#
			10pF	±5%	GRM1882C2A100JA01#
			12pF	±5%	GRM1882C2A120JA01#
			15pF	±5%	GRM1882C2A150JA01#
			18pF	±5%	GRM1882C2A180JA01#
			22pF	±5%	GRM1882C2A220JA01#
			27pF	±5%	GRM1882C2A270JA01#
			33pF	±5%	GRM1882C2A330JA01#
			39pF	±5%	GRM1882C2A390JA01#
			47pF	±5%	GRM1882C2A470JA01#
			56pF	±5%	GRM1882C2A560JA01#

T 最大值	额定 电压	温度特 性代号	静电容量	公差	品名
0.9mm	100Vdc	CH	68pF	±5%	GRM1882C2A680JA01#
				±5%	GRM1882C2A820JA01#
			82pF	±5%	GRM1882C2A101JA01#
				±5%	GRM1882C2A121JA01#
			100pF	±5%	GRM1882C2A151JA01#
				±5%	GRM1882C2A181JA01#
			120pF	±5%	GRM1882C2A221JA01#
				±5%	GRM1882C2A271JA01#
			150pF	±5%	GRM1882C2A331JA01#
				±5%	GRM1882C2A391JA01#
			180pF	±5%	GRM1882C2A471JA01#
				±5%	GRM1882C2A561JA01#
			220pF	±5%	GRM1882C2A681JA01#
				±5%	GRM1882C2A821JA01#
			270pF	±5%	GRM1882C2A102JA01#
				±5%	GRM1882C2A122JA01#
			330pF	±5%	GRM1882C2A152JA01#
				±5%	GRM1882C2A182JA01#
			390pF	±5%	GRM1885C1HR50WA01#
				±5%	GRM1885C1HR50BA01#
			470pF	±5%	GRM1885C1HR60WA01#
				±5%	GRM1885C1HR60BA01#
			560pF	±5%	GRM1885C1HR70WA01#
				±5%	GRM1885C1HR70BA01#
			680pF	±5%	GRM1885C1HR80WA01#
				±5%	GRM1885C1HR80BA01#
			820pF	±5%	GRM1885C1HR90WA01#
				±5%	GRM1885C1HR90BA01#
			1000pF	±5%	GRM1885C1H1R0WA01#
				±5%	GRM1885C1H1R0BA01#
			1200pF	±5%	GRM1885C1H1R0CA01#
				±5%	GRM1885C1H1R1WA01#
1500pF	±5%	GRM1885C1H1R1BA01#			
	±5%	GRM1885C1H1R1CA01#			
0.50pF	±0.05pF	GRM1885C1H1R2WA01#			
	±0.1pF	GRM1885C1H1R2BA01#			
0.60pF	±0.05pF	GRM1885C1H1R2CA01#			
	±0.1pF	GRM1885C1H1R3WA01#			
0.70pF	±0.05pF	GRM1885C1H1R3BA01#			
	±0.1pF	GRM1885C1H1R3CA01#			
0.80pF	±0.05pF	GRM1885C1H1R4WA01#			
	±0.1pF	GRM1885C1H1R4BA01#			
0.90pF	±0.05pF	GRM1885C1H1R4CA01#			
	±0.1pF	GRM1885C1H1R5WA01#			
1.0pF	±0.05pF	GRM1885C1H1R5BA01#			
	±0.1pF	GRM1885C1H1R5CA01#			
1.1pF	±0.05pF	GRM1885C1H1R6WA01#			
	±0.1pF	GRM1885C1H1R6BA01#			
1.2pF	±0.05pF	GRM1885C1H1R6CA01#			
	±0.1pF	GRM1885C1H1R7WA01#			
1.3pF	±0.05pF	GRM1885C1H1R7BA01#			
	±0.1pF	GRM1885C1H1R7CA01#			
1.4pF	±0.05pF	GRM1885C1H1R8WA01#			
	±0.1pF	GRM1885C1H1R8BA01#			
1.5pF	±0.05pF	GRM1885C1H1R8CA01#			
	±0.1pF	GRM1885C1H1R8WA01#			
1.6pF	±0.05pF	GRM1885C1H1R8BA01#			
	±0.1pF	GRM1885C1H1R8CA01#			
1.7pF	±0.05pF	GRM1885C1H1R8WA01#			
	±0.1pF	GRM1885C1H1R8BA01#			
1.8pF	±0.05pF	GRM1885C1H1R8CA01#			
	±0.1pF	GRM1885C1H1R8CA01#			

品名 # 表示包装规格代码。

- GRM 系列
- GJM 系列
- GMA 系列
- GMD 系列
- GQM 系列
- GRJ 系列
- GR3 系列
- KRM 系列
- KR3 系列
- LJA 系列
- LLL 系列
- LJM 系列
- LLR 系列
- 警告 / 注意事项

GRM 系列温度补偿型品名列表

(→ ■ 1.6×0.8mm)

T 最大值	额定 电压	温度特 性代号	静电容量	公差	品名
0.9mm	50Vdc	C0G	1.9pF	±0.05pF	GRM1885C1H1R9WA01#
				±0.1pF	GRM1885C1H1R9BA01#
				±0.25pF	GRM1885C1H1R9CA01#
			2.0pF	±0.05pF	GRM1885C1H2R0WA01#
				±0.1pF	GRM1885C1H2R0BA01#
				±0.25pF	GRM1885C1H2R0CA01#
			2.1pF	±0.05pF	GRM1885C1H2R1WA01#
				±0.1pF	GRM1885C1H2R1BA01#
				±0.25pF	GRM1885C1H2R1CA01#
			2.2pF	±0.05pF	GRM1885C1H2R2WA01#
				±0.1pF	GRM1885C1H2R2BA01#
				±0.25pF	GRM1885C1H2R2CA01#
			2.3pF	±0.05pF	GRM1885C1H2R3WA01#
				±0.1pF	GRM1885C1H2R3BA01#
				±0.25pF	GRM1885C1H2R3CA01#
			2.4pF	±0.05pF	GRM1885C1H2R4WA01#
				±0.1pF	GRM1885C1H2R4BA01#
				±0.25pF	GRM1885C1H2R4CA01#
			2.5pF	±0.05pF	GRM1885C1H2R5WA01#
				±0.1pF	GRM1885C1H2R5BA01#
				±0.25pF	GRM1885C1H2R5CA01#
			2.6pF	±0.05pF	GRM1885C1H2R6WA01#
				±0.1pF	GRM1885C1H2R6BA01#
				±0.25pF	GRM1885C1H2R6CA01#
			2.7pF	±0.05pF	GRM1885C1H2R7WA01#
				±0.1pF	GRM1885C1H2R7BA01#
				±0.25pF	GRM1885C1H2R7CA01#
			2.8pF	±0.05pF	GRM1885C1H2R8WA01#
				±0.1pF	GRM1885C1H2R8BA01#
				±0.25pF	GRM1885C1H2R8CA01#
			2.9pF	±0.05pF	GRM1885C1H2R9WA01#
				±0.1pF	GRM1885C1H2R9BA01#
				±0.25pF	GRM1885C1H2R9CA01#
			3.0pF	±0.05pF	GRM1885C1H3R0WA01#
				±0.1pF	GRM1885C1H3R0BA01#
				±0.25pF	GRM1885C1H3R0CA01#
			3.1pF	±0.05pF	GRM1885C1H3R1WA01#
				±0.1pF	GRM1885C1H3R1BA01#
				±0.25pF	GRM1885C1H3R1CA01#
			3.2pF	±0.05pF	GRM1885C1H3R2WA01#
				±0.1pF	GRM1885C1H3R2BA01#
				±0.25pF	GRM1885C1H3R2CA01#
			3.3pF	±0.05pF	GRM1885C1H3R3WA01#
				±0.1pF	GRM1885C1H3R3BA01#
				±0.25pF	GRM1885C1H3R3CA01#
			3.4pF	±0.05pF	GRM1885C1H3R4WA01#
				±0.1pF	GRM1885C1H3R4BA01#
				±0.25pF	GRM1885C1H3R4CA01#
3.5pF	±0.05pF	GRM1885C1H3R5WA01#			
	±0.1pF	GRM1885C1H3R5BA01#			
	±0.25pF	GRM1885C1H3R5CA01#			
3.6pF	±0.05pF	GRM1885C1H3R6WA01#			
	±0.1pF	GRM1885C1H3R6BA01#			
	±0.25pF	GRM1885C1H3R6CA01#			

T 最大值	额定 电压	温度特 性代号	静电容量	公差	品名
0.9mm	50Vdc	C0G	3.7pF	±0.05pF	GRM1885C1H3R7WA01#
				±0.1pF	GRM1885C1H3R7BA01#
				±0.25pF	GRM1885C1H3R7CA01#
			3.8pF	±0.05pF	GRM1885C1H3R8WA01#
				±0.1pF	GRM1885C1H3R8BA01#
				±0.25pF	GRM1885C1H3R8CA01#
			3.9pF	±0.05pF	GRM1885C1H3R9WA01#
				±0.1pF	GRM1885C1H3R9BA01#
				±0.25pF	GRM1885C1H3R9CA01#
			4.0pF	±0.05pF	GRM1885C1H4R0WA01#
				±0.1pF	GRM1885C1H4R0BA01#
				±0.25pF	GRM1885C1H4R0CA01#
			4.1pF	±0.05pF	GRM1885C1H4R1WA01#
				±0.1pF	GRM1885C1H4R1BA01#
				±0.25pF	GRM1885C1H4R1CA01#
			4.2pF	±0.05pF	GRM1885C1H4R2WA01#
				±0.1pF	GRM1885C1H4R2BA01#
				±0.25pF	GRM1885C1H4R2CA01#
			4.3pF	±0.05pF	GRM1885C1H4R3WA01#
				±0.1pF	GRM1885C1H4R3BA01#
				±0.25pF	GRM1885C1H4R3CA01#
			4.4pF	±0.05pF	GRM1885C1H4R4WA01#
				±0.1pF	GRM1885C1H4R4BA01#
				±0.25pF	GRM1885C1H4R4CA01#
			4.5pF	±0.05pF	GRM1885C1H4R5WA01#
				±0.1pF	GRM1885C1H4R5BA01#
				±0.25pF	GRM1885C1H4R5CA01#
			4.6pF	±0.05pF	GRM1885C1H4R6WA01#
				±0.1pF	GRM1885C1H4R6BA01#
				±0.25pF	GRM1885C1H4R6CA01#
			4.7pF	±0.05pF	GRM1885C1H4R7WA01#
				±0.1pF	GRM1885C1H4R7BA01#
				±0.25pF	GRM1885C1H4R7CA01#
			4.8pF	±0.05pF	GRM1885C1H4R8WA01#
				±0.1pF	GRM1885C1H4R8BA01#
				±0.25pF	GRM1885C1H4R8CA01#
			4.9pF	±0.05pF	GRM1885C1H4R9WA01#
				±0.1pF	GRM1885C1H4R9BA01#
				±0.25pF	GRM1885C1H4R9CA01#
			5.0pF	±0.05pF	GRM1885C1H5R0WA01#
				±0.1pF	GRM1885C1H5R0BA01#
				±0.25pF	GRM1885C1H5R0CA01#
			5.1pF	±0.05pF	GRM1885C1H5R1WA01#
				±0.1pF	GRM1885C1H5R1BA01#
				±0.25pF	GRM1885C1H5R1CA01#
			5.2pF	±0.05pF	GRM1885C1H5R2WA01#
				±0.1pF	GRM1885C1H5R2BA01#
				±0.25pF	GRM1885C1H5R2CA01#
5.3pF	±0.05pF	GRM1885C1H5R3WA01#			
	±0.1pF	GRM1885C1H5R3BA01#			
	±0.25pF	GRM1885C1H5R3CA01#			
5.3pF	±0.05pF	GRM1885C1H5R3DA01#			
	±0.1pF	GRM1885C1H5R3BA01#			
	±0.25pF	GRM1885C1H5R3CA01#			
5.3pF	±0.05pF	GRM1885C1H5R3DA01#			
	±0.1pF	GRM1885C1H5R3BA01#			
	±0.25pF	GRM1885C1H5R3CA01#			

品名 # 表示包装规格代码。

GRM 系列
GJM 系列
GMA 系列
GMD 系列
GQM 系列
GRJ 系列
GR3 系列
KRM 系列
KRP3 系列
LLA 系列
LLL 系列
LLM 系列
LLR 系列
警告/注意事项

GRM 系列温度补偿型品名列表

(→ ■ 1.6×0.8mm)

T 最大值	额定 电压	温度特 性代号	静电容量	公差	品名
0.9mm	50Vdc	C0G	5.4pF	±0.05pF	GRM1885C1H5R4WA01#
				±0.1pF	GRM1885C1H5R4BA01#
				±0.25pF	GRM1885C1H5R4CA01#
				±0.5pF	GRM1885C1H5R4DA01#
			5.5pF	±0.05pF	GRM1885C1H5R5WA01#
				±0.1pF	GRM1885C1H5R5BA01#
				±0.25pF	GRM1885C1H5R5CA01#
				±0.5pF	GRM1885C1H5R5DA01#
			5.6pF	±0.05pF	GRM1885C1H5R6WA01#
				±0.1pF	GRM1885C1H5R6BA01#
				±0.25pF	GRM1885C1H5R6CA01#
				±0.5pF	GRM1885C1H5R6DA01#
			5.7pF	±0.05pF	GRM1885C1H5R7WA01#
				±0.1pF	GRM1885C1H5R7BA01#
				±0.25pF	GRM1885C1H5R7CA01#
				±0.5pF	GRM1885C1H5R7DA01#
			5.8pF	±0.05pF	GRM1885C1H5R8WA01#
				±0.1pF	GRM1885C1H5R8BA01#
				±0.25pF	GRM1885C1H5R8CA01#
				±0.5pF	GRM1885C1H5R8DA01#
			5.9pF	±0.05pF	GRM1885C1H5R9WA01#
				±0.1pF	GRM1885C1H5R9BA01#
				±0.25pF	GRM1885C1H5R9CA01#
				±0.5pF	GRM1885C1H5R9DA01#
			6.0pF	±0.05pF	GRM1885C1H6R0WA01#
				±0.1pF	GRM1885C1H6R0BA01#
				±0.25pF	GRM1885C1H6R0CA01#
				±0.5pF	GRM1885C1H6R0DA01#
			6.1pF	±0.05pF	GRM1885C1H6R1WA01#
				±0.1pF	GRM1885C1H6R1BA01#
				±0.25pF	GRM1885C1H6R1CA01#
				±0.5pF	GRM1885C1H6R1DA01#
			6.2pF	±0.05pF	GRM1885C1H6R2WA01#
				±0.1pF	GRM1885C1H6R2BA01#
				±0.25pF	GRM1885C1H6R2CA01#
				±0.5pF	GRM1885C1H6R2DA01#
			6.3pF	±0.05pF	GRM1885C1H6R3WA01#
				±0.1pF	GRM1885C1H6R3BA01#
				±0.25pF	GRM1885C1H6R3CA01#
				±0.5pF	GRM1885C1H6R3DA01#
			6.4pF	±0.05pF	GRM1885C1H6R4WA01#
				±0.1pF	GRM1885C1H6R4BA01#
				±0.25pF	GRM1885C1H6R4CA01#
				±0.5pF	GRM1885C1H6R4DA01#
			6.5pF	±0.05pF	GRM1885C1H6R5WA01#
				±0.1pF	GRM1885C1H6R5BA01#
				±0.25pF	GRM1885C1H6R5CA01#
				±0.5pF	GRM1885C1H6R5DA01#
			6.6pF	±0.05pF	GRM1885C1H6R6WA01#
				±0.1pF	GRM1885C1H6R6BA01#
				±0.25pF	GRM1885C1H6R6CA01#
				±0.5pF	GRM1885C1H6R6DA01#
			6.7pF	±0.05pF	GRM1885C1H6R7WA01#
				±0.1pF	GRM1885C1H6R7BA01#

T 最大值	额定 电压	温度特 性代号	静电容量	公差	品名
0.9mm	50Vdc	C0G	6.7pF	±0.25pF	GRM1885C1H6R7CA01#
				±0.5pF	GRM1885C1H6R7DA01#
			6.8pF	±0.05pF	GRM1885C1H6R8WA01#
				±0.1pF	GRM1885C1H6R8BA01#
				±0.25pF	GRM1885C1H6R8CA01#
			6.9pF	±0.05pF	GRM1885C1H6R9WA01#
				±0.1pF	GRM1885C1H6R9BA01#
				±0.25pF	GRM1885C1H6R9CA01#
			7.0pF	±0.05pF	GRM1885C1H7R0WA01#
				±0.1pF	GRM1885C1H7R0BA01#
				±0.25pF	GRM1885C1H7R0CA01#
			7.1pF	±0.05pF	GRM1885C1H7R1WA01#
				±0.1pF	GRM1885C1H7R1BA01#
				±0.25pF	GRM1885C1H7R1CA01#
			7.2pF	±0.05pF	GRM1885C1H7R2WA01#
				±0.1pF	GRM1885C1H7R2BA01#
				±0.25pF	GRM1885C1H7R2CA01#
			7.3pF	±0.05pF	GRM1885C1H7R3WA01#
				±0.1pF	GRM1885C1H7R3BA01#
				±0.25pF	GRM1885C1H7R3CA01#
			7.4pF	±0.05pF	GRM1885C1H7R4WA01#
				±0.1pF	GRM1885C1H7R4BA01#
				±0.25pF	GRM1885C1H7R4CA01#
			7.5pF	±0.05pF	GRM1885C1H7R5WA01#
				±0.1pF	GRM1885C1H7R5BA01#
				±0.25pF	GRM1885C1H7R5CA01#
			7.6pF	±0.05pF	GRM1885C1H7R6WA01#
				±0.1pF	GRM1885C1H7R6BA01#
				±0.25pF	GRM1885C1H7R6CA01#
			7.7pF	±0.05pF	GRM1885C1H7R7WA01#
				±0.1pF	GRM1885C1H7R7BA01#
				±0.25pF	GRM1885C1H7R7CA01#
			7.8pF	±0.05pF	GRM1885C1H7R8WA01#
				±0.1pF	GRM1885C1H7R8BA01#
				±0.25pF	GRM1885C1H7R8CA01#
			7.9pF	±0.05pF	GRM1885C1H7R9WA01#
				±0.1pF	GRM1885C1H7R9BA01#
				±0.25pF	GRM1885C1H7R9CA01#
			8.0pF	±0.05pF	GRM1885C1H8R0WA01#
				±0.1pF	GRM1885C1H8R0BA01#
				±0.25pF	GRM1885C1H8R0CA01#

品名 # 表示包装规格代码。

- GRM 系列
- GJM 系列
- GMA 系列
- GMD 系列
- GQM 系列
- GRJ 系列
- GR3 系列
- KRM 系列
- KR3 系列
- LJA 系列
- LLL 系列
- LJM 系列
- LLR 系列
- 警告 / 注意事項

GRM 系列温度补偿型品名列表

(→ ■ 1.6×0.8mm)

T 最大值	额定 电压	温度特 性代号	静电容量	公差	品名
0.9mm	50Vdc	C0G	8.1pF	±0.05pF	GRM1885C1H8R1WA01#
				±0.1pF	GRM1885C1H8R1BA01#
				±0.25pF	GRM1885C1H8R1CA01#
				±0.5pF	GRM1885C1H8R1DA01#
			8.2pF	±0.05pF	GRM1885C1H8R2WA01#
				±0.1pF	GRM1885C1H8R2BA01#
				±0.25pF	GRM1885C1H8R2CA01#
				±0.5pF	GRM1885C1H8R2DA01#
			8.3pF	±0.05pF	GRM1885C1H8R3WA01#
				±0.1pF	GRM1885C1H8R3BA01#
				±0.25pF	GRM1885C1H8R3CA01#
				±0.5pF	GRM1885C1H8R3DA01#
			8.4pF	±0.05pF	GRM1885C1H8R4WA01#
				±0.1pF	GRM1885C1H8R4BA01#
				±0.25pF	GRM1885C1H8R4CA01#
				±0.5pF	GRM1885C1H8R4DA01#
			8.5pF	±0.05pF	GRM1885C1H8R5WA01#
				±0.1pF	GRM1885C1H8R5BA01#
				±0.25pF	GRM1885C1H8R5CA01#
				±0.5pF	GRM1885C1H8R5DA01#
			8.6pF	±0.05pF	GRM1885C1H8R6WA01#
				±0.1pF	GRM1885C1H8R6BA01#
				±0.25pF	GRM1885C1H8R6CA01#
				±0.5pF	GRM1885C1H8R6DA01#
			8.7pF	±0.05pF	GRM1885C1H8R7WA01#
				±0.1pF	GRM1885C1H8R7BA01#
				±0.25pF	GRM1885C1H8R7CA01#
				±0.5pF	GRM1885C1H8R7DA01#
			8.8pF	±0.05pF	GRM1885C1H8R8WA01#
				±0.1pF	GRM1885C1H8R8BA01#
				±0.25pF	GRM1885C1H8R8CA01#
				±0.5pF	GRM1885C1H8R8DA01#
			8.9pF	±0.05pF	GRM1885C1H8R9WA01#
				±0.1pF	GRM1885C1H8R9BA01#
				±0.25pF	GRM1885C1H8R9CA01#
				±0.5pF	GRM1885C1H8R9DA01#
			9.0pF	±0.05pF	GRM1885C1H9R0WA01#
				±0.1pF	GRM1885C1H9R0BA01#
				±0.25pF	GRM1885C1H9R0CA01#
				±0.5pF	GRM1885C1H9R0DA01#
			9.1pF	±0.05pF	GRM1885C1H9R1WA01#
				±0.1pF	GRM1885C1H9R1BA01#
				±0.25pF	GRM1885C1H9R1CA01#
				±0.5pF	GRM1885C1H9R1DA01#
			9.2pF	±0.05pF	GRM1885C1H9R2WA01#
				±0.1pF	GRM1885C1H9R2BA01#
				±0.25pF	GRM1885C1H9R2CA01#
				±0.5pF	GRM1885C1H9R2DA01#
			9.3pF	±0.05pF	GRM1885C1H9R3WA01#
				±0.1pF	GRM1885C1H9R3BA01#
				±0.25pF	GRM1885C1H9R3CA01#
				±0.5pF	GRM1885C1H9R3DA01#
			9.4pF	±0.05pF	GRM1885C1H9R4WA01#
				±0.1pF	GRM1885C1H9R4BA01#

T 最大值	额定 电压	温度特 性代号	静电容量	公差	品名
0.9mm	50Vdc	C0G	9.4pF	±0.25pF	GRM1885C1H9R4CA01#
				±0.5pF	GRM1885C1H9R4DA01#
			9.5pF	±0.05pF	GRM1885C1H9R5WA01#
				±0.1pF	GRM1885C1H9R5BA01#
				±0.25pF	GRM1885C1H9R5CA01#
			9.6pF	±0.5pF	GRM1885C1H9R5DA01#
				±0.05pF	GRM1885C1H9R6WA01#
				±0.1pF	GRM1885C1H9R6BA01#
			9.7pF	±0.25pF	GRM1885C1H9R6CA01#
				±0.5pF	GRM1885C1H9R6DA01#
				±0.05pF	GRM1885C1H9R7WA01#
			9.8pF	±0.1pF	GRM1885C1H9R7BA01#
				±0.25pF	GRM1885C1H9R7CA01#
				±0.5pF	GRM1885C1H9R7DA01#
			9.9pF	±0.05pF	GRM1885C1H9R8WA01#
				±0.1pF	GRM1885C1H9R8BA01#
				±0.25pF	GRM1885C1H9R8CA01#
			10pF	±0.5pF	GRM1885C1H9R8DA01#
				±0.05pF	GRM1885C1H9R9WA01#
				±0.1pF	GRM1885C1H9R9BA01#
			12pF	±0.25pF	GRM1885C1H9R9CA01#
				±0.5pF	GRM1885C1H9R9DA01#
				±5%	GRM1885C1H100JA01#
			15pF	±5%	GRM1885C1H120JA01#
				±5%	GRM1885C1H150JA01#
				±5%	GRM1885C1H180JA01#
			18pF	±5%	GRM1885C1H220JA01#
				±5%	GRM1885C1H270JA01#
				±5%	GRM1885C1H330JA01#
			22pF	±5%	GRM1885C1H390JA01#
				±5%	GRM1885C1H470JA01#
				±5%	GRM1885C1H560JA01#
			27pF	±5%	GRM1885C1H680JA01#
				±5%	GRM1885C1H820JA01#
				±5%	GRM1885C1H101JA01#
			33pF	±5%	GRM1885C1H121JA01#
				±5%	GRM1885C1H151JA01#
				±5%	GRM1885C1H181JA01#
			39pF	±5%	GRM1885C1H221JA01#
				±5%	GRM1885C1H271JA01#
				±5%	GRM1885C1H331JA01#
			47pF	±5%	GRM1885C1H391JA01#
				±5%	GRM1885C1H471JA01#
				±5%	GRM1885C1H561JA01#
			56pF	±5%	GRM1885C1H681JA01#
				±5%	GRM1885C1H821JA01#
				±5%	GRM1885C1H102JA01#
			68pF	±5%	GRM1885C1H122JA01#
				±5%	GRM1885C1H152JA01#
				±5%	GRM1885C1H182JA01#
			82pF	±5%	GRM1885C1H222JA01#
				±5%	GRM1885C1H272JA01#
				±5%	GRM1885C1H332JA01#
			100pF	±5%	GRM1885C1H392JA01#
				±5%	GRM1885C1H472JA01#
				±5%	GRM1885C1H562JA01#
			120pF	±5%	GRM1885C1H682JA01#
				±5%	GRM1885C1H822JA01#
				±5%	GRM1885C1H102JA01#
			150pF	±5%	GRM1885C1H122JA01#
				±5%	GRM1885C1H152JA01#
				±5%	GRM1885C1H182JA01#
			180pF	±5%	GRM1885C1H222JA01#
				±5%	GRM1885C1H272JA01#
				±5%	GRM1885C1H332JA01#
			220pF	±5%	GRM1885C1H392JA01#
				±5%	GRM1885C1H472JA01#
				±5%	GRM1885C1H562JA01#
			270pF	±5%	GRM1885C1H682JA01#
				±5%	GRM1885C1H822JA01#
				±5%	GRM1885C1H102JA01#
			330pF	±5%	GRM1885C1H122JA01#
				±5%	GRM1885C1H152JA01#
				±5%	GRM1885C1H182JA01#
			390pF	±5%	GRM1885C1H222JA01#
				±5%	GRM1885C1H272JA01#
				±5%	GRM1885C1H332JA01#
			470pF	±5%	GRM1885C1H392JA01#
				±5%	GRM1885C1H472JA01#
				±5%	GRM1885C1H562JA01#
			560pF	±5%	GRM1885C1H682JA01#
				±5%	GRM1885C1H822JA01#
				±5%	GRM1885C1H102JA01#
			680pF	±5%	GRM1885C1H122JA01#
				±5%	GRM1885C1H152JA01#
				±5%	GRM1885C1H182JA01#
			820pF	±5%	GRM1885C1H222JA01#
				±5%	GRM1885C1H272JA01#
				±5%	GRM1885C1H332JA01#
			1000pF	±5%	GRM1885C1H392JA01#
				±5%	GRM1885C1H472JA01#
				±5%	GRM1885C1H562JA01#
			1200pF	±5%	GRM1885C1H682JA01#
				±5%	GRM1885C1H822JA01#
				±5%	GRM1885C1H102JA01#
			1500pF	±5%	GRM1885C1H122JA01#
				±5%	GRM1885C1H152JA01#
				±5%	GRM1885C1H182JA01#
			1800pF	±5%	GRM1885C1H222JA01#
				±5%	GRM1885C1H272JA01#
±5%	GRM1885C1H332JA01#				
2200pF	±5%	GRM1885C1H392JA01#			
	±5%	GRM1885C1H472JA01#			
	±5%	GRM1885C1H562JA01#			
2700pF	±5%	GRM1885C1H682JA01#			
	±5%	GRM1885C1H822JA01#			
	±5%	GRM1885C1H102JA01#			
3300pF	±5%	GRM1885C1H122JA01#			
	±5%	GRM1885C1H152JA01#			
	±5%	GRM1885C1H182JA01#			
3900pF	±5%	GRM1885C1H222JA01#			
	±5%	GRM1885C1H272JA01#			
	±5%	GRM1885C1H332JA01#			

品名 # 表示包装规格代码。

GRM 系列
GJM 系列
GMA 系列
GMD 系列
GQM 系列
GRJ 系列
GR3 系列
KRM 系列
KR3 系列
LLA 系列
LLL 系列
LLM 系列
LLR 系列
警告/注意事项

GRM 系列温度补偿型品名列表

(→ ■ 1.6×0.8mm)

T 最大值	额定 电压	温度特 性代号	静电容量	公差	品名	
0.9mm	50Vdc	COG	4700pF	±5%	GRM1885C1H472JA01#	
			5600pF	±5%	GRM1885C1H562JA01#	
			6800pF	±5%	GRM1885C1H682JA01#	
			8200pF	±5%	GRM1885C1H822JA01#	
			10000pF	±5%	GRM1885C1H103JA01#	
		CK	0.50pF	±0.05pF	GRM1884C1HR50WA01#	
				±0.1pF	GRM1884C1HR50BA01#	
			0.60pF	±0.05pF	GRM1884C1HR60WA01#	
				±0.1pF	GRM1884C1HR60BA01#	
			0.70pF	±0.05pF	GRM1884C1HR70WA01#	
				±0.1pF	GRM1884C1HR70BA01#	
			0.80pF	±0.05pF	GRM1884C1HR80WA01#	
				±0.1pF	GRM1884C1HR80BA01#	
			0.90pF	±0.05pF	GRM1884C1HR90WA01#	
				±0.1pF	GRM1884C1HR90BA01#	
			1.0pF	±0.05pF	GRM1884C1H1R0WA01#	
				±0.1pF	GRM1884C1H1R0BA01#	
				±0.25pF	GRM1884C1H1R0CA01#	
			1.1pF	±0.05pF	GRM1884C1H1R1WA01#	
				±0.1pF	GRM1884C1H1R1BA01#	
				±0.25pF	GRM1884C1H1R1CA01#	
			1.2pF	±0.05pF	GRM1884C1H1R2WA01#	
				±0.1pF	GRM1884C1H1R2BA01#	
				±0.25pF	GRM1884C1H1R2CA01#	
			1.3pF	±0.05pF	GRM1884C1H1R3WA01#	
				±0.1pF	GRM1884C1H1R3BA01#	
				±0.25pF	GRM1884C1H1R3CA01#	
			1.4pF	±0.05pF	GRM1884C1H1R4WA01#	
				±0.1pF	GRM1884C1H1R4BA01#	
				±0.25pF	GRM1884C1H1R4CA01#	
			1.5pF	±0.05pF	GRM1884C1H1R5WA01#	
				±0.1pF	GRM1884C1H1R5BA01#	
				±0.25pF	GRM1884C1H1R5CA01#	
			1.6pF	±0.05pF	GRM1884C1H1R6WA01#	
				±0.1pF	GRM1884C1H1R6BA01#	
				±0.25pF	GRM1884C1H1R6CA01#	
			1.7pF	±0.05pF	GRM1884C1H1R7WA01#	
				±0.1pF	GRM1884C1H1R7BA01#	
				±0.25pF	GRM1884C1H1R7CA01#	
			1.8pF	±0.05pF	GRM1884C1H1R8WA01#	
				±0.1pF	GRM1884C1H1R8BA01#	
				±0.25pF	GRM1884C1H1R8CA01#	
			1.9pF	±0.05pF	GRM1884C1H1R9WA01#	
				±0.1pF	GRM1884C1H1R9BA01#	
				±0.25pF	GRM1884C1H1R9CA01#	
			2.0pF	±0.05pF	GRM1884C1H2R0WA01#	
				±0.1pF	GRM1884C1H2R0BA01#	
				±0.25pF	GRM1884C1H2R0CA01#	
			CJ	2.1pF	±0.05pF	GRM1883C1H2R1WA01#
					±0.1pF	GRM1883C1H2R1BA01#
±0.25pF	GRM1883C1H2R1CA01#					
2.2pF	±0.05pF	GRM1883C1H2R2WA01#				
	±0.1pF	GRM1883C1H2R2BA01#				
	±0.25pF	GRM1883C1H2R2CA01#				

T 最大值	额定 电压	温度特 性代号	静电容量	公差	品名
0.9mm	50Vdc	CJ	2.3pF	±0.05pF	GRM1883C1H2R3WA01#
				±0.1pF	GRM1883C1H2R3BA01#
				±0.25pF	GRM1883C1H2R3CA01#
			2.4pF	±0.05pF	GRM1883C1H2R4WA01#
				±0.1pF	GRM1883C1H2R4BA01#
				±0.25pF	GRM1883C1H2R4CA01#
			2.5pF	±0.05pF	GRM1883C1H2R5WA01#
				±0.1pF	GRM1883C1H2R5BA01#
				±0.25pF	GRM1883C1H2R5CA01#
			2.6pF	±0.05pF	GRM1883C1H2R6WA01#
				±0.1pF	GRM1883C1H2R6BA01#
				±0.25pF	GRM1883C1H2R6CA01#
			2.7pF	±0.05pF	GRM1883C1H2R7WA01#
				±0.1pF	GRM1883C1H2R7BA01#
				±0.25pF	GRM1883C1H2R7CA01#
			2.8pF	±0.05pF	GRM1883C1H2R8WA01#
				±0.1pF	GRM1883C1H2R8BA01#
				±0.25pF	GRM1883C1H2R8CA01#
			2.9pF	±0.05pF	GRM1883C1H2R9WA01#
				±0.1pF	GRM1883C1H2R9BA01#
				±0.25pF	GRM1883C1H2R9CA01#
			3.0pF	±0.05pF	GRM1883C1H3R0WA01#
				±0.1pF	GRM1883C1H3R0BA01#
				±0.25pF	GRM1883C1H3R0CA01#
			3.1pF	±0.05pF	GRM1883C1H3R1WA01#
				±0.1pF	GRM1883C1H3R1BA01#
				±0.25pF	GRM1883C1H3R1CA01#
			3.2pF	±0.05pF	GRM1883C1H3R2WA01#
				±0.1pF	GRM1883C1H3R2BA01#
				±0.25pF	GRM1883C1H3R2CA01#
3.3pF	±0.05pF	GRM1883C1H3R3WA01#			
	±0.1pF	GRM1883C1H3R3BA01#			
	±0.25pF	GRM1883C1H3R3CA01#			
3.4pF	±0.05pF	GRM1883C1H3R4WA01#			
	±0.1pF	GRM1883C1H3R4BA01#			
	±0.25pF	GRM1883C1H3R4CA01#			
3.5pF	±0.05pF	GRM1883C1H3R5WA01#			
	±0.1pF	GRM1883C1H3R5BA01#			
	±0.25pF	GRM1883C1H3R5CA01#			
3.6pF	±0.05pF	GRM1883C1H3R6WA01#			
	±0.1pF	GRM1883C1H3R6BA01#			
	±0.25pF	GRM1883C1H3R6CA01#			
3.7pF	±0.05pF	GRM1883C1H3R7WA01#			
	±0.1pF	GRM1883C1H3R7BA01#			
	±0.25pF	GRM1883C1H3R7CA01#			
3.8pF	±0.05pF	GRM1883C1H3R8WA01#			
	±0.1pF	GRM1883C1H3R8BA01#			
	±0.25pF	GRM1883C1H3R8CA01#			
3.9pF	±0.05pF	GRM1883C1H3R9WA01#			
	±0.1pF	GRM1883C1H3R9BA01#			
	±0.25pF	GRM1883C1H3R9CA01#			
	CH	4.0pF	±0.05pF	GRM1882C1H4R0WA01#	
			±0.1pF	GRM1882C1H4R0BA01#	
			±0.25pF	GRM1882C1H4R0CA01#	

品名 # 表示包装规格代码。

- GRM 系列
- GJM 系列
- GMA 系列
- GMD 系列
- GQM 系列
- GRJ 系列
- GR3 系列
- KRM 系列
- KR3 系列
- LJA 系列
- LLL 系列
- LJM 系列
- LLR 系列
- 警告 / 注意事項

GRM 系列温度补偿型品名列表

(→ ■ 1.6×0.8mm)

T 最大值	额定 电压	温度特 性代号	静电容量	公差	品名
0.9mm	50Vdc	CH	4.1pF	±0.05pF	GRM1882C1H4R1WA01#
				±0.1pF	GRM1882C1H4R1BA01#
				±0.25pF	GRM1882C1H4R1CA01#
			4.2pF	±0.05pF	GRM1882C1H4R2WA01#
				±0.1pF	GRM1882C1H4R2BA01#
				±0.25pF	GRM1882C1H4R2CA01#
			4.3pF	±0.05pF	GRM1882C1H4R3WA01#
				±0.1pF	GRM1882C1H4R3BA01#
				±0.25pF	GRM1882C1H4R3CA01#
			4.4pF	±0.05pF	GRM1882C1H4R4WA01#
				±0.1pF	GRM1882C1H4R4BA01#
				±0.25pF	GRM1882C1H4R4CA01#
			4.5pF	±0.05pF	GRM1882C1H4R5WA01#
				±0.1pF	GRM1882C1H4R5BA01#
				±0.25pF	GRM1882C1H4R5CA01#
			4.6pF	±0.05pF	GRM1882C1H4R6WA01#
				±0.1pF	GRM1882C1H4R6BA01#
				±0.25pF	GRM1882C1H4R6CA01#
			4.7pF	±0.05pF	GRM1882C1H4R7WA01#
				±0.1pF	GRM1882C1H4R7BA01#
				±0.25pF	GRM1882C1H4R7CA01#
			4.8pF	±0.05pF	GRM1882C1H4R8WA01#
				±0.1pF	GRM1882C1H4R8BA01#
				±0.25pF	GRM1882C1H4R8CA01#
			4.9pF	±0.05pF	GRM1882C1H4R9WA01#
				±0.1pF	GRM1882C1H4R9BA01#
				±0.25pF	GRM1882C1H4R9CA01#
			5.0pF	±0.05pF	GRM1882C1H5R0WA01#
				±0.1pF	GRM1882C1H5R0BA01#
				±0.25pF	GRM1882C1H5R0CA01#
			5.1pF	±0.05pF	GRM1882C1H5R1WA01#
				±0.1pF	GRM1882C1H5R1BA01#
				±0.25pF	GRM1882C1H5R1CA01#
				±0.5pF	GRM1882C1H5R1DA01#
			5.2pF	±0.05pF	GRM1882C1H5R2WA01#
				±0.1pF	GRM1882C1H5R2BA01#
				±0.25pF	GRM1882C1H5R2CA01#
				±0.5pF	GRM1882C1H5R2DA01#
			5.3pF	±0.05pF	GRM1882C1H5R3WA01#
				±0.1pF	GRM1882C1H5R3BA01#
				±0.25pF	GRM1882C1H5R3CA01#
				±0.5pF	GRM1882C1H5R3DA01#
			5.4pF	±0.05pF	GRM1882C1H5R4WA01#
				±0.1pF	GRM1882C1H5R4BA01#
				±0.25pF	GRM1882C1H5R4CA01#
				±0.5pF	GRM1882C1H5R4DA01#
			5.5pF	±0.05pF	GRM1882C1H5R5WA01#
				±0.1pF	GRM1882C1H5R5BA01#
				±0.25pF	GRM1882C1H5R5CA01#
				±0.5pF	GRM1882C1H5R5DA01#
			5.6pF	±0.05pF	GRM1882C1H5R6WA01#
				±0.1pF	GRM1882C1H5R6BA01#
				±0.25pF	GRM1882C1H5R6CA01#
				±0.5pF	GRM1882C1H5R6DA01#

T 最大值	额定 电压	温度特 性代号	静电容量	公差	品名
0.9mm	50Vdc	CH	5.7pF	±0.05pF	GRM1882C1H5R7WA01#
				±0.1pF	GRM1882C1H5R7BA01#
				±0.25pF	GRM1882C1H5R7CA01#
				±0.5pF	GRM1882C1H5R7DA01#
			5.8pF	±0.05pF	GRM1882C1H5R8WA01#
				±0.1pF	GRM1882C1H5R8BA01#
				±0.25pF	GRM1882C1H5R8CA01#
				±0.5pF	GRM1882C1H5R8DA01#
			5.9pF	±0.05pF	GRM1882C1H5R9WA01#
				±0.1pF	GRM1882C1H5R9BA01#
				±0.25pF	GRM1882C1H5R9CA01#
				±0.5pF	GRM1882C1H5R9DA01#
			6.0pF	±0.05pF	GRM1882C1H6R0WA01#
				±0.1pF	GRM1882C1H6R0BA01#
				±0.25pF	GRM1882C1H6R0CA01#
				±0.5pF	GRM1882C1H6R0DA01#
			6.1pF	±0.05pF	GRM1882C1H6R1WA01#
				±0.1pF	GRM1882C1H6R1BA01#
				±0.25pF	GRM1882C1H6R1CA01#
				±0.5pF	GRM1882C1H6R1DA01#
			6.2pF	±0.05pF	GRM1882C1H6R2WA01#
				±0.1pF	GRM1882C1H6R2BA01#
				±0.25pF	GRM1882C1H6R2CA01#
				±0.5pF	GRM1882C1H6R2DA01#
			6.3pF	±0.05pF	GRM1882C1H6R3WA01#
				±0.1pF	GRM1882C1H6R3BA01#
				±0.25pF	GRM1882C1H6R3CA01#
				±0.5pF	GRM1882C1H6R3DA01#
			6.4pF	±0.05pF	GRM1882C1H6R4WA01#
				±0.1pF	GRM1882C1H6R4BA01#
				±0.25pF	GRM1882C1H6R4CA01#
				±0.5pF	GRM1882C1H6R4DA01#
			6.5pF	±0.05pF	GRM1882C1H6R5WA01#
				±0.1pF	GRM1882C1H6R5BA01#
				±0.25pF	GRM1882C1H6R5CA01#
				±0.5pF	GRM1882C1H6R5DA01#
			6.6pF	±0.05pF	GRM1882C1H6R6WA01#
				±0.1pF	GRM1882C1H6R6BA01#
				±0.25pF	GRM1882C1H6R6CA01#
				±0.5pF	GRM1882C1H6R6DA01#
			6.7pF	±0.05pF	GRM1882C1H6R7WA01#
				±0.1pF	GRM1882C1H6R7BA01#
				±0.25pF	GRM1882C1H6R7CA01#
				±0.5pF	GRM1882C1H6R7DA01#
			6.8pF	±0.05pF	GRM1882C1H6R8WA01#
				±0.1pF	GRM1882C1H6R8BA01#
				±0.25pF	GRM1882C1H6R8CA01#
				±0.5pF	GRM1882C1H6R8DA01#
			6.9pF	±0.05pF	GRM1882C1H6R9WA01#
				±0.1pF	GRM1882C1H6R9BA01#
				±0.25pF	GRM1882C1H6R9CA01#
				±0.5pF	GRM1882C1H6R9DA01#
			7.0pF	±0.05pF	GRM1882C1H7R0WA01#
				±0.1pF	GRM1882C1H7R0BA01#

品名 # 表示包装规格代码。

GRM 系列
GJM 系列
GMA 系列
GMD 系列
GQM 系列
GRJ 系列
GR3 系列
KRM 系列
KR3 系列
LLA 系列
LLL 系列
LLM 系列
LLR 系列
警告/注意事项

GRM 系列温度补偿型品名列表

(→ ■ 1.6×0.8mm)

T 最大值	额定 电压	温度特 性代号	静电容量	公差	品名
0.9mm	50Vdc	CH	7.0pF	±0.25pF	GRM1882C1H7R0CA01#
				±0.5pF	GRM1882C1H7R0DA01#
			7.1pF	±0.05pF	GRM1882C1H7R1WA01#
				±0.1pF	GRM1882C1H7R1BA01#
				±0.25pF	GRM1882C1H7R1CA01#
				±0.5pF	GRM1882C1H7R1DA01#
			7.2pF	±0.05pF	GRM1882C1H7R2WA01#
				±0.1pF	GRM1882C1H7R2BA01#
				±0.25pF	GRM1882C1H7R2CA01#
				±0.5pF	GRM1882C1H7R2DA01#
			7.3pF	±0.05pF	GRM1882C1H7R3WA01#
				±0.1pF	GRM1882C1H7R3BA01#
				±0.25pF	GRM1882C1H7R3CA01#
				±0.5pF	GRM1882C1H7R3DA01#
			7.4pF	±0.05pF	GRM1882C1H7R4WA01#
				±0.1pF	GRM1882C1H7R4BA01#
				±0.25pF	GRM1882C1H7R4CA01#
				±0.5pF	GRM1882C1H7R4DA01#
			7.5pF	±0.05pF	GRM1882C1H7R5WA01#
				±0.1pF	GRM1882C1H7R5BA01#
				±0.25pF	GRM1882C1H7R5CA01#
				±0.5pF	GRM1882C1H7R5DA01#
			7.6pF	±0.05pF	GRM1882C1H7R6WA01#
				±0.1pF	GRM1882C1H7R6BA01#
				±0.25pF	GRM1882C1H7R6CA01#
				±0.5pF	GRM1882C1H7R6DA01#
			7.7pF	±0.05pF	GRM1882C1H7R7WA01#
				±0.1pF	GRM1882C1H7R7BA01#
				±0.25pF	GRM1882C1H7R7CA01#
				±0.5pF	GRM1882C1H7R7DA01#
			7.8pF	±0.05pF	GRM1882C1H7R8WA01#
				±0.1pF	GRM1882C1H7R8BA01#
				±0.25pF	GRM1882C1H7R8CA01#
				±0.5pF	GRM1882C1H7R8DA01#
			7.9pF	±0.05pF	GRM1882C1H7R9WA01#
				±0.1pF	GRM1882C1H7R9BA01#
				±0.25pF	GRM1882C1H7R9CA01#
				±0.5pF	GRM1882C1H7R9DA01#
			8.0pF	±0.05pF	GRM1882C1H8R0WA01#
				±0.1pF	GRM1882C1H8R0BA01#
				±0.25pF	GRM1882C1H8R0CA01#
				±0.5pF	GRM1882C1H8R0DA01#
			8.1pF	±0.05pF	GRM1882C1H8R1WA01#
				±0.1pF	GRM1882C1H8R1BA01#
				±0.25pF	GRM1882C1H8R1CA01#
				±0.5pF	GRM1882C1H8R1DA01#
			8.2pF	±0.05pF	GRM1882C1H8R2WA01#
				±0.1pF	GRM1882C1H8R2BA01#
				±0.25pF	GRM1882C1H8R2CA01#
				±0.5pF	GRM1882C1H8R2DA01#
			8.3pF	±0.05pF	GRM1882C1H8R3WA01#
				±0.1pF	GRM1882C1H8R3BA01#
				±0.25pF	GRM1882C1H8R3CA01#
				±0.5pF	GRM1882C1H8R3DA01#

T 最大值	额定 电压	温度特 性代号	静电容量	公差	品名
0.9mm	50Vdc	CH	8.4pF	±0.05pF	GRM1882C1H8R4WA01#
				±0.1pF	GRM1882C1H8R4BA01#
				±0.25pF	GRM1882C1H8R4CA01#
				±0.5pF	GRM1882C1H8R4DA01#
			8.5pF	±0.05pF	GRM1882C1H8R5WA01#
				±0.1pF	GRM1882C1H8R5BA01#
				±0.25pF	GRM1882C1H8R5CA01#
				±0.5pF	GRM1882C1H8R5DA01#
			8.6pF	±0.05pF	GRM1882C1H8R6WA01#
				±0.1pF	GRM1882C1H8R6BA01#
				±0.25pF	GRM1882C1H8R6CA01#
				±0.5pF	GRM1882C1H8R6DA01#
			8.7pF	±0.05pF	GRM1882C1H8R7WA01#
				±0.1pF	GRM1882C1H8R7BA01#
				±0.25pF	GRM1882C1H8R7CA01#
				±0.5pF	GRM1882C1H8R7DA01#
			8.8pF	±0.05pF	GRM1882C1H8R8WA01#
				±0.1pF	GRM1882C1H8R8BA01#
				±0.25pF	GRM1882C1H8R8CA01#
				±0.5pF	GRM1882C1H8R8DA01#
			8.9pF	±0.05pF	GRM1882C1H8R9WA01#
				±0.1pF	GRM1882C1H8R9BA01#
				±0.25pF	GRM1882C1H8R9CA01#
				±0.5pF	GRM1882C1H8R9DA01#
			9.0pF	±0.05pF	GRM1882C1H9R0WA01#
				±0.1pF	GRM1882C1H9R0BA01#
				±0.25pF	GRM1882C1H9R0CA01#
				±0.5pF	GRM1882C1H9R0DA01#
			9.1pF	±0.05pF	GRM1882C1H9R1WA01#
				±0.1pF	GRM1882C1H9R1BA01#
				±0.25pF	GRM1882C1H9R1CA01#
				±0.5pF	GRM1882C1H9R1DA01#
			9.2pF	±0.05pF	GRM1882C1H9R2WA01#
				±0.1pF	GRM1882C1H9R2BA01#
				±0.25pF	GRM1882C1H9R2CA01#
				±0.5pF	GRM1882C1H9R2DA01#
			9.3pF	±0.05pF	GRM1882C1H9R3WA01#
				±0.1pF	GRM1882C1H9R3BA01#
				±0.25pF	GRM1882C1H9R3CA01#
				±0.5pF	GRM1882C1H9R3DA01#
			9.4pF	±0.05pF	GRM1882C1H9R4WA01#
				±0.1pF	GRM1882C1H9R4BA01#
±0.25pF	GRM1882C1H9R4CA01#				
±0.5pF	GRM1882C1H9R4DA01#				
9.5pF	±0.05pF	GRM1882C1H9R5WA01#			
	±0.1pF	GRM1882C1H9R5BA01#			
	±0.25pF	GRM1882C1H9R5CA01#			
	±0.5pF	GRM1882C1H9R5DA01#			
9.6pF	±0.05pF	GRM1882C1H9R6WA01#			
	±0.1pF	GRM1882C1H9R6BA01#			
	±0.25pF	GRM1882C1H9R6CA01#			
	±0.5pF	GRM1882C1H9R6DA01#			
9.7pF	±0.05pF	GRM1882C1H9R7WA01#			
	±0.1pF	GRM1882C1H9R7BA01#			

品名 # 表示包装规格代码。

GRM 系列
GJM 系列
GMA 系列
GMD 系列
GQM 系列
GRJ 系列
GR3 系列
KRM 系列
KR3 系列
LLA 系列
LLL 系列
LLM 系列
LLR 系列
警告 / 注意事项

GRM 系列温度补偿型品名列表

(→ ■ 1.6×0.8mm)

T 最大值	额定 电压	温度特 性代号	静电容量	公差	品名	
0.9mm	50Vdc	CH	9.7pF	±0.25pF	GRM1882C1H9R7CA01#	
				±0.5pF	GRM1882C1H9R7DA01#	
			9.8pF	±0.05pF	GRM1882C1H9R8WA01#	
				±0.1pF	GRM1882C1H9R8BA01#	
				±0.25pF	GRM1882C1H9R8CA01#	
				±0.5pF	GRM1882C1H9R8DA01#	
			9.9pF	±0.05pF	GRM1882C1H9R9WA01#	
				±0.1pF	GRM1882C1H9R9BA01#	
				±0.25pF	GRM1882C1H9R9CA01#	
				±0.5pF	GRM1882C1H9R9DA01#	
			10pF	±5%	GRM1882C1H100JA01#	
			12pF	±5%	GRM1882C1H120JA01#	
			15pF	±5%	GRM1882C1H150JA01#	
			18pF	±5%	GRM1882C1H180JA01#	
			22pF	±5%	GRM1882C1H220JA01#	
			27pF	±5%	GRM1882C1H270JA01#	
			33pF	±5%	GRM1882C1H330JA01#	
			39pF	±5%	GRM1882C1H390JA01#	
			47pF	±5%	GRM1882C1H470JA01#	
			56pF	±5%	GRM1882C1H560JA01#	
			68pF	±5%	GRM1882C1H680JA01#	
			82pF	±5%	GRM1882C1H820JA01#	
			100pF	±5%	GRM1882C1H101JA01#	
			120pF	±5%	GRM1882C1H121JA01#	
			150pF	±5%	GRM1882C1H151JA01#	
			180pF	±5%	GRM1882C1H181JA01#	
			220pF	±5%	GRM1882C1H221JA01#	
			270pF	±5%	GRM1882C1H271JA01#	
			330pF	±5%	GRM1882C1H331JA01#	
			390pF	±5%	GRM1882C1H391JA01#	
			470pF	±5%	GRM1882C1H471JA01#	
			560pF	±5%	GRM1882C1H561JA01#	
			680pF	±5%	GRM1882C1H681JA01#	
			820pF	±5%	GRM1882C1H821JA01#	
			1000pF	±5%	GRM1882C1H102JA01#	
			1200pF	±5%	GRM1882C1H122JA01#	
			1500pF	±5%	GRM1882C1H152JA01#	
			1800pF	±5%	GRM1882C1H182JA01#	
			2200pF	±5%	GRM1882C1H222JA01#	
			2700pF	±5%	GRM1882C1H272JA01#	
			3300pF	±5%	GRM1882C1H332JA01#	
			3900pF	±5%	GRM1882C1H392JA01#	
			4700pF	±5%	GRM1882C1H472JA01#	
			5600pF	±5%	GRM1882C1H562JA01#	
			6800pF	±5%	GRM1882C1H682JA01#	
			8200pF	±5%	GRM1882C1H822JA01#	
			10000pF	±5%	GRM1882C1H103JA01#	
			SL	1200pF	±5%	GRM1881X1H122JA01#
				1500pF	±5%	GRM1881X1H152JA01#
				1800pF	±5%	GRM1881X1H182JA01#
				2200pF	±5%	GRM1881X1H222JA01#
2700pF	±5%	GRM1881X1H272JA01#				
3300pF	±5%	GRM1881X1H332JA01#				
3900pF	±5%	GRM1881X1H392JA01#				
4700pF	±5%	GRM1881X1H472JA01#				
5600pF	±5%	GRM1881X1H562JA01#				

T 最大值	额定 电压	温度特 性代号	静电容量	公差	品名		
0.9mm	50Vdc	SL	4700pF	±5%	GRM1881X1H472JA01#		
			5600pF	±5%	GRM1881X1H562JA01#		
			6800pF	±5%	GRM1881X1H682JA01#		
			8200pF	±5%	GRM1881X1H822JA01#		
			10000pF	±5%	GRM1881X1H103JA01#		
			U2J	1200pF	±5%	GRM1887U1H122JA01#	
				1500pF	±5%	GRM1887U1H152JA01#	
				1800pF	±5%	GRM1887U1H182JA01#	
				2200pF	±5%	GRM1887U1H222JA01#	
				2700pF	±5%	GRM1887U1H272JA01#	
				3300pF	±5%	GRM1887U1H332JA01#	
				3900pF	±5%	GRM1887U1H392JA01#	
				4700pF	±5%	GRM1887U1H472JA01#	
				5600pF	±5%	GRM1887U1H562JA01#	
				6800pF	±5%	GRM1887U1H682JA01#	
		8200pF		±5%	GRM1887U1H822JA01#		
		10000pF		±5%	GRM1887U1H103JA01#		
		UJ		1000pF	±5%	GRM1883U1H102JA01#	
				1200pF	±5%	GRM1883U1H122JA01#	
				1500pF	±5%	GRM1883U1H152JA01#	
			1800pF	±5%	GRM1883U1H182JA01#		
			2200pF	±5%	GRM1883U1H222JA01#		
			2700pF	±5%	GRM1883U1H272JA01#		
			3300pF	±5%	GRM1883U1H332JA01#		
			3900pF	±5%	GRM1883U1H392JA01#		
			4700pF	±5%	GRM1883U1H472JA01#		
			5600pF	±5%	GRM1883U1H562JA01#		
			6800pF	±5%	GRM1883U1H682JA01#		
			8200pF	±5%	GRM1883U1H822JA01#		
			10000pF	±5%	GRM1883U1H103JA01#		
			10Vdc	SL	12000pF	±5%	GRM1881X1A123JA01#
					15000pF	±5%	GRM1881X1A153JA01#
		18000pF			±5%	GRM1881X1A183JA01#	
		22000pF			±5%	GRM1881X1A223JA01#	
		27000pF			±5%	GRM1881X1A273JA01#	
		U2J		12000pF	±5%	GRM1887U1A123JA01#	
				15000pF	±5%	GRM1887U1A153JA01#	
				18000pF	±5%	GRM1887U1A183JA01#	
				22000pF	±5%	GRM1887U1A223JA01#	
				27000pF	±5%	GRM1887U1A273JA01#	
		UJ		12000pF	±5%	GRM1883U1A123JA01#	
				15000pF	±5%	GRM1883U1A153JA01#	
				18000pF	±5%	GRM1883U1A183JA01#	
				22000pF	±5%	GRM1883U1A223JA01#	
				27000pF	±5%	GRM1883U1A273JA01#	

■ 2.0×1.25mm

T 最大值	额定 电压	温度特 性代号	静电容量	公差	品名
0.7mm	100Vdc	C0G	100pF	±5%	GRM2165C2A101JA01#
			120pF	±5%	GRM2165C2A121JA01#
			150pF	±5%	GRM2165C2A151JA01#
			180pF	±5%	GRM2165C2A181JA01#
			220pF	±5%	GRM2165C2A221JA01#
			270pF	±5%	GRM2165C2A271JA01#
			330pF	±5%	GRM2165C2A331JA01#

品名 # 表示包装规格代码。

GRM 系列
GJM 系列
GMA 系列
GMD 系列
GQM 系列
GRJ 系列
GR3 系列
KRM 系列
KR3 系列
LLA 系列
LLL 系列
LLM 系列
LLR 系列
警告/注意事项

GRM 系列温度补偿型品名列表

(→ ■ 2.0×1.25mm)

T 最大值	额定 电压	温度特 性代号	静电容量	公差	品名	
0.7mm	100Vdc	C0G	390pF	±5%	GRM2165C2A391JA01#	
			470pF	±5%	GRM2165C2A471JA01#	
			560pF	±5%	GRM2165C2A561JA01#	
			680pF	±5%	GRM2165C2A681JA01#	
			820pF	±5%	GRM2165C2A821JA01#	
			1000pF	±5%	GRM2165C2A102JA01#	
			1200pF	±5%	GRM2165C2A122JA01#	
			1500pF	±5%	GRM2165C2A152JA01#	
			1800pF	±5%	GRM2165C2A182JA01#	
			2200pF	±5%	GRM2165C2A222JA01#	
			2700pF	±5%	GRM2165C2A272JA01#	
			3300pF	±5%	GRM2165C2A332JA01#	
			CH	100pF	±5%	GRM2162C2A101JA01#
				120pF	±5%	GRM2162C2A121JA01#
				150pF	±5%	GRM2162C2A151JA01#
		180pF		±5%	GRM2162C2A181JA01#	
		220pF		±5%	GRM2162C2A221JA01#	
		270pF		±5%	GRM2162C2A271JA01#	
		330pF		±5%	GRM2162C2A331JA01#	
		390pF		±5%	GRM2162C2A391JA01#	
		470pF		±5%	GRM2162C2A471JA01#	
		560pF		±5%	GRM2162C2A561JA01#	
		680pF		±5%	GRM2162C2A681JA01#	
		820pF		±5%	GRM2162C2A821JA01#	
		1000pF		±5%	GRM2162C2A102JA01#	
		1200pF		±5%	GRM2162C2A122JA01#	
		1500pF		±5%	GRM2162C2A152JA01#	
		1800pF		±5%	GRM2162C2A182JA01#	
		2200pF		±5%	GRM2162C2A222JA01#	
		2700pF		±5%	GRM2162C2A272JA01#	
		3300pF	±5%	GRM2162C2A332JA01#		
		50Vdc	C0G	1200pF	±5%	GRM2165C1H122JA01#
				1500pF	±5%	GRM2165C1H152JA01#
	1800pF			±5%	GRM2165C1H182JA01#	
	2200pF			±5%	GRM2165C1H222JA01#	
	2700pF			±5%	GRM2165C1H272JA01#	
	3300pF			±5%	GRM2165C1H332JA01#	
	CH		1200pF	±5%	GRM2162C1H122JA01#	
			1500pF	±5%	GRM2162C1H152JA01#	
			1800pF	±5%	GRM2162C1H182JA01#	
			2200pF	±5%	GRM2162C1H222JA01#	
			2700pF	±5%	GRM2162C1H272JA01#	
			3300pF	±5%	GRM2162C1H332JA01#	
	SL	1200pF	±5%	GRM2161X1H123JA01#		
		1500pF	±5%	GRM2161X1H153JA01#		
1800pF		±5%	GRM2161X1H183JA01#			
U2J		1200pF	±5%	GRM2167U1H123JA01#		
		1500pF	±5%	GRM2167U1H153JA01#		
		1800pF	±5%	GRM2167U1H183JA01#		
UJ	10000pF	±5%	GRM2163U1H103JA01#			

T 最大值	额定 电压	温度特 性代号	静电容量	公差	品名
0.7mm	50Vdc	UJ	12000pF	±5%	GRM2163U1H123JA01#
			15000pF	±5%	GRM2163U1H153JA01#
			18000pF	±5%	GRM2163U1H183JA01#
0.95mm	50Vdc	C0G	5600pF	±5%	GRM2195C1H562JA01#
			6800pF	±5%	GRM2195C1H682JA01#
			8200pF	±5%	GRM2195C1H822JA01#
			10000pF	±5%	GRM2195C1H103JA01#
			12000pF	±5%	GRM2195C1H123JA01#
			15000pF	±5%	GRM2195C1H153JA01#
		CH	5600pF	±5%	GRM2192C1H562JA01#
			6800pF	±5%	GRM2192C1H682JA01#
			8200pF	±5%	GRM2192C1H822JA01#
			10000pF	±5%	GRM2192C1H103JA01#
			12000pF	±5%	GRM2192C1H123JA01#
			15000pF	±5%	GRM2192C1H153JA01#
	10Vdc	SL	22000pF	±5%	GRM2191X1H223JA01#
			27000pF	±5%	GRM2191X1H273JA01#
		U2J	22000pF	±5%	GRM2197U1H223JA01#
			27000pF	±5%	GRM2197U1H273JA01#
		UJ	22000pF	±5%	GRM2193U1H223JA01#
			27000pF	±5%	GRM2193U1H273JA01#
1.0mm	250Vdc	C0G	10pF	±5%	GRM21A5C2E100JW01#
			12pF	±5%	GRM21A5C2E120JW01#
			15pF	±5%	GRM21A5C2E150JW01#
			18pF	±5%	GRM21A5C2E180JW01#
			22pF	±5%	GRM21A5C2E220JW01#
			27pF	±5%	GRM21A5C2E270JW01#
			33pF	±5%	GRM21A5C2E330JW01#
			39pF	±5%	GRM21A5C2E390JW01#
			47pF	±5%	GRM21A5C2E470JW01#
			56pF	±5%	GRM21A5C2E560JW01#
			68pF	±5%	GRM21A5C2E680JW01#
			82pF	±5%	GRM21A5C2E820JW01#
	U2J	100pF	±5%	GRM21A7U2E101JW31#	
		120pF	±5%	GRM21A7U2E121JW31#	
		150pF	±5%	GRM21A7U2E151JW31#	
		180pF	±5%	GRM21A7U2E181JW31#	
		220pF	±5%	GRM21A7U2E221JW31#	
		270pF	±5%	GRM21A7U2E271JW31#	
		330pF	±5%	GRM21A7U2E331JW31#	
		390pF	±5%	GRM21A7U2E391JW31#	
		470pF	±5%	GRM21A7U2E471JW31#	
		560pF	±5%	GRM21A7U2E561JW31#	
		680pF	±5%	GRM21A7U2E681JW31#	

品名 # 表示包装规格代码。

- GRM 系列
- GJM 系列
- GMA 系列
- GMD 系列
- GQM 系列
- GRJ 系列
- GR3 系列
- KRM 系列
- KR3 系列
- L1A 系列
- L1L 系列
- L1M 系列
- L1R 系列
- 警告 / 注意事項

GRM 系列温度补偿型品名列表

(→ ■ 2.0×1.25mm)

T 最大值	额定 电压	温度特 性代号	静电容量	公差	品名	
1.0mm	250Vdc	U2J	820pF	±5%	GRM21A7U2E821JW31#	
			1000pF	±5%	GRM21A7U2E102JW31#	
			1200pF	±5%	GRM21A7U2E122JW31#	
			1500pF	±5%	GRM21A7U2E152JW31#	
			1800pF	±5%	GRM21A7U2E182JW31#	
			2200pF	±5%	GRM21A7U2E222JW31#	
		200Vdc	C0G	10pF	±5%	GRM21A5C2D100JW01#
				12pF	±5%	GRM21A5C2D120JW01#
				15pF	±5%	GRM21A5C2D150JW01#
				18pF	±5%	GRM21A5C2D180JW01#
				22pF	±5%	GRM21A5C2D220JW01#
				27pF	±5%	GRM21A5C2D270JW01#
				33pF	±5%	GRM21A5C2D330JW01#
				39pF	±5%	GRM21A5C2D390JW01#
				47pF	±5%	GRM21A5C2D470JW01#
	56pF			±5%	GRM21A5C2D560JW01#	
	68pF			±5%	GRM21A5C2D680JW01#	
	82pF			±5%	GRM21A5C2D820JW01#	
	100pF			±5%	GRM21A5C2D101JW01#	
	120pF			±5%	GRM21A5C2D121JW01#	
	150pF			±5%	GRM21A5C2D151JW01#	
	180pF		±5%	GRM21A5C2D181JW01#		
	220pF		±5%	GRM21A5C2D221JW01#		
	270pF		±5%	GRM21A5C2D271JW01#		
	330pF		±5%	GRM21A5C2D331JW01#		
	U2J		100pF	±5%	GRM21A7U2D101JW31#	
			120pF	±5%	GRM21A7U2D121JW31#	
			150pF	±5%	GRM21A7U2D151JW31#	
			180pF	±5%	GRM21A7U2D181JW31#	
			220pF	±5%	GRM21A7U2D221JW31#	
			270pF	±5%	GRM21A7U2D271JW31#	
			330pF	±5%	GRM21A7U2D331JW31#	
			390pF	±5%	GRM21A7U2D391JW31#	
			470pF	±5%	GRM21A7U2D471JW31#	
			560pF	±5%	GRM21A7U2D561JW31#	
			680pF	±5%	GRM21A7U2D681JW31#	
		820pF	±5%	GRM21A7U2D821JW31#		
		1000pF	±5%	GRM21A7U2D102JW31#		
		1200pF	±5%	GRM21A7U2D122JW31#		
		1500pF	±5%	GRM21A7U2D152JW31#		
	1800pF	±5%	GRM21A7U2D182JW31#			
	2200pF	±5%	GRM21A7U2D222JW31#			
	50Vdc	SL	33000pF	±5%	GRM21A1X1H333JA39#	
			U2J	33000pF	±5%	GRM21A7U1H333JA39#
			UJ	33000pF	±5%	GRM21A3U1H333JA39#
1.35mm		50Vdc	C0G	18000pF	±5%	GRM21B5C1H183JA01#
				22000pF	±5%	GRM21B5C1H223JA01#
			CH	18000pF	±5%	GRM21B2C1H183JA01#
	22000pF	±5%		GRM21B2C1H223JA01#		
	SL	39000pF	±5%	GRM21B1X1H393JA01#		
		47000pF	±5%	GRM21B1X1H473JA01#		
U2J	39000pF	±5%	GRM21B7U1H393JA01#			
	47000pF	±5%	GRM21B7U1H473JA01#			
UJ	39000pF	±5%	GRM21B3U1H393JA01#			

T 最大值	额定 电压	温度特 性代号	静电容量	公差	品名	
1.35mm	50Vdc	UJ	47000pF	±5%	GRM21B3U1H473JA01#	
			SL	68000pF	±5%	GRM21B1X1A683JA01#
			82000pF	±5%	GRM21B1X1A823JA01#	
		U2J	0.10μF	±5%	GRM21B1X1A104JA01#	
			68000pF	±5%	GRM21B7U1A683JA01#	
			82000pF	±5%	GRM21B7U1A823JA01#	
	250Vdc	U2J	0.10μF	±5%	GRM21B7U1A104JA01#	
			68000pF	±5%	GRM21B3U1A683JA01#	
			82000pF	±5%	GRM21B3U1A823JA01#	
		UJ	0.10μF	±5%	GRM21B3U1A104JA01#	
			68000pF	±5%	GRM21B3U1A683JA01#	
			82000pF	±5%	GRM21B3U1A823JA01#	
1.45mm	250Vdc	U2J	2700pF	±5%	GRM21B7U2E272JW32#	
			3300pF	±5%	GRM21B7U2E332JW32#	
			3900pF	±5%	GRM21B7U2E392JW32#	
		U2J	4700pF	±5%	GRM21B7U2E472JW32#	
			5600pF	±5%	GRM21B7U2E562JW32#	
			2700pF	±5%	GRM21B7U2D272JW32#	
	200Vdc	U2J	3300pF	±5%	GRM21B7U2D332JW32#	
			3900pF	±5%	GRM21B7U2D392JW32#	
			4700pF	±5%	GRM21B7U2D472JW32#	
		U2J	5600pF	±5%	GRM21B7U2D562JW32#	
			2700pF	±5%	GRM21B7U2D272JW32#	
			3300pF	±5%	GRM21B7U2D332JW32#	
3900pF	±5%	GRM21B7U2D392JW32#				
4700pF	±5%	GRM21B7U2D472JW32#				
5600pF	±5%	GRM21B7U2D562JW32#				

■ 3.2×1.6mm

T 最大值	额定 电压	温度特 性代号	静电容量	公差	品名
0.95mm	100Vdc	C0G	1800pF	±5%	GRM3195C2A182JA01#
			2200pF	±5%	GRM3195C2A222JA01#
			2700pF	±5%	GRM3195C2A272JA01#
			3300pF	±5%	GRM3195C2A332JA01#
			3900pF	±5%	GRM3195C2A392JA01#
			4700pF	±5%	GRM3195C2A472JA01#
			5600pF	±5%	GRM3195C2A562JA01#
			6800pF	±5%	GRM3195C2A682JA01#
			8200pF	±5%	GRM3195C2A822JA01#
			10000pF	±5%	GRM3195C2A103JA01#
			12000pF	±5%	GRM3195C2A123JA01#
			15000pF	±5%	GRM3195C2A153JA01#
	18000pF	±5%	GRM3195C2A183JA01#		
	22000pF	±5%	GRM3195C2A223JA01#		
	CH	1800pF	±5%	GRM3192C2A182JA01#	
		2200pF	±5%	GRM3192C2A222JA01#	
		2700pF	±5%	GRM3192C2A272JA01#	
		3300pF	±5%	GRM3192C2A332JA01#	
		3900pF	±5%	GRM3192C2A392JA01#	
		4700pF	±5%	GRM3192C2A472JA01#	
		5600pF	±5%	GRM3192C2A562JA01#	
		6800pF	±5%	GRM3192C2A682JA01#	
		8200pF	±5%	GRM3192C2A822JA01#	
		10000pF	±5%	GRM3192C2A103JA01#	
12000pF		±5%	GRM3192C2A123JA01#		
15000pF		±5%	GRM3192C2A153JA01#		
18000pF	±5%	GRM3192C2A183JA01#			
22000pF	±5%	GRM3192C2A223JA01#			
50Vdc	C0G	12000pF	±5%	GRM3195C1H123JA01#	

品名 # 表示包装规格代码。

GRM 系列
GJM 系列
GMA 系列
GMD 系列
GQM 系列
GRJ 系列
GR3 系列
KRM 系列
KR3 系列
LLA 系列
LLL 系列
LLM 系列
LLR 系列
警告/注意事项

GRM 系列温度补偿型品名列表

(→ ■ 3.2×1.6mm)

T 最大值	额定 电压	温度特 性代号	静电容量	公差	品名		
0.95mm	50Vdc	COG	1500pF	±5%	GRM3195C1H153JA01#		
			1800pF	±5%	GRM3195C1H183JA01#		
			2200pF	±5%	GRM3195C1H223JA01#		
			2700pF	±5%	GRM3195C1H273JA01#		
			3300pF	±5%	GRM3195C1H333JA01#		
			3900pF	±5%	GRM3195C1H393JA01#		
			CH	1200pF	±5%	GRM3192C1H123JA01#	
				1500pF	±5%	GRM3192C1H153JA01#	
				1800pF	±5%	GRM3192C1H183JA01#	
				2200pF	±5%	GRM3192C1H223JA01#	
		2700pF		±5%	GRM3192C1H273JA01#		
		3300pF		±5%	GRM3192C1H333JA01#		
		SL	5600pF	±5%	GRM3191X1H563JA01#		
			U2J	5600pF	±5%	GRM3197U1H563JA01#	
				UJ	5600pF	±5%	GRM3193U1H563JA01#
			1.0mm	2000Vdc	U2J	10pF	±5%
		12pF				±5%	GRM31A7U3D120JW31#
		15pF				±5%	GRM31A7U3D150JW31#
		18pF				±5%	GRM31A7U3D180JW31#
		22pF				±5%	GRM31A7U3D220JW31#
27pF	±5%	GRM31A7U3D270JW31#					
33pF	±5%	GRM31A7U3D330JW31#					
39pF	±5%	GRM31A7U3D390JW31#					
47pF	±5%	GRM31A7U3D470JW31#					
56pF	±5%	GRM31A7U3D560JW31#					
68pF	±5%	GRM31A7U3D680JW31#					
1000Vdc	COG	10pF				±5%	GRM31A5C3A100JW01#
		12pF				±5%	GRM31A5C3A120JW01#
		15pF				±5%	GRM31A5C3A150JW01#
		18pF	±5%	GRM31A5C3A180JW01#			
		22pF	±5%	GRM31A5C3A220JW01#			
		27pF	±5%	GRM31A5C3A270JW01#			
		33pF	±5%	GRM31A5C3A330JW01#			
		39pF	±5%	GRM31A5C3A390JW01#			
		47pF	±5%	GRM31A5C3A470JW01#			
		56pF	±5%	GRM31A5C3A560JW01#			
		68pF	±5%	GRM31A5C3A680JW01#			
		82pF	±5%	GRM31A5C3A820JW01#			
		100pF	±5%	GRM31A5C3A101JW01#			
		120pF	±5%	GRM31A5C3A121JW01#			
150pF	±5%	GRM31A5C3A151JW01#					
180pF	±5%	GRM31A5C3A181JW01#					
220pF	±5%	GRM31A5C3A221JW01#					
1.0mm	2000Vdc	U2J	10pF	±5%	GRM31A7U3A100JW31#		
			12pF	±5%	GRM31A7U3A120JW31#		
			15pF	±5%	GRM31A7U3A150JW31#		
			18pF	±5%	GRM31A7U3A180JW31#		
			22pF	±5%	GRM31A7U3A220JW31#		
			27pF	±5%	GRM31A7U3A270JW31#		
			33pF	±5%	GRM31A7U3A330JW31#		
			39pF	±5%	GRM31A7U3A390JW31#		
			47pF	±5%	GRM31A7U3A470JW31#		
			56pF	±5%	GRM31A7U3A560JW31#		
			68pF	±5%	GRM31A7U3A680JW31#		
			82pF	±5%	GRM31A7U3A820JW31#		
			100pF	±5%	GRM31A7U3A101JW31#		
			120pF	±5%	GRM31A7U3A121JW31#		

T 最大值	额定 电压	温度特 性代号	静电容量	公差	品名
1.0mm	1000Vdc	U2J	68pF	±5%	GRM31A7U3A680JW31#
			82pF	±5%	GRM31A7U3A820JW31#
			100pF	±5%	GRM31A7U3A101JW31#
			120pF	±5%	GRM31A7U3A121JW31#
			150pF	±5%	GRM31A7U3A151JW31#
			180pF	±5%	GRM31A7U3A181JW31#
			220pF	±5%	GRM31A7U3A221JW31#
			270pF	±5%	GRM31A7U3A271JW31#
			330pF	±5%	GRM31A7U3A331JW31#
			390pF	±5%	GRM31A7U3A391JW31#
	630Vdc	COG	10pF	±5%	GRM31A5C2J100JW01#
			12pF	±5%	GRM31A5C2J120JW01#
			15pF	±5%	GRM31A5C2J150JW01#
			18pF	±5%	GRM31A5C2J180JW01#
			22pF	±5%	GRM31A5C2J220JW01#
			27pF	±5%	GRM31A5C2J270JW01#
			33pF	±5%	GRM31A5C2J330JW01#
			39pF	±5%	GRM31A5C2J390JW01#
			47pF	±5%	GRM31A5C2J470JW01#
			56pF	±5%	GRM31A5C2J560JW01#
630Vdc	U2J	10pF	±5%	GRM31A7U2J100JW31#	
		12pF	±5%	GRM31A7U2J120JW31#	
		15pF	±5%	GRM31A7U2J150JW31#	
		18pF	±5%	GRM31A7U2J180JW31#	
		22pF	±5%	GRM31A7U2J220JW31#	
		27pF	±5%	GRM31A7U2J270JW31#	
		33pF	±5%	GRM31A7U2J330JW31#	
		39pF	±5%	GRM31A7U2J390JW31#	
		47pF	±5%	GRM31A7U2J470JW31#	
		56pF	±5%	GRM31A7U2J560JW31#	
630Vdc	U2J	68pF	±5%	GRM31A7U2J680JW31#	
		82pF	±5%	GRM31A7U2J820JW31#	
		100pF	±5%	GRM31A7U2J101JW31#	
		120pF	±5%	GRM31A7U2J121JW31#	
		150pF	±5%	GRM31A7U2J151JW31#	
		180pF	±5%	GRM31A7U2J181JW31#	
		220pF	±5%	GRM31A7U2J221JW31#	
		270pF	±5%	GRM31A7U2J271JW31#	
		330pF	±5%	GRM31A7U2J331JW31#	
		390pF	±5%	GRM31A7U2J391JW31#	
630Vdc	U2J	470pF	±5%	GRM31A7U2J471JW31#	
		560pF	±5%	GRM31A7U2J561JW31#	
		680pF	±5%	GRM31A7U2J681JW31#	

品名 # 表示包装规格代码。

GRM 系列
GJM 系列
GMA 系列
GMD 系列
GQM 系列
GRJ 系列
GR3 系列
KRM 系列
KR3 系列
LLA 系列
LLL 系列
LLM 系列
LLR 系列
警告 / 注意事项

GRM 系列温度补偿型品名列表

(→ ■ 3.2×1.6mm)

T 最大值	额定 电压	温度特 性代号	静电容量	公差	品名		
1.0mm	630Vdc	U2J	820pF	±5%	GRM31A7U2J821JW31#		
			1000pF	±5%	GRM31A7U2J102JW31#		
			1200pF	±5%	GRM31A7U2J122JW31#		
			1500pF	±5%	GRM31A7U2J152JW31#		
			1800pF	±5%	GRM31A7U2J182JW31#		
			2200pF	±5%	GRM31A7U2J222JW31#		
			500Vdc	C0G	10pF	±5%	GRM31A5C2H100JW01#
					12pF	±5%	GRM31A5C2H120JW01#
					15pF	±5%	GRM31A5C2H150JW01#
					18pF	±5%	GRM31A5C2H180JW01#
					22pF	±5%	GRM31A5C2H220JW01#
					27pF	±5%	GRM31A5C2H270JW01#
	33pF	±5%			GRM31A5C2H330JW01#		
	39pF	±5%			GRM31A5C2H390JW01#		
	47pF	±5%			GRM31A5C2H470JW01#		
	56pF	±5%			GRM31A5C2H560JW01#		
	68pF	±5%			GRM31A5C2H680JW01#		
	82pF	±5%			GRM31A5C2H820JW01#		
	100pF	±5%			GRM31A5C2H101JW01#		
	120pF	±5%			GRM31A5C2H121JW01#		
	150pF	±5%			GRM31A5C2H151JW01#		
	180pF	±5%			GRM31A5C2H181JW01#		
	220pF	±5%			GRM31A5C2H221JW01#		
	270pF	±5%			GRM31A5C2H271JW01#		
	330pF	±5%			GRM31A5C2H331JW01#		
	390pF	±5%			GRM31A5C2H391JW01#		
	470pF	±5%			GRM31A5C2H471JW01#		
	560pF	±5%			GRM31A5C2H561JW01#		
	U2J	U2J			10pF	±5%	GRM31A7U2H100JW31#
					12pF	±5%	GRM31A7U2H120JW31#
					15pF	±5%	GRM31A7U2H150JW31#
					18pF	±5%	GRM31A7U2H180JW31#
					22pF	±5%	GRM31A7U2H220JW31#
					27pF	±5%	GRM31A7U2H270JW31#
					33pF	±5%	GRM31A7U2H330JW31#
					39pF	±5%	GRM31A7U2H390JW31#
					47pF	±5%	GRM31A7U2H470JW31#
					56pF	±5%	GRM31A7U2H560JW31#
					68pF	±5%	GRM31A7U2H680JW31#
					82pF	±5%	GRM31A7U2H820JW31#
					100pF	±5%	GRM31A7U2H101JW31#
					120pF	±5%	GRM31A7U2H121JW31#
			150pF	±5%	GRM31A7U2H151JW31#		
			180pF	±5%	GRM31A7U2H181JW31#		
			220pF	±5%	GRM31A7U2H221JW31#		
			270pF	±5%	GRM31A7U2H271JW31#		
			330pF	±5%	GRM31A7U2H331JW31#		
			390pF	±5%	GRM31A7U2H391JW31#		
			470pF	±5%	GRM31A7U2H471JW31#		
			560pF	±5%	GRM31A7U2H561JW31#		
			680pF	±5%	GRM31A7U2H681JW31#		
			820pF	±5%	GRM31A7U2H821JW31#		
1000pF	±5%	GRM31A7U2H102JW31#					
1200pF	±5%	GRM31A7U2H122JW31#					

T 最大值	额定 电压	温度特 性代号	静电容量	公差	品名				
1.0mm	500Vdc	U2J	1500pF	±5%	GRM31A7U2H152JW31#				
			1800pF	±5%	GRM31A7U2H182JW31#				
			2200pF	±5%	GRM31A7U2H222JW31#				
			250Vdc	U2J	2700pF	±5%	GRM31A7U2E272JW31#		
					3300pF	±5%	GRM31A7U2E332JW31#		
					3900pF	±5%	GRM31A7U2E392JW31#		
	4700pF	±5%			GRM31A7U2E472JW31#				
	5600pF	±5%			GRM31A7U2E562JW31#				
	200Vdc	U2J			2700pF	±5%	GRM31A7U2D272JW31#		
			3300pF	±5%	GRM31A7U2D332JW31#				
			3900pF	±5%	GRM31A7U2D392JW31#				
			4700pF	±5%	GRM31A7U2D472JW31#				
			5600pF	±5%	GRM31A7U2D562JW31#				
			1000Vdc	U2J	390pF	±5%	GRM31B7U3A391JW31#		
					470pF	±5%	GRM31B7U3A471JW31#		
					560pF	±5%	GRM31B7U3A561JW31#		
					680pF	±5%	GRM31B7U3A681JW31#		
					630Vdc	C0G	680pF	±5%	GRM31B5C2J681JW01#
							820pF	±5%	GRM31B5C2J821JW01#
			1000pF	±5%			GRM31B5C2J102JW01#		
	U2J	2700pF	±5%	GRM31B7U2J272JW31#					
		3300pF	±5%	GRM31B7U2J332JW31#					
		500Vdc	C0G	680pF		±5%	GRM31B5C2H681JW01#		
	820pF			±5%	GRM31B5C2H821JW01#				
1000pF	±5%			GRM31B5C2H102JW01#					
U2J	2700pF		±5%	GRM31B7U2H272JW31#					
	3300pF		±5%	GRM31B7U2H332JW31#					
	250Vdc		U2J	6800pF	±5%	GRM31B7U2E682JW31#			
8200pF		±5%		GRM31B7U2E822JW31#					
10000pF		±5%		GRM31B7U2E103JW31#					
12000pF		±5%		GRM31B7U2E123JW31#					
200Vdc		U2J		6800pF	±5%	GRM31B7U2D682JW31#			
				8200pF	±5%	GRM31B7U2D822JW31#			
	10000pF		±5%	GRM31B7U2D103JW31#					
	50Vdc		C0G	47000pF	±5%	GRM31M5C1H473JA01#			
				56000pF	±5%	GRM31M5C1H563JA01#			
				CH	47000pF	±5%	GRM31M2C1H473JA01#		
56000pF		±5%	GRM31M2C1H563JA01#						
SL		68000pF	±5%		GRM31M1X1H683JA01#				
		82000pF	±5%	GRM31M1X1H823JA01#					
	0.10μF	±5%	GRM31M1X1H104JA01#						
U2J	U2J	68000pF	±5%	GRM31M7U1H683JA01#					
		82000pF	±5%	GRM31M7U1H823JA01#					
		0.10μF	±5%	GRM31M7U1H104JA01#					
		UJ	68000pF	±5%	GRM31M3U1H683JA01#				
			82000pF	±5%	GRM31M3U1H823JA01#				
			0.10μF	±5%	GRM31M3U1H104JA01#				
1.8mm	1000Vdc	U2J	820pF	±5%	GRM31C7U3A821JW32#				
			1000pF	±5%	GRM31C7U3A102JW32#				
			4700pF	±5%	GRM31C7U2J472JW32#				
			4700pF	±5%	GRM31C7U2H472JW32#				
	630Vdc	U2J	3900pF	±5%	GRM31C7U2J392JW32#				
			4700pF	±5%	GRM31C7U2J472JW32#				
			4700pF	±5%	GRM31C7U2H392JW32#				
			4700pF	±5%	GRM31C7U2H472JW32#				
	500Vdc	U2J	3900pF	±5%	GRM31C7U2H392JW32#				
			4700pF	±5%	GRM31C7U2H472JW32#				
			250Vdc	U2J	15000pF	±5%	GRM31C7U2E153JW32#		

品名 # 表示包装规格代码。

GRM 系列
GJM 系列
GMA 系列
GMD 系列
GQM 系列
GRJ 系列
GR3 系列
KRM 系列
KR3 系列
LLA 系列
LLL 系列
LLM 系列
LLR 系列
警告/注意事项

GRM 系列温度补偿型品名列表

(→ ■ 3.2×1.6mm)

T 最大值	额定 电压	温度特 性代号	静电容量	公差	品名	
1.8mm	250Vdc	U2J	1800pF	±5%	GRM31C7U2E183JW32#	
			2200pF	±5%	GRM31C7U2E223JW32#	
		COG	6800pF	±5%	GRM31C5C1H683JA01#	
			8200pF	±5%	GRM31C5C1H823JA01#	
			0.10μF	±5%	GRM31C5C1H104JA01#	
			CH	6800pF	±5%	GRM31C2C1H683JA01#
	50Vdc	CH	8200pF	±5%	GRM31C2C1H823JA01#	
			0.10μF	±5%	GRM31C2C1H104JA01#	
		COG	0.12μF	±5%	GRM31C5C1E124JA01#	
			CH	0.12μF	±5%	GRM31C2C1E124JA01#
		16Vdc	COG	0.12μF	±5%	GRM31C5C1C124JA01#
				CH	0.12μF	±5%

T 最大值	额定 电压	温度特 性代号	静电容量	公差	品名	
1.0mm	3150Vdc	COG	12pF	±5%	GRM42A5C3F120JW01#	
			15pF	±5%	GRM42A5C3F150JW01#	
			18pF	±5%	GRM42A5C3F180JW01#	
			22pF	±5%	GRM42A5C3F220JW01#	
			27pF	±5%	GRM42A5C3F270JW01#	
			33pF	±5%	GRM42A5C3F330JW01#	
			39pF	±5%	GRM42A5C3F390JW01#	
			47pF	±5%	GRM42A5C3F470JW01#	
			U2J	10pF	±5%	GRM42A7U3F100JW31#
				12pF	±5%	GRM42A7U3F120JW31#
				15pF	±5%	GRM42A7U3F150JW31#
				18pF	±5%	GRM42A7U3F180JW31#
				22pF	±5%	GRM42A7U3F220JW31#
				27pF	±5%	GRM42A7U3F270JW31#
			33pF	±5%	GRM42A7U3F330JW31#	
			39pF	±5%	GRM42A7U3F390JW31#	
			47pF	±5%	GRM42A7U3F470JW31#	
			56pF	±5%	GRM42A7U3F560JW31#	
		68pF	±5%	GRM42A7U3F680JW31#		
		82pF	±5%	GRM42A7U3F820JW31#		
		100pF	±5%	GRM42A7U3F101JW31#		

■ 3.2×2.5mm

T 最大值	额定 电压	温度特 性代号	静电容量	公差	品名	
1.0mm	2000Vdc	U2J	82pF	±5%	GRM32A7U3D820JW31#	
			100pF	±5%	GRM32A7U3D101JW31#	
			120pF	±5%	GRM32A7U3D121JW31#	
			150pF	±5%	GRM32A7U3D151JW31#	
		630Vdc	U2J	1200pF	±5%	GRM32A7U2J122JW31#
				1500pF	±5%	GRM32A7U2J152JW31#
				1800pF	±5%	GRM32A7U2J182JW31#
				2200pF	±5%	GRM32A7U2J222JW31#
		500Vdc	U2J	1200pF	±5%	GRM32A7U2H122JW31#
				1500pF	±5%	GRM32A7U2H152JW31#
				1800pF	±5%	GRM32A7U2H182JW31#
				2200pF	±5%	GRM32A7U2H222JW31#
	1.25mm	2000Vdc	U2J	180pF	±5%	GRM32B7U3D181JW31#
				220pF	±5%	GRM32B7U3D221JW31#
		1000Vdc	U2J	1200pF	±5%	GRM32B7U3A122JW31#
				630Vdc	U2J	5600pF
		500Vdc	U2J	5600pF	±5%	GRM32B7U2H562JW31#
				1.5mm	1000Vdc	U2J
	U2J	6800pF	±5%	GRM32Q7U2J682JW31#		
	U2J	6800pF	±5%	GRM32Q7U2H682JW31#		
	U2J	27000pF	±5%	GRM32Q7U2E273JW31#		
	2.0mm	1000Vdc	U2J	180pF	±5%	GRM32D7U3A182JW31#
				220pF	±5%	GRM32D7U3A222JW31#
		630Vdc	U2J	8200pF	±5%	GRM32D7U2J822JW31#
10000pF				±5%	GRM32D7U2J103JW31#	
500Vdc		U2J	8200pF	±5%	GRM32D7U2H822JW31#	
			10000pF	±5%	GRM32D7U2H103JW31#	
250Vdc		U2J	33000pF	±5%	GRM32D7U2E333JW31#	
			39000pF	±5%	GRM32D7U2E393JW31#	
			47000pF	±5%	GRM32D7U2E473JW31#	

■ 4.5×2.0mm

T 最大值	额定 电压	温度特 性代号	静电容量	公差	品名
1.0mm	3150Vdc	COG	5.0pF	±0.5pF	GRM42A5C3F050DW01#
			10pF	±5%	GRM42A5C3F100JW01#

■ 4.5×3.2mm

T 最大值	额定 电压	温度特 性代号	静电容量	公差	品名	
1.5mm	1000Vdc	U2J	2700pF	±5%	GRM43Q7U3A272JW31#	
			3300pF	±5%	GRM43Q7U3A332JW31#	
	630Vdc	U2J	12000pF	±5%	GRM43Q7U2J123JW31#	
			500Vdc	U2J	12000pF	±5%
	2.0mm	1000Vdc	U2J	3900pF	±5%	GRM43D7U3A392JW31#
				4700pF	±5%	GRM43D7U3A472JW31#
630Vdc		U2J	15000pF	±5%	GRM43D7U2J153JW31#	
			18000pF	±5%	GRM43D7U2J183JW31#	
500Vdc		U2J	22000pF	±5%	GRM43D7U2J223JW31#	
			15000pF	±5%	GRM43D7U2H153JW31#	
18000pF	±5%	GRM43D7U2H183JW31#				
22000pF	±5%	GRM43D7U2H223JW31#				

■ 5.7×5.0mm

T 最大值	额定 电压	温度特 性代号	静电容量	公差	品名	
1.5mm	1000Vdc	U2J	5600pF	±5%	GRM55Q7U3A562JW31#	
			6800pF	±5%	GRM55Q7U3A682JW31#	
	630Vdc	U2J	27000pF	±5%	GRM55Q7U2J273JW31#	
			500Vdc	U2J	27000pF	±5%
	2.0mm	1000Vdc	U2J	8200pF	±5%	GRM55D7U3A822JW31#
				10000pF	±5%	GRM55D7U3A103JW31#
630Vdc		U2J	33000pF	±5%	GRM55D7U2J333JW31#	
			39000pF	±5%	GRM55D7U2J393JW31#	
500Vdc		U2J	47000pF	±5%	GRM55D7U2J473JW31#	
			33000pF	±5%	GRM55D7U2H333JW31#	
39000pF	±5%	GRM55D7U2H393JW31#				

品名 # 表示包装规格代码。

GRM 系列
GJM 系列
GMA 系列
GMD 系列
GQM 系列
GRJ 系列
GR3 系列
KRM 系列
KR3 系列
LLA 系列
LLL 系列
LLM 系列
LLR 系列
警告 / 注意事項

GRM 系列温度补偿型品名列表

(→ ■ 5.7×5.0mm)

T 最大值	额定 电压	温度特 性代号	静电容量	公差	品名
2.0mm	500Vdc	U2J	47000pF	±5%	GRM55D7U2H473JW31#

www.tocosc.com

GRM 系列

GJM 系列

GMA 系列

GMD 系列

GQM 系列

GRJ 系列

GR3 系列

KRM 系列

KR3 系列

LLA 系列

LLL 系列

LLM 系列

LLR 系列

警告 / 注意事项

品名 # 表示包装规格代码。

GRM 系列高介电常数型品名列表

■ 0.4×0.2mm **超小型**

T 最大值	额定 电压	温度特 性代号	静电容量	公差	品名		
0.22mm	16Vdc	X7R	100pF	±10%	GRM022R71C101KE14#	降额	
				±20%	GRM022R71C101ME14#	降额	
			150pF	±10%	GRM022R71C151KE14#	降额	
				±20%	GRM022R71C151ME14#	降额	
			220pF	±10%	GRM022R71C221KE14#	降额	
				±20%	GRM022R71C221ME14#	降额	
			330pF	±10%	GRM022R71C331KE14#	降额	
				±20%	GRM022R71C331ME14#	降额	
			470pF	±10%	GRM022R71C471KE14#	降额	
				±20%	GRM022R71C471ME14#	降额	
			1000pF	±10%	GRM022R71C102KE14#	降额	
				±20%	GRM022R71C102ME14#	降额	
		10Vdc	X7R	100pF	±10%	GRM022R71A101KA01#	
					±20%	GRM022R71A101MA01#	
				150pF	±10%	GRM022R71A151KA01#	
					±20%	GRM022R71A151MA01#	
				220pF	±10%	GRM022R71A221KA01#	
					±20%	GRM022R71A221MA01#	
				330pF	±10%	GRM022R71A331KA01#	
					±20%	GRM022R71A331MA01#	
				470pF	±10%	GRM022R71A471KA01#	
					±20%	GRM022R71A471MA01#	
				680pF	±10%	GRM022R71A681KA12#	
					±20%	GRM022R71A681MA12#	
	820pF		±10%	GRM022R71A821KA12#			
			±20%	GRM022R71A821MA12#			
	1000pF		±10%	GRM022R71A102KA12#			
			±20%	GRM022R71A102MA12#			
	X5R		100pF	±10%	GRM022R61A101KA01#		
				±20%	GRM022R61A101MA01#		
			150pF	±10%	GRM022R61A151KA01#		
				±20%	GRM022R61A151MA01#		
			220pF	±10%	GRM022R61A221KA01#		
				±20%	GRM022R61A221MA01#		
			330pF	±10%	GRM022R61A331KA01#		
				±20%	GRM022R61A331MA01#		
		470pF	±10%	GRM022R61A471KA01#			
			±20%	GRM022R61A471MA01#			
		680pF	±10%	GRM022R61A681KE19#			
			±20%	GRM022R61A681ME19#			
	X5R	1000pF	±10%	GRM022R61A102KE19#			
			±20%	GRM022R61A102ME19#			
		1500pF	±10%	GRM022R61A152KE19#			
			±20%	GRM022R61A152ME19#			
		2200pF	±10%	GRM022R61A222KE19#			
			±20%	GRM022R61A222ME19#			
		3300pF	±10%	GRM022R61A332KE19#			
			±20%	GRM022R61A332ME19#			
4700pF		±10%	GRM022R61A472KE19#				
		±20%	GRM022R61A472ME19#				
6800pF		±10%	GRM022R61A682KE19#				
		±20%	GRM022R61A682ME19#				

T 最大值	额定 电压	温度特 性代号	静电容量	公差	品名		
0.22mm	10Vdc	X5R	10000pF	±10%	GRM022R61A103KE19#		
				±20%	GRM022R61A103ME19#		
			B	100pF	±10%	GRM022B11A101KA01#	
					±20%	GRM022B11A101MA01#	
			150pF	±10%	GRM022B11A151KA01#		
				±20%	GRM022B11A151MA01#		
			220pF	±10%	GRM022B11A221KA01#		
				±20%	GRM022B11A221MA01#		
			330pF	±10%	GRM022B11A331KA01#		
				±20%	GRM022B11A331MA01#		
			470pF	±10%	GRM022B11A471KA01#		
				±20%	GRM022B11A471MA01#		
		680pF	±10%	GRM022B31A681KE19#			
			±20%	GRM022B31A681ME19#			
		1000pF	±10%	GRM022B31A102KE19#			
			±20%	GRM022B31A102ME19#			
		1500pF	±10%	GRM022B31A152KE19#			
			±20%	GRM022B31A152ME19#			
		2200pF	±10%	GRM022B31A222KE19#			
			±20%	GRM022B31A222ME19#			
		3300pF	±10%	GRM022B31A332KE19#			
			±20%	GRM022B31A332ME19#			
		4700pF	±10%	GRM022B31A472KE19#			
			±20%	GRM022B31A472ME19#			
	6800pF	±10%	GRM022B31A682KE19#				
		±20%	GRM022B31A682ME19#				
	10000pF	±10%	GRM022B31A103KE19#				
		±20%	GRM022B31A103ME19#				
	6.3Vdc	X5R	100pF	±20%	GRM022R60J102ME19#		
				±20%	GRM022R60J152ME19#		
			220pF	±20%	GRM022R60J222ME19#		
				±20%	GRM022R60J332ME19#		
			470pF	±20%	GRM022R60J472ME19#		
				±20%	GRM022R60J682ME19#		
			1000pF	±20%	GRM022R60J103ME19#		
				±20%	GRM022R60J153ME15#	降额	
			2200pF	±10%	GRM022R60J223KE15#	降额	
				±20%	GRM022R60J223ME15#	降额	
			33000pF	±20%	GRM022R60J333ME15#	降额	
				±20%	GRM022R60J473ME15#	降额	
		68000pF	±20%	GRM022R60J683ME15#	降额		
			±20%	GRM022R60J104ME15#	降额		
		B	1000pF	±20%	GRM022B30J102ME19#		
				±20%	GRM022B30J152ME19#		
			2200pF	±20%	GRM022B30J222ME19#		
				±20%	GRM022B30J332ME19#		
			4700pF	±20%	GRM022B30J472ME19#		
				±20%	GRM022B30J682ME19#		
10000pF			±20%	GRM022B30J103ME19#			
			±20%	GRM022B30J104ME15#	降额		
4Vdc			X6T	0.10μF	±20%	GRM022D80G104ME15#	降额
					±20%	GRM022R60G153KE15#	
	X5R			15000pF	±10%	GRM022R60G153ME15#	
					±20%	GRM022R60G223KE15#	
	22000pF	±10%		GRM022R60G223ME15#			
		±20%		GRM022R60G223ME15#			

品名 # 表示包装规格代码。

GRM 系列
GJM 系列
GMA 系列
GMD 系列
GQM 系列
GRJ 系列
GR3 系列
KRM 系列
KR3 系列
LLA 系列
LLL 系列
LLM 系列
LLR 系列
警告 / 注意事项

GRM 系列高介电常数型品名列表

(→ ■ 0.4×0.2mm)

T 最大值	额定 电压	温度特 性代号	静电容量	公差	品名
0.22mm	4Vdc	X5R	33000pF	±10%	GRM022R60G333KE15#
				±20%	GRM022R60G333ME15#
			47000pF	±10%	GRM022R60G473KE15#
				±20%	GRM022R60G473ME15#
			68000pF	±20%	GRM022R60G683ME15#
				0.10μF	±20%
2.5Vdc	X6T	0.10μF	±20%	GRM022D80E104ME15#	

■ 0.6×0.3mm 超小型

T 最大值	额定 电压	温度特 性代号	静电容量	公差	品名		
0.33mm	50Vdc	X7R	100pF	±10%	GRM033R71H101KA12#		
				±20%	GRM033R71H101MA12#		
			150pF	±10%	GRM033R71H151KA12#		
				±20%	GRM033R71H151MA12#		
			220pF	±10%	GRM033R71H221KA12#		
				±20%	GRM033R71H221MA12#		
			330pF	±10%	GRM033R71H331KA12#		
				±20%	GRM033R71H331MA12#		
			470pF	±10%	GRM033R71H471KA12#		
				±20%	GRM033R71H471MA12#		
			680pF	±10%	GRM033R71H681KA12#		
				±20%	GRM033R71H681MA12#		
			1000pF	±10%	GRM033R71H102KA12#		
				±20%	GRM033R71H102MA12#		
			1500pF	±10%	GRM033R71H152KA12#		
				±20%	GRM033R71H152MA12#		
			B	100pF	±10%	GRM033B31H101KA12#	
					±20%	GRM033B31H101MA12#	
				150pF	±10%	GRM033B31H151KA12#	
					±20%	GRM033B31H151MA12#	
				220pF	±10%	GRM033B31H221KA12#	
					±20%	GRM033B31H221MA12#	
				330pF	±10%	GRM033B31H331KA12#	
					±20%	GRM033B31H331MA12#	
		470pF		±10%	GRM033B31H471KA12#		
				±20%	GRM033B31H471MA12#		
		680pF		±10%	GRM033B31H681KA12#		
				±20%	GRM033B31H681MA12#		
		1000pF	±10%	GRM033B31H102KA12#			
			±20%	GRM033B31H102MA12#			
		1500pF	±10%	GRM033B31H152KA12#			
			±20%	GRM033B31H152MA12#			
		35Vdc	X5R	0.10μF	±10%	GRM033R6YA104KE14# <small>降额</small>	
					±20%	GRM033R6YA104ME14# <small>降额</small>	
			25Vdc	X7R	1000pF	±10%	GRM033R71E102KA01#
						±20%	GRM033R71E152KA01#
		2200pF			±10%	GRM033R71E222KA12#	
					±20%	GRM033R71E222MA12#	
		3300pF	±10%	GRM033R71E332KA12#			
			±20%	GRM033R71E332MA12#			
		4700pF	±10%	GRM033R71E472KE14# <small>降额</small>			
			±20%	GRM033R71E472ME14# <small>降额</small>			

T 最大值	额定 电压	温度特 性代号	静电容量	公差	品名	
0.33mm	25Vdc	X7R	6800pF	±10%	GRM033R71E682KE14# <small>降额</small>	
				±20%	GRM033R71E682ME14# <small>降额</small>	
			10000pF	±10%	GRM033R71E103KE14# <small>降额</small>	
				±20%	GRM033R71E103ME14# <small>降额</small>	
			R	100pF	±10%	GRM033R11E101KA01#
					±10%	GRM033R11E151KA01#
				220pF	±10%	GRM033R11E221KA01#
					±10%	GRM033R11E331KA01#
				470pF	±10%	GRM033R11E471KA01#
					±10%	GRM033R11E681KA01#
				1000pF	±10%	GRM033R11E102KA01#
					±10%	GRM033R11E152KA01#
		X6S	0.10μF	±10%	GRM033C81E104KE14# <small>降额</small>	
				±20%	GRM033C81E104ME14# <small>降额</small>	
			4700pF	±10%	GRM033R61E472KA12# <small>降额</small>	
				±20%	GRM033R61E472MA12# <small>降额</small>	
			6800pF	±10%	GRM033R61E682KA12# <small>降额</small>	
				±20%	GRM033R61E682MA12# <small>降额</small>	
		10000pF	±10%	GRM033R61E103KA12# <small>降额</small>		
			±20%	GRM033R61E103MA12# <small>降额</small>		
		B	0.10μF	±10%	GRM033R61E104KE14#	
				±20%	GRM033R61E104ME14#	
			1000pF	±10%	GRM033B11E102KA01#	
				±20%	GRM033B11E102MA01#	
			1500pF	±10%	GRM033B11E152KA01#	
				±20%	GRM033B11E152MA01#	
			2200pF	±10%	GRM033B31E222KA12#	
				±20%	GRM033B31E222MA12#	
			3300pF	±10%	GRM033B31E332KA12#	
				±20%	GRM033B31E332MA12#	
			10000pF	±10%	GRM033B31E103KA12# <small>降额</small>	
				±20%	GRM033B31E103MA12# <small>降额</small>	
		16Vdc	X7R	2200pF	±10%	GRM033R71C222KA88#
					±10%	GRM033R71C332KA88#
				4700pF	±10%	GRM033R71C472KE14#
					±20%	GRM033R71C472ME14#
				6800pF	±10%	GRM033R71C682KE14#
					±20%	GRM033R71C682ME14#
			10000pF	±10%	GRM033R71C103KE14#	
				±20%	GRM033R71C103ME14#	
			X7S	0.10μF	±10%	GRM033C71C104KE14# <small>降额</small>
					±20%	GRM033C71C104ME14# <small>降额</small>
			R	2200pF	±10%	GRM033R11C222KA88#
					±10%	GRM033R11C332KA88#
		X6S	0.10μF	±10%	GRM033C81C104KE14#	
				±20%	GRM033C81C104ME14#	
			10000pF	±10%	GRM033R61C103KA12#	
				±20%	GRM033R61C103MA12#	
X5R	15000pF	±10%	GRM033R61C153KE84# <small>降额</small>			
		±20%	GRM033R61C153ME84# <small>降额</small>			
	22000pF	±10%	GRM033R61C223KE84# <small>降额</small>			
		±20%	GRM033R61C223ME84# <small>降额</small>			
	33000pF	±10%	GRM033R61C333KE84# <small>降额</small>			
		±20%	GRM033R61C333ME84# <small>降额</small>			

品名 # 表示包装规格代码。

GRM 系列
GJM 系列
GMA 系列
GMD 系列
GQM 系列
GRJ 系列
GR3 系列
KRM 系列
KR3 系列
LLA 系列
LLL 系列
LLM 系列
LLR 系列
警告/注意事项

GRM 系列高介电常数型品名列表

(→ ■ 0.6×0.3mm)

T 最大值	额定 电压	温度特 性代号	静电容量	公差	品名			
0.33mm	16Vdc	X5R	47000pF	±10%	GRM033R61C473KE84#	降额		
				±20%	GRM033R61C473ME84#	降额		
			68000pF	±10%	GRM033R61C683KE84#	降额		
				±20%	GRM033R61C683ME84#	降额		
			0.10μF	±10%	GRM033R61C104KE14#			
				±20%	GRM033R61C104ME14#			
			B	2200pF	±10%	GRM033B31C222KA87#		
					±20%	GRM033B31C222MA87#		
				3300pF	±10%	GRM033B31C332KA87#		
					±20%	GRM033B31C332MA87#		
				10000pF	±10%	GRM033B31C103KA12#		
					±20%	GRM033B31C103MA12#		
		15000pF		±10%	GRM033B31C153KE84#	降额		
				±20%	GRM033B31C153ME84#	降额		
		22000pF		±10%	GRM033B31C223KE84#	降额		
				±20%	GRM033B31C223ME84#	降额		
		33000pF		±10%	GRM033B31C333KE84#	降额		
				±20%	GRM033B31C333ME84#	降额		
		47000pF	±10%	GRM033B31C473KE84#	降额			
			±20%	GRM033B31C473ME84#	降额			
		68000pF	±10%	GRM033B31C683KE84#	降额			
			±20%	GRM033B31C683ME84#	降额			
		0.10μF	±10%	GRM033B31C104KE84#	降额			
			±20%	GRM033B31C104ME84#	降额			
		10Vdc	X7R	4700pF	±10%	GRM033R71A472KA01#		
					±20%	GRM033R71A472MA01#		
				6800pF	±10%	GRM033R71A682KA01#		
					±20%	GRM033R71A682MA01#		
				10000pF	±10%	GRM033R71A103KA01#		
					±20%	GRM033R71A103MA01#		
				X7S	0.10μF	±10%	GRM033C71A104KE14#	
						±20%	GRM033C71A104ME14#	
				R	4700pF	±10%	GRM033R11A472KA01#	
						±20%	GRM033R11A472MA01#	
					6800pF	±10%	GRM033R11A682KA01#	
						±20%	GRM033R11A682MA01#	
			10000pF		±10%	GRM033R11A103KA01#		
					±20%	GRM033R11A103MA01#		
			X5R	4700pF	±10%	GRM033R61A472KA01#		
					±20%	GRM033R61A472MA01#		
				6800pF	±10%	GRM033R61A682KA01#		
					±20%	GRM033R61A682MA01#		
				15000pF	±10%	GRM033R61A153KE84#		
					±20%	GRM033R61A153ME84#		
				22000pF	±10%	GRM033R61A223KE84#		
					±20%	GRM033R61A223ME84#		
				33000pF	±10%	GRM033R61A333KE84#		
					±20%	GRM033R61A333ME84#		
47000pF	±10%	GRM033R61A473KE84#						
	±20%	GRM033R61A473ME84#						
68000pF	±10%	GRM033R61A683KE84#						
	±20%	GRM033R61A683ME84#						
0.10μF	±10%	GRM033R61A104KE84#						
	±20%	GRM033R61A104ME84#						

T 最大值	额定 电压	温度特 性代号	静电容量	公差	品名		
0.33mm	10Vdc	X5R	0.22μF	±20%	GRM033R61A224ME90#	降额	
				4700pF	±10%	GRM033B11A472KA01#	
			±20%		GRM033B11A472MA01#		
			6800pF	±10%	GRM033B11A682KA01#		
				±20%	GRM033B11A682MA01#		
			15000pF	±10%	GRM033B31A153KE84#		
				±20%	GRM033B31A153ME84#		
			22000pF	±10%	GRM033B31A223KE84#		
				±20%	GRM033B31A223ME84#		
			33000pF	±10%	GRM033B31A333KE84#		
				±20%	GRM033B31A333ME84#		
			47000pF	±10%	GRM033B31A473KE84#		
		±20%		GRM033B31A473ME84#			
		68000pF	±10%	GRM033B31A683KE84#			
			±20%	GRM033B31A683ME84#			
		0.10μF	±10%	GRM033B31A104KE84#			
			±20%	GRM033B31A104ME84#			
		6.3Vdc	X7R	4700pF	±10%	GRM033R70J472KA01#	
					±20%	GRM033R70J472MA01#	
				6800pF	±10%	GRM033R70J682KA01#	
					±20%	GRM033R70J682MA01#	
				10000pF	±10%	GRM033R70J103KA01#	
					±20%	GRM033R70J103MA01#	
			R	4700pF	±10%	GRM033R10J472KA01#	
					±20%	GRM033R10J472MA01#	
				6800pF	±10%	GRM033R10J682KA01#	
					±20%	GRM033R10J682MA01#	
				10000pF	±10%	GRM033R10J103KA01#	
					±20%	GRM033R10J103MA01#	
		X6S	15000pF	±10%	GRM033C80J153KE01#		
				±20%	GRM033C80J153ME01#		
			22000pF	±10%	GRM033C80J223KE01#		
				±20%	GRM033C80J223ME01#		
			33000pF	±10%	GRM033C80J333KE01#		
				±20%	GRM033C80J333ME01#		
		47000pF	±10%	GRM033C80J473KE19#			
			±20%	GRM033C80J473ME19#			
		X5R	68000pF	±10%	GRM033C80J683KE84#	降额	
				±20%	GRM033C80J683ME84#	降额	
			0.10μF	±10%	GRM033C80J104KE84#	降额	
				±20%	GRM033C80J104ME84#	降额	
			0.22μF	±20%	GRM033C80J224ME90#	降额	
				0.22μF	±20%	GRM033R60J224ME90#	
		B	4700pF		±10%	GRM033B10J472KA01#	
				±20%	GRM033B10J472MA01#		
			6800pF	±10%	GRM033B10J682KA01#		
				±20%	GRM033B10J682MA01#		
			15000pF	±10%	GRM033B10J153KE01#		
±20%	GRM033B10J153ME01#						
22000pF	±10%	GRM033B10J223KE01#					
	±20%	GRM033B10J223ME01#					
33000pF	±10%	GRM033B10J333KE01#					
	±20%	GRM033B10J333ME01#					
4Vdc	X6S	0.22μF	±20%	GRM033C80G224ME90#			

■ 1.0×0.5mm

T 最大值	额定 电压	温度特 性代号	静电容量	公差	品名	
0.22mm	10Vdc	X5R	0.10μF	±10%	GRM152R61A104KE19#	降额
				±20%	GRM152R61A104ME19#	降额
			0.22μF	±10%	GRM152R61A224KE19#	降额

品名 # 表示包装规格代码。

- GRM 系列
- GJM 系列
- GMA 系列
- GMD 系列
- GQM 系列
- GRJ 系列
- GR3 系列
- KRM 系列
- KR3 系列
- L1A 系列
- L1L 系列
- L1M 系列
- L1R 系列
- 警告 / 注意事项

GRM 系列高介电常数型品名列表

(→ ■ 1.0×0.5mm)

T 最大值	额定 电压	温度特 性代号	静电容量	公差	品名		
0.22mm	10Vdc	X5R	0.22μF	±20%	GRM152R61A224ME19#	降额	
			0.10μF	±10%	GRM152B31A104KE19#	降额	
		B	±20%	GRM152B31A104ME19#	降额		
			0.22μF	±10%	GRM152B31A224KE19#	降额	
		±20%	GRM152B31A224ME19#	降额			
			6.3Vdc	X6S	0.10μF	±10%	GRM152C80J104KE19#
	±20%	GRM152C80J104ME19#			降额		
	0.22μF	±10%		GRM152C80J224KE19#	降额		
		±20%		GRM152C80J224ME19#	降额		
	X5R	0.10μF		±10%	GRM152R60J104KE19#		
		±20%		GRM152R60J104ME19#			
	0.22μF	±10%	GRM152R60J224KE19#				
		±20%	GRM152R60J224ME19#				
	0.47μF	±20%	GRM152R60J474ME15#	降额			
		1.0μF	±20%	GRM152R60J105ME15#	降额		
	B	0.10μF	±10%	GRM152B30J104KE19#			
			±20%	GRM152B30J104ME19#			
		0.22μF	±10%	GRM152B30J224KE19#			
			±20%	GRM152B30J224ME19#			
		0.47μF	±20%	GRM152B30J474ME15#	降额		
			4Vdc	X7T	0.10μF	±10%	GRM152D70G104KE15#
	±20%	GRM152D70G104ME15#			降额		
	0.22μF	±10%		GRM152D70G224KE15#	降额		
		±20%		GRM152D70G224ME15#	降额		
	X6S	0.10μF		±10%	GRM152C80G104KE19#		
		±20%		GRM152C80G104ME19#			
	0.22μF	±10%	GRM152C80G224KE19#				
		±20%	GRM152C80G224ME19#				
	X6T	0.47μF	±20%	GRM152D80G474ME15#			
		1.0μF	±20%	GRM152D80G105ME15#	降额		
	X5R	1.0μF	±20%	GRM152R60G105ME15#			
		2.5Vdc	X7T	0.10μF	±10%	GRM152D70E104KE19#	
	±20%			GRM152D70E104ME19#			
	0.22μF		±10%	GRM152D70E224KE19#			
			±20%	GRM152D70E224ME19#			
	0.3mm		50Vdc	X7R	220pF	±10%	GRM15XR71H221KA86#
330pF					±10%	GRM15XR71H331KA86#	
470pF		±10%			GRM15XR71H471KA86#		
680pF		±10%			GRM15XR71H681KA86#		
1000pF		±10%			GRM15XR71H102KA86#		
1500pF		±10%			GRM15XR71H152KA86#		
R	220pF	±10%	GRM15XR11H221KA86#				
	330pF	±10%	GRM15XR11H331KA86#				
	470pF	±10%	GRM15XR11H471KA86#				
	680pF	±10%	GRM15XR11H681KA86#				
	1000pF	±10%	GRM15XR11H102KA86#				
	1500pF	±10%	GRM15XR11H152KA86#				
B	220pF	±10%	GRM15XB11H221KA86#				
	±20%	GRM15XB11H221MA86#					
	330pF	±10%	GRM15XB11H331KA86#				
	±20%	GRM15XB11H331MA86#					
	470pF	±10%	GRM15XB11H471KA86#				
	±20%	GRM15XB11H471MA86#					
680pF	±10%	GRM15XB11H681KA86#					

T 最大值	额定 电压	温度特 性代号	静电容量	公差	品名			
0.3mm	50Vdc	B	680pF	±20%	GRM15XB11H681MA86#			
			1000pF	±10%	GRM15XB11H102KA86#			
			±20%	GRM15XB11H102MA86#				
			1500pF	±10%	GRM15XB11H152KA86#			
			±20%	GRM15XB11H152MA86#				
			25Vdc	X7R	2200pF	±10%	GRM15XR71E222KA86#	
	±20%	GRM15XR71E222MA86#						
	B	2200pF		±10%	GRM15XB11E222KA86#			
		±20%		GRM15XB11E222MA86#				
	16Vdc	X7R		3300pF	±10%	GRM15XR71C332KA86#		
				±20%	GRM15XR71C332MA86#			
			4700pF	±10%	GRM15XR71C472KA86#			
		±20%	GRM15XR71C472MA86#					
			6800pF	±10%	GRM15XR71C682KA86#			
			±20%	GRM15XR71C682MA86#				
	B	10000pF	±10%	GRM15XR71C103KA86#				
		±20%	GRM15XR71C103MA86#					
		3300pF	±10%	GRM15XB11C332KA86#				
		±20%	GRM15XB11C332MA86#					
		4700pF	±10%	GRM15XB11C472KA86#				
		±20%	GRM15XB11C472MA86#					
	6800pF	±10%	GRM15XB11C682KA86#					
		±20%	GRM15XB11C682MA86#					
		10000pF	±10%	GRM15XB11C103KA86#				
		±20%	GRM15XB11C103MA86#					
		10Vdc	X5R	15000pF	±10%	GRM15XR61A153KA86#		
				±20%	GRM15XR61A153MA86#			
	22000pF		±10%	GRM15XR61A223KA86#				
			±20%	GRM15XR61A223MA86#				
	33000pF		±10%	GRM15XR61A333KA86#				
			±20%	GRM15XR61A333MA86#				
	0.33mm	10Vdc	X5R	1.0μF	±20%	GRM153R61A105ME95#	降额	
				B	1.0μF	±20%	GRM153B31A105ME95#	降额
		6.3Vdc	X6T	1.0μF	±20%	GRM153D80J105ME95#	降额	
				X5R	1.0μF	±20%	GRM153R60J105ME95#	
		B	1.0μF	±20%	GRM153B30J105ME95#			
4Vdc			X6T	1.0μF	±20%	GRM153D80G105ME95#		
0.55mm	100Vdc	X7R	220pF	±10%	GRM155R72A221KA01#			
			330pF	±10%	GRM155R72A331KA01#			
			470pF	±10%	GRM155R72A471KA01#			
			680pF	±10%	GRM155R72A681KA01#			
			1000pF	±10%	GRM155R72A102KA01#			
			1500pF	±10%	GRM155R72A152KA01#			
			2200pF	±10%	GRM155R72A222KA01#			
			3300pF	±10%	GRM155R72A332KA01#			
			4700pF	±10%	GRM155R72A472KA01#			
			50Vdc	X7R	220pF	±10%	GRM155R71H221KA01#	
					330pF	±10%	GRM155R71H331KA01#	
					470pF	±10%	GRM155R71H471KA01#	
	680pF	±10%			GRM155R71H681KA01#			
	1000pF	±10%			GRM155R71H102KA01#			
	1500pF	±10%			GRM155R71H152KA01#			
	2200pF	±10%			GRM155R71H222KA01#			
	3300pF	±10%			GRM155R71H332KA01#			

品名 # 表示包装规格代码。

GRM 系列
GJM 系列
GMA 系列
GMD 系列
GQM 系列
GRJ 系列
GR3 系列
KRM 系列
KRL 系列
KRR 系列
LLA 系列
LLL 系列
LLM 系列
LLR 系列
警告/注意事项

GRM 系列高介电常数型品名列表

(→ ■ 1.0×0.5mm)

T 最大值	额定 电压	温度特 性代号	静电容量	公差	品名	
0.55mm	50Vdc	X7R	4700pF	±10%	GRM155R71H472KA01#	
			6800pF	±10%	GRM155R71H682KA88#	
			10000pF	±10%	GRM155R71H103KA88#	
			15000pF	±10%	GRM155R71H153KA12#	
			22000pF	±10%	GRM155R71H223KA12#	
			33000pF	±10%	GRM155R71H333KE14#	
				±20%	GRM155R71H333ME14#	
			47000pF	±10%	GRM155R71H473KE14#	
				±20%	GRM155R71H473ME14#	
			68000pF	±10%	GRM155R71H683KE14#	
				±20%	GRM155R71H683ME14#	
			0.10μF	±10%	GRM155R71H104KE14#	
				±20%	GRM155R71H104ME14#	
			R	220pF	±10%	GRM155R11H221KA01#
				330pF	±10%	GRM155R11H331KA01#
				470pF	±10%	GRM155R11H471KA01#
				680pF	±10%	GRM155R11H681KA01#
				1000pF	±10%	GRM155R11H102KA01#
		1500pF		±10%	GRM155R11H152KA01#	
		2200pF		±10%	GRM155R11H222KA01#	
		3300pF		±10%	GRM155R11H332KA01#	
		4700pF		±10%	GRM155R11H472KA01#	
		6800pF		±10%	GRM155R11H682KA88#	
		10000pF		±10%	GRM155R11H103KA88#	
		33000pF		±10%	GRM155R11H333KE14#	
				±20%	GRM155R11H333ME14#	
		47000pF		±10%	GRM155R11H473KE14#	
				±20%	GRM155R11H473ME14#	
		68000pF		±10%	GRM155R11H683KE14#	
				±20%	GRM155R11H683ME14#	
		X6S		33000pF	±10%	GRM155C81H333KE14#
				±20%	GRM155C81H333ME14#	
			47000pF	±10%	GRM155C81H473KE14#	
				±20%	GRM155C81H473ME14#	
			68000pF	±10%	GRM155C81H683KE14#	
				±20%	GRM155C81H683ME14#	
		X5R	33000pF	±10%	GRM155R61H333KE14#	
				±20%	GRM155R61H333ME14#	
			47000pF	±10%	GRM155R61H473KE14#	
				±20%	GRM155R61H473ME14#	
			68000pF	±10%	GRM155R61H683KE14#	
				±20%	GRM155R61H683ME14#	
		0.10μF	±10%	GRM155R61H104KE14#		
				±20%	GRM155R61H104ME14#	
			B	220pF	±10%	GRM155B11H221KA01#
					±20%	GRM155B11H221MA01#
				330pF	±10%	GRM155B11H331KA01#
					±20%	GRM155B11H331MA01#
		470pF		±10%	GRM155B11H471KA01#	
				±20%	GRM155B11H471MA01#	
		680pF		±10%	GRM155B11H681KA01#	
				±20%	GRM155B11H681MA01#	
		1000pF		±10%	GRM155B11H102KA01#	
				±20%	GRM155B11H102MA01#	
1500pF	±10%	GRM155B11H152KA01#				
	±20%	GRM155B11H152MA01#				
2200pF	±10%	GRM155B11H222KA01#				
	±20%	GRM155B11H222MA01#				
3300pF	±10%	GRM155B11H332KA01#				
	±20%	GRM155B11H332MA01#				

T 最大值	额定 电压	温度特 性代号	静电容量	公差	品名	
0.55mm	50Vdc	B	4700pF	±10%	GRM155B11H472KA01#	
				±20%	GRM155B11H472MA01#	
			6800pF	±10%	GRM155B31H682KA88#	
				±20%	GRM155B31H682MA88#	
			10000pF	±10%	GRM155B31H103KA88#	
				±20%	GRM155B31H103MA88#	
			15000pF	±10%	GRM155B31H153KA12#	
				±20%	GRM155B31H153MA12#	
			22000pF	±10%	GRM155B31H223KA12#	
				±20%	GRM155B31H223MA12#	
			0.10μF	±10%	GRM155B31H104KE14#	
				±20%	GRM155B31H104ME14#	
		35Vdc	X6S	0.22μF	±10%	GRM155C8YA224KE01#
					±20%	GRM155C8YA224ME01#
				0.22μF	±10%	GRM155R6YA224KE01#
				±20%	GRM155R6YA224ME01#	
			X5R	0.47μF	±10%	GRM155R6YA474KE01#
					±20%	GRM155R6YA474ME01#
	25Vdc	X7R	10000pF	±10%	GRM155R71E103KA01#	
			15000pF	±10%	GRM155R71E153KA61#	
			22000pF	±10%	GRM155R71E223KA61#	
			33000pF	±10%	GRM155R71E333KA88#	
			47000pF	±10%	GRM155R71E473KA88#	
			68000pF	±10%	GRM155R71E683KE14#	
		0.10μF	±10%	GRM155R71E104KE14#		
				±20%	GRM155R71E104ME14#	
			R	6800pF	±10%	GRM155R11E682KA01#
				10000pF	±10%	GRM155R11E103KA01#
				15000pF	±10%	GRM155R11E153KA61#
				22000pF	±10%	GRM155R11E223KA61#
		33000pF		±10%	GRM155R11E333KA88#	
		47000pF		±10%	GRM155R11E473KA88#	
		X6S	0.22μF	±10%	GRM155C81E224KE01#	
				±20%	GRM155C81E224ME01#	
			X5R	68000pF	±10%	GRM155R61E683KA87#
				±20%	GRM155R61E683MA87#	
	0.10μF	±10%		GRM155R61E104KA87#		
		±20%	GRM155R61E104MA87#			
	0.22μF	±10%	GRM155R61E224KE01#			
			±20%	GRM155R61E224ME01#		
		0.47μF	±10%	GRM155R61E474KE01#		
			±20%	GRM155R61E474ME01#		
1.0μF	±10%		GRM155R61E105KA12#			
	±20%	GRM155R61E105MA12#				
B	10000pF	±10%	GRM155B11E103KA01#			
		±20%	GRM155B11E103MA01#			
	15000pF	±10%	GRM155B11E153KA61#			
		±20%	GRM155B11E153MA61#			
	22000pF	±10%	GRM155B11E223KA61#			
		±20%	GRM155B11E223MA61#			
	33000pF	±10%	GRM155B31E333KA87#			
		±20%	GRM155B31E333MA87#			
47000pF	±10%	GRM155B31E473KA87#				

品名 # 表示包装规格代码。

GRM 系列
GJM 系列
GMA 系列
GMD 系列
GQM 系列
GRJ 系列
GR3 系列
KRM 系列
KR3 系列
LLA 系列
LLL 系列
LLM 系列
LLR 系列
警告 / 注意事項

GRM 系列高介电常数型品名列表

(→ ■ 1.0×0.5mm)

T 最大值	额定 电压	温度特 性代号	静电容量	公差	品名		
0.55mm	25Vdc	B	47000pF	±20%	GRM155B31E473MA87#		
				±10%	GRM155B31E683KA87#		
				±20%	GRM155B31E683MA87#		
			0.10μF	±10%	GRM155B31E104KA87#		
				±20%	GRM155B31E104MA87#		
				1.0μF	±10%	GRM155B31E105KA12#	降額
		±20%	GRM155B31E105MA12#		降額		
		16Vdc	X7R	68000pF	±10%	GRM155R71C683KA88#	
					±10%	GRM155R71C154KA12#	
					±10%	GRM155R71C224KA12#	
				0.22μF	±10%	GRM155R11C683KA88#	
					±10%	GRM155C81C474KE01#	
	±20%				GRM155C81C474ME01#		
	X6S		0.47μF	±10%	GRM155R61C224KA12#		
				±20%	GRM155R61C224MA12#		
				±10%	GRM155R61C474KE01#		
			0.47μF	±10%	GRM155R61C474ME01#		
				±20%	GRM155R61C105KA12#		
				±20%	GRM155R61C105MA12#		
	X5R		0.22μF	±10%	GRM155R61C105KA12#		
				±20%	GRM155R61C105MA12#		
				±10%	GRM155R61C474KE01#		
			0.47μF	±10%	GRM155R61C474ME01#		
				±20%	GRM155R61C105KA12#		
				±20%	GRM155R61C105MA12#		
	B	1.0μF	±10%	GRM155B31C105KA12#			
			±20%	GRM155B31C105MA12#			
			±10%	GRM155R71A224KE01#			
		10Vdc	X7R	0.22μF	±10%	GRM155R71A224ME01#	
					±20%	GRM155R71A224ME01#	
					±10%	GRM155R71A474KE01#	
	0.47μF			±10%	GRM155R71A474ME01#		
				±20%	GRM155R71A474ME01#		
				1.0μF	±10%	GRM155C81A105KA12#	
	±20%		GRM155C81A105MA12#				
	X6S		1.0μF	±10%	GRM155R61A154KE19#		
				±20%	GRM155R61A154ME19#		
				±10%	GRM155R61A224KE19#		
			X5R	0.15μF	±10%	GRM155R61A224ME19#	
					±20%	GRM155R61A224ME19#	
		±10%			GRM155R61A334KE15#		
	0.33μF	±10%		GRM155R61A334ME15#			
		±20%		GRM155R61A334ME15#			
		±10%		GRM155R61A474KE15#			
	0.47μF	±10%	GRM155R61A474ME15#				
±20%		GRM155R61A474ME15#					
0.68μF		±10%	GRM155R61A684KE15#				
		±20%	GRM155R61A684ME15#				
B		0.15μF	±10%	GRM155B31A154KE18#			
			±20%	GRM155B31A154ME18#			
	0.22μF		±10%	GRM155B31A224KE18#			
			±20%	GRM155B31A224ME18#			
	0.33μF		±10%	GRM155B31A334KE14#			
			±20%	GRM155B31A334ME14#			
	0.47μF	±10%	GRM155B31A474KE14#				
		±20%	GRM155B31A474ME14#				
	0.68μF	±10%	GRM155B31A684KE15#				
		±20%	GRM155B31A684ME15#				
		2.2μF	±10%	GRM155B31A225KE95#	降額		
			±20%	GRM155B31A225ME95#	降額		
		6.3Vdc	X7R	1.0μF	±10%	GRM155R70J105KA12#	降額
					±20%	GRM155R70J105MA12#	降額
	X6S			2.2μF	±10%	GRM155C80J225KE95#	降額
			±20%		GRM155C80J225ME95#	降額	
			X5R	0.15μF	±10%	GRM155R60J154KE01#	
	±10%				GRM155R60J154ME01#		

T 最大值	额定 电压	温度特 性代号	静电容量	公差	品名		
0.55mm	6.3Vdc	X5R	0.15μF	±20%	GRM155R60J154ME01#		
				±10%	GRM155R60J224KE01#		
				±20%	GRM155R60J224ME01#		
			0.22μF	±10%	GRM155R60J334KE01#		
				±20%	GRM155R60J334ME01#		
				0.47μF	±10%	GRM155R60J474KE19#	
			±20%		GRM155R60J474ME19#		
			B	0.68μF	±10%	GRM155R60J684KE19#	
					±20%	GRM155R60J684ME19#	
					0.15μF	±10%	GRM155B10J154KE01#
				±20%		GRM155B10J154ME01#	
				0.22μF		±10%	GRM155B10J224KE01#
		±20%			GRM155B10J224ME01#		
		0.33μF	±10%		GRM155B10J334KE01#		
			±20%	GRM155B10J334ME01#			
			0.47μF	±10%	GRM155B30J474KE18#		
		±20%		GRM155B30J474ME18#			
		0.68μF		±10%	GRM155B30J684KE18#		
	±20%		GRM155B30J684ME18#				
	2.2μF		±10%	GRM155B30J225KE95#			
		±20%	GRM155B30J225ME95#				
		4Vdc	X7R	1.0μF	±10%	GRM155R70G105KA12#	
	±20%				GRM155R70G105MA12#		
	X5R			1.0μF	±10%	GRM155R6YA105KE11#	降額
			±20%		GRM155R6YA105ME11#	降額	
			X6S	1.0μF	±10%	GRM155C81E105KE11#	降額
	±20%				GRM155C81E105ME11#	降額	
	25Vdc	X6S	1.0μF	±10%	GRM155C81C105KE11#		
				±20%	GRM155C81C105ME11#		
			X5R	4.7μF	±10%	GRM155R60J475ME47#	降額
		±20%			GRM155B30J475ME47#	降額	
		B		4.7μF	±10%	GRM155R60G475ME47#	
			±20%		GRM155B30G475ME47#		
	X6T		4.7μF	±10%	GRM155D80E475ME47#	降額	
		±20%		GRM155D80E475ME47#	降額		
		0.65mm	6.3Vdc	X6S	4.7μF	±20%	GRM155C80J475MEAA#
	X5R					4.7μF	±20%
				X6S	2.2μF		±10%
	16Vdc		X6S			2.2μF	±10%
				±20%	GRM155C81C225ME11#		
			X5R	2.2μF	±10%	GRM155R61C225KE11#	
	±20%				GRM155R61C225ME11#		
	10Vdc			X7S	2.2μF	±10%	GRM155C71A225KE11#
			±20%			GRM155C71A225ME11#	
		X6S	2.2μF	±10%	GRM155C81A225KE11#		
±20%	GRM155C81A225ME11#						
6.3Vdc	X7S		2.2μF	±10%	GRM155C70J225KE11#		
		±20%		GRM155C70J225ME11#			
	4Vdc	X5R	10μF	±20%	GRM155R60G106ME44#		
X5R				10μF	±20%	GRM155R60E106ME16#	

品名 # 表示包装规格代码。

GRM 系列
GJM 系列
GMA 系列
GMD 系列
GQM 系列
GRJ 系列
GR3 系列
KRM 系列
KRP 系列
LLA 系列
LLL 系列
LLM 系列
LLR 系列
警告/注意事项

GRM 系列高介电常数型品名列表

■ 1.6×0.8mm

T 最大值	额定 电压	温度特 性代号	静电容量	公差	品名							
0.5mm	25Vdc	X5R	1.0μF	±10%	GRM185R61E105KA12#	降额						
				±20%	GRM185R61E105MA12#	降额						
				B	1.0μF	±10%	GRM185B31E105KA12#	降额				
			±20%			GRM185B31E105MA12#	降额					
			16Vdc			X5R	1.0μF	±10%	GRM185R61C105KE44#			
				±20%	GRM185R61C105ME44#							
		B		1.0μF	±10%			GRM185B31C105KE43#				
					±20%	GRM185B31C105ME43#						
					6.3Vdc	X5R	10μF	±20%	GRM185R60J106ME15#	降额		
		4Vdc		X5R				10μF	±20%	GRM185R60G106ME15#		
			0.55mm						16Vdc	X5R	4.7μF	±10%
						±20%	GRM185R61C475ME11#					
	10Vdc	X6S		4.7μF		±10%	GRM185C81A475KE11#	降额				
						±20%	GRM185C81A475ME11#	降额				
				X5R	4.7μF	±10%	GRM185R61A475KE11#					
	±20%	GRM185R61A475ME11#										
	6.3Vdc	X7T	4.7μF			±20%	GRM185D70J475ME11#	降额				
				X6S	4.7μF	±20%	GRM185C80J475ME11#					
		0.9mm	250Vdc			X7R	220pF	±10%	GRM188R72E221KW07#			
	330pF			±10%	GRM188R72E331KW07#							
	470pF			±10%	GRM188R72E471KW07#							
	680pF			±10%	GRM188R72E681KW07#							
	1000pF			±10%	GRM188R72E102KW07#							
	1500pF			±10%	GRM188R72E152KW07#							
2200pF	±10%			GRM188R72E222KW07#								
200Vdc	X7R			220pF	±10%		GRM188R72D221KW07#					
				330pF	±10%		GRM188R72D331KW07#					
				470pF	±10%		GRM188R72D471KW07#					
				680pF	±10%		GRM188R72D681KW07#					
				1000pF	±10%		GRM188R72D102KW07#					
				1500pF	±10%		GRM188R72D152KW07#					
				2200pF	±10%		GRM188R72D222KW07#					
100Vdc	X7R			220pF	±10%	GRM188R72A221KA01#						
				330pF	±10%	GRM188R72A331KA01#						
				470pF	±10%	GRM188R72A471KA01#						
				680pF	±10%	GRM188R72A681KA01#						
				1000pF	±10%	GRM188R72A102KA01#						
				1500pF	±10%	GRM188R72A152KA01#						
				2200pF	±10%	GRM188R72A222KA01#						
			3300pF	±10%	GRM188R72A332KA01#							
			4700pF	±10%	GRM188R72A472KA01#							
			6800pF	±10%	GRM188R72A682KA01#							
			10000pF	±10%	GRM188R72A103KA01#							
			15000pF	±10%	GRM188R72A153KAC4#							
					GRM188R72A153MAC4#							
			22000pF	±10%	GRM188R72A223KAC4#							
GRM188R72A223MAC4#												
50Vdc	X7R		0.10μF	±10%	GRM188R72A104KA35#							
				50Vdc	X7R	220pF	±10%	GRM188R71H221KA01#				
						330pF	±10%	GRM188R71H331KA01#				
						470pF	±10%	GRM188R71H471KA01#				
						680pF	±10%	GRM188R71H681KA01#				

T 最大值	额定 电压	温度特 性代号	静电容量	公差	品名			
0.9mm	50Vdc	X7R	1000pF	±10%	GRM188R71H102KA01#			
			1500pF	±10%	GRM188R71H152KA01#			
			2200pF	±10%	GRM188R71H222KA01#			
			3300pF	±10%	GRM188R71H332KA01#			
			4700pF	±10%	GRM188R71H472KA01#			
			6800pF	±10%	GRM188R71H682KA01#			
			10000pF	±10%	GRM188R71H103KA01#			
			15000pF	±10%	GRM188R71H153KA01#			
			22000pF	±10%	GRM188R71H223KA01#			
			33000pF	±10%	GRM188R71H333KA61#			
			47000pF	±10%	GRM188R71H473KA61#			
			68000pF	±10%	GRM188R71H683KA93#			
			0.10μF	±10%	GRM188R71H104KA93#			
					0.15μF	±10%	GRM188R71H154KAC4#	
			±20%	GRM188R71H154MAC4#				
				0.22μF	±10%	GRM188R71H224KAC4#		
			±20%			GRM188R71H224MAC4#		
				R	220pF	±10%	GRM188R11H221KA01#	
			330pF		±10%	GRM188R11H331KA01#		
			470pF		±10%	GRM188R11H471KA01#		
			680pF		±10%	GRM188R11H681KA01#		
			1000pF		±10%	GRM188R11H102KA01#		
			1500pF		±10%	GRM188R11H152KA01#		
			2200pF		±10%	GRM188R11H222KA01#		
			3300pF		±10%	GRM188R11H332KA01#		
			4700pF		±10%	GRM188R11H472KA01#		
			6800pF		±10%	GRM188R11H682KA01#		
			10000pF		±10%	GRM188R11H103KA01#		
			15000pF		±10%	GRM188R11H153KA01#		
			22000pF		±10%	GRM188R11H223KA01#		
			33000pF		±10%	GRM188R11H333KA61#		
			47000pF		±10%	GRM188R11H473KA61#		
			68000pF		±10%	GRM188R11H683KA93#		
			0.10μF		±10%	GRM188R11H104KA93#		
			X5R		0.22μF	±10%	GRM188R61H224KAC4#	
				0.47μF	±10%	GRM188R61H474KA12#		
						±20%	GRM188R61H474MA12#	
				1.0μF	±10%	GRM188R61H105KAAL#		
						±20%	GRM188R61H105MAAL#	
				B	220pF	±10%	GRM188B11H221KA01#	
							±20%	GRM188B11H221MA01#
					330pF	±10%	GRM188B11H331KA01#	
							±20%	GRM188B11H331MA01#
					470pF	±10%	GRM188B11H471KA01#	
							±20%	GRM188B11H471MA01#
					680pF	±10%	GRM188B11H681KA01#	
							±20%	GRM188B11H681MA01#
					1000pF	±10%	GRM188B11H102KA01#	
							±20%	GRM188B11H102MA01#
					1500pF	±10%	GRM188B11H152KA01#	
							±20%	GRM188B11H152MA01#
					2200pF	±10%	GRM188B11H222KA01#	
			±20%				GRM188B11H222MA01#	
			3300pF		±10%	GRM188B11H332KA01#		

品名 # 表示包装规格代码。

GRM 系列
GJM 系列
GMA 系列
GMD 系列
GQM 系列
GRJ 系列
GR3 系列
KRM 系列
KR3 系列
LLA 系列
LLL 系列
LLM 系列
LLR 系列
警告 / 注意事項

GRM 系列高介电常数型品名列表

(→ ■ 1.6×0.8mm)

T 最大值	额定 电压	温度特 性代号	静电容量	公差	品名		
0.9mm	50Vdc	B	3300pF	±20%	GRM188B11H332MA01#		
			4700pF	±10%	GRM188B11H472KA01#		
				±20%	GRM188B11H472MA01#		
			6800pF	±10%	GRM188B11H682KA01#		
				±20%	GRM188B11H682MA01#		
			10000pF	±10%	GRM188B11H103KA01#		
				±20%	GRM188B11H103MA01#		
			15000pF	±10%	GRM188B11H153KA01#		
				±20%	GRM188B11H153MA01#		
			22000pF	±10%	GRM188B11H223KA01#		
				±20%	GRM188B11H223MA01#		
			33000pF	±10%	GRM188B11H333KA61#		
				±20%	GRM188B11H333MA61#		
			47000pF	±10%	GRM188B11H473KA61#		
				±20%	GRM188B11H473MA61#		
			68000pF	±10%	GRM188B31H683KA92#		
				±20%	GRM188B31H683MA92#		
			0.10μF	±10%	GRM188B31H104KA92#		
				±20%	GRM188B31H104MA92#		
			0.15μF	±10%	GRM188B31H154KAC4#		
				±20%	GRM188B31H154MAC4#		
			0.22μF	±10%	GRM188B31H224KAC4#		
				±20%	GRM188B31H224MAC4#		
			1.0μF	±10%	GRM188B31H105KAAL#		
				±20%	GRM188B31H105MAAL#		
			25Vdc	X7R	33000pF	±10%	GRM188R71E333KA01#
					47000pF	±10%	GRM188R71E473KA01#
					68000pF	±10%	GRM188R71E683KA01#
					0.15μF	±10%	GRM188R71E154KA01#
						±20%	GRM188R71E154MA12#
					0.22μF	±10%	GRM188R71E224KA88#
						±20%	GRM188R71E224MA12#
					0.47μF	±10%	GRM188R71E474KA12#
						±20%	GRM188R71E474MA12#
					1.0μF	±10%	GRM188R71E105KA12#
						±20%	GRM188R71E105MA12#
R	33000pF	±10%			GRM188R11E333KA01#		
	47000pF	±10%			GRM188R11E473KA01#		
	68000pF	±10%			GRM188R11E683KA01#		
	0.15μF	±10%			GRM188R11E154KA01#		
	0.22μF	±10%			GRM188R11E224KA88#		
	2.2μF	±10%			GRM188R11E225KE14#		
X5R	0.22μF	±10%			GRM188R61E224KA88#		
	0.47μF	±10%			GRM188R61E474KA12#		
		±20%			GRM188R61E474MA12#		
	0.68μF	±10%			GRM188R61E684KA75#		
		±20%			GRM188R61E684MA75#		
	1.0μF	±10%			GRM188R61E105KA12#		
±20%		GRM188R61E105MA12#					
B	10000pF	±10%			GRM188B11E103KA01#		
		±20%			GRM188B11E103MA01#		
	15000pF	±10%			GRM188B11E153KA01#		
		±20%			GRM188B11E153MA01#		
	22000pF	±10%			GRM188B11E223KA01#		
		±20%			GRM188B11E223MA01#		

T 最大值	额定 电压	温度特 性代号	静电容量	公差	品名		
0.9mm	25Vdc	B	33000pF	±10%	GRM188B11E333KA01#		
				±20%	GRM188B11E333MA01#		
			47000pF	±10%	GRM188B11E473KA01#		
				±20%	GRM188B11E473MA01#		
			68000pF	±10%	GRM188B11E683KA01#		
				±20%	GRM188B11E683MA01#		
			0.10μF	±10%	GRM188B11E104KA01#		
				±20%	GRM188B11E104MA01#		
			0.15μF	±10%	GRM188B11E154KA01#		
				±20%	GRM188B11E154MA12#		
			0.22μF	±10%	GRM188B31E224KA87#		
				±20%	GRM188B31E224MA12#		
			0.47μF	±10%	GRM188B31E474KA75#		
				±20%	GRM188B31E474MA75#		
			0.68μF	±10%	GRM188B31E684KA75#		
				±20%	GRM188B31E684MA75#		
			1.0μF	±10%	GRM188B31E105KA75#		
				±20%	GRM188B31E105MA75#		
			2.2μF	±10%	GRM188B31E225KA12#		
				±20%	GRM188B31E225MA12#		
			16Vdc	X7R	0.15μF	±10%	GRM188R71C154KA01#
					0.22μF	±10%	GRM188R71C224KA01#
					0.33μF	±10%	GRM188R71C334KA01#
					0.47μF	±10%	GRM188R71C474KA88#
	1.0μF	±10%			GRM188R71C105KE15#		
		±20%			GRM188R71C105ME15#		
	X7S	0.68μF		±10%	GRM188C71C684KA12#		
		±20%		GRM188C71C684MA12#			
	R	0.33μF		±10%	GRM188R11C334KA01#		
		0.47μF		±10%	GRM188R11C474KA88#		
		X6S		2.2μF	±10%	GRM188C81C225KA12#	
				±20%	GRM188C81C225MA12#		
		X5R	0.68μF	±10%	GRM188R61C684KA75#		
			±20%	GRM188R61C684MA75#			
	B	2.2μF	±10%	GRM188R61C225KE15#			
		±20%	GRM188R61C225MA12#				
	10Vdc	X7R	0.33μF	±10%	GRM188R71A334KA61#		
			±20%	GRM188R71A334MA61#			
			0.68μF	±10%	GRM188R71A684KA61#		
				±20%	GRM188R71A684MA61#		
			2.2μF	±10%	GRM188R71A225KE15#		
				±20%	GRM188R71A225ME15#		
		X7T	2.2μF	±10%	GRM188D71A225KE34#		
			±20%	GRM188D71A225ME34#			
		X5R	0.33μF	±10%	GRM188R61A334KA61#		
			±20%	GRM188R61A334MA61#			
		B	0.33μF	±10%	GRM188B11A334KA61#		
			±20%	GRM188B11A334MA61#			
6.3Vdc	B	10μF	±20%	GRM188B30J106ME47#			
0.95mm	25Vdc	X5R	4.7μF	±10%	GRM188R61E475KE11#		
			±20%	GRM188R61E475ME11#			
16Vdc	X6S	4.7μF	±10%	GRM188C81C475KE11#			

品名 # 表示包装规格代码。

GRM 系列
GJM 系列
GMA 系列
GMD 系列
GQM 系列
GRJ 系列
GR3 系列
KRM 系列
KR3 系列
LLA 系列
LLL 系列
LLM 系列
LLR 系列
警告/注意事项

GRM 系列高介电常数型品名列表

(→ ■ 1.6×0.8mm)

T 最大值	额定 电压	温度特 性代号	静电容量	公差	品名		
0.95mm	16Vdc	X6S	4.7μF	±20%	GRM188C81C475ME11#		
			X5R	4.7μF	±10%	GRM188R61C475KE11#	
					±20%	GRM188R61C475ME11#	
		B	10μF	±10%	GRM188R61C106KAAL#		
				±20%	GRM188R61C106MAAL#		
				±20%	GRM188B31C475KAAJ# 降额		
	10Vdc	X7S	4.7μF	±10%	GRM188C71A475KE11#		
				±20%	GRM188C71A475ME11#		
			X5R	10μF	±10%	GRM188R61A106KAAL#	
				±20%	GRM188R61A106MAAL#		
				±20%	GRM188B31A106ME69# 降额		
		1.0mm	50Vdc	X5R	2.2μF	±10%	GRM188R61H225KE11#
	±20%				GRM188R61H225ME11#		
X6S	2.2μF				±10%	GRM188C8YA225KE11#	
				±20%	GRM188C8YA225ME11#		
	X5R			4.7μF	±10%	GRM188R6YA475KE15#	
				±20%	GRM188R6YA475ME15#		
25Vdc			X7S	2.2μF	±10%	GRM188C71E225KE11#	
				±20%	GRM188C71E225ME11#		
	X6S			2.2μF	±10%	GRM188C81E225KE11#	
				±20%	GRM188C81E225ME11#		
			4.7μF	±10%	GRM188C81E475KE11# 降额		
				±20%	GRM188C81E475ME11# 降额		
X5R	10μF			±20%	GRM188R61E106MA73#		
	16Vdc		X7S	2.2μF	±10%	GRM188C71C225KE11#	
					±20%	GRM188C71C225ME11#	
X6S			10μF	±20%	GRM188C81C106MA73#		
	10Vdc		X7T	10μF	±20%	GRM188D71A106MA73#	
X5R				22μF	±20%	GRM188R60J226MEA0# 降额	
				B	22μF	±20%	GRM188B30J226MEA0# 降额
			4Vdc		X6S	22μF	±20%
X5R						22μF	±20%
				B	22μF	±20%	GRM188B30G226MEA0#

■ 2.0×1.25mm

T 最大值	额定 电压	温度特 性代号	静电容量	公差	品名
0.7mm	16Vdc	X6S	1.0μF	±10%	GRM216C81C105KA12#
0.95mm	100Vdc	X7R	10000pF	±10%	GRM219R72A103KA01#
				±20%	GRM219R72A103MA01#
			X7R	10000pF	±10%
				±20%	GRM219R71H103MA01#
		15000pF		±10%	GRM219R71H153KA01#
				±20%	GRM219R71H153MA01#
	33000pF		±10%	GRM219R71H333KA01#	
		0.33μF	±10%	GRM219R71H334KA88#	
			R	33000pF	±10%
	X5R			1.0μF	±10%
				±20%	GRM219R61H105MA73#
		2.2μF	±10%	GRM219R61H225KE15#	
			±20%	GRM219R61H225ME15#	

T 最大值	额定 电压	温度特 性代号	静电容量	公差	品名		
0.95mm	50Vdc	B	0.33μF	±10%	GRM219B31H334KA87#		
					±20%	GRM219B31H334MA87#	
				1.0μF	±10%	GRM219B31H105KA73#	
					±20%	GRM219B31H105MA73#	
			2.2μF		±10%	GRM219B31H225KE15#	
					±20%	GRM219B31H225ME15#	
		35Vdc		X6S	2.2μF	±10%	GRM219C8YA225KE15#
					±20%	GRM219C8YA225ME15#	
			X5R		4.7μF	±10%	GRM219R6YA475KA73# 降额
					±20%	GRM219R6YA475MA73# 降额	
				25Vdc	X7R	0.10μF	±10%
						±20%	GRM219R71E104MA01#
	0.68μF	±10%	GRM219R71E684KA88#				
		1.0μF	±10%		GRM219R71E105KA88#		
			R		68000pF	±10%	GRM219R11E683KA01#
	16Vdc				X6S	2.2μF	±10%
				±20%		GRM219C81E225ME15#	
		X5R	2.2μF	±10%		GRM219R61E225KA12#	
				±20%	GRM219R61E225MA12#		
			4.7μF	±10%	GRM219R61E475KA73#		
				±20%	GRM219R61E475MA73#		
	10μF	±10%		GRM219R61E106KA12# 降额			
			±20%	GRM219R61E106MA12# 降额			
		B	2.2μF	±10%	GRM219B31E225KA75#		
			±20%	GRM219B31E225MA75#			
	10Vdc		X7R	10μF	±10%	GRM219B31E106KA12# 降额	
				±20%	GRM219B31E106MA12# 降额		
		X7R		0.33μF	±10%	GRM219R71C334KA88#	
			2.2μF	±10%	GRM219R71C225KE15#		
					±20%	GRM219R71C225ME15#	
		6.3Vdc		R	0.68μF	±10%	GRM219R11C684KA01#
	X6S		4.7μF		±10%	GRM219C81C475KA73#	
					±20%	GRM219C81C475MA73#	
			X5R	4.7μF	±10%	GRM219R61C475KE15#	
	10μF			±10%	GRM219R61C106KA73#		
					±20%	GRM219R61C106MA73#	
		4Vdc	B	4.7μF	±10%	GRM219B31C475KE15#	
	10μF			±10%	GRM219B31C106KA73#		
					±20%	GRM219B31C106MA73#	
			10Vdc	X7R	2.2μF	±10%	GRM219R71A225KE15#
					±20%	GRM219R71A225ME15#	
	X7T				4.7μF	±10%	GRM219D71A475KE15# 降额
				±20%	GRM219D71A475ME15# 降额		
		X5R		22μF	±20%	GRM219R61A226MEA0# 降额	
	B			22μF	±20%	GRM219B31A226MEA0# 降额	
			6.3Vdc	X6S	10μF	±10%	GRM219C80J106KE39#
					±20%	GRM219C80J106ME39#	
	X5R	22μF			±20%	GRM219R60J226ME47# 降额	
B		22μF		±20%	GRM219B30J226ME47# 降额		
		4Vdc		X6S	10μF	±10%	GRM219C80G106KE19#
					±20%	GRM219C80G106ME19#	
X5R	47μF		±20%		GRM219R60G476ME44# 降额		
	2.5Vdc		X6T	47μF	±20%	GRM219D80E476ME44#	
				X7R	1000pF	±10%	GRM21AR72E102KW01#

品名 # 表示包装规格代码。

GRM 系列
GJM 系列
GMA 系列
GMD 系列
GQM 系列
GRJ 系列
GR3 系列
KRM 系列
KR3 系列
LLA 系列
LLL 系列
LLM 系列
LLR 系列
警告 / 注意事項

GRM 系列高介电常数型品名列表

(→ ■ 2.0×1.25mm)

T 最大值	额定 电压	温度特 性代号	静电容量	公差	品名	
1.0mm	250Vdc	X7R	1500pF	±10%	GRM21AR72E152KW01#	
			2200pF	±10%	GRM21AR72E222KW01#	
			3300pF	±10%	GRM21AR72E332KW01#	
			4700pF	±10%	GRM21AR72E472KW01#	
			6800pF	±10%	GRM21AR72E682KW01#	
	200Vdc	X7R	1000pF	±10%	GRM21AR72D102KW01#	
			1500pF	±10%	GRM21AR72D152KW01#	
			2200pF	±10%	GRM21AR72D222KW01#	
			3300pF	±10%	GRM21AR72D332KW01#	
			4700pF	±10%	GRM21AR72D472KW01#	
			6800pF	±10%	GRM21AR72D682KW01#	
	100Vdc	X7R	0.22μF	±10%	GRM21AR72A224KAC5#	
			0.33μF	±10%	GRM21AR72A334KAC5#	
	50Vdc	X7R	22000pF	±10%	GRM219R71H223KA17#	
				±20%	GRM219R71H223MA17#	
	35Vdc	X6S	4.7μF	±10%	GRM219C8YA475KE21# 降额	
				±20%	GRM219C8YA475ME21# 降额	
	25Vdc	X7S	4.7μF	±10%	GRM219C71E475KE21# 降额	
				±20%	GRM219C71E475ME21# 降额	
		X6S	4.7μF	±10%	GRM219C81E475KE21# 降额	
				±20%	GRM219C81E475ME21# 降额	
	16Vdc	X7S	4.7μF	±10%	GRM219C71C475KE21#	
				±20%	GRM219C71C475ME21#	
		X5R	22μF	±20%	GRM219R61C226ME15# 降额	
1.35mm	100Vdc	X7R	10000pF	±10%	GRM21BR72A103KA01#	
			15000pF	±10%	GRM21BR72A153KA01#	
			22000pF	±10%	GRM21BR72A223KA01#	
			33000pF	±10%	GRM21BR72A333KA01#	
			47000pF	±10%	GRM21BR72A473KA01#	
			68000pF	±10%	GRM21BR72A683KAC4#	
				±20%	GRM21BR72A683MAC4#	
			0.10μF	±10%	GRM21BR72A104KAC4#	
				±20%	GRM21BR72A104MAC4#	
		50Vdc	X7R	47000pF	±10%	GRM21BR71H473KA01#
				68000pF	±10%	GRM21BR71H683KA01#
				0.10μF	±10%	GRM21BR71H104KA01#
				±20%	GRM21BR71H104MA01#	
			X7R	0.15μF	±10%	GRM21BR71H154KA01#
				0.22μF	±10%	GRM21BR71H224KA01#
				0.47μF	±10%	GRM21BR71H474KA88#
			R	0.10μF	±10%	GRM21BR11H104KA01#
					±20%	GRM21BR11H104MA01#
	X5R	1.0μF	±10%	GRM21BR61H105KA12#		
	B	0.15μF	±10%	GRM21BB31H154KA88#		
				±20%	GRM21BB31H154MA88#	
		0.22μF	±10%	GRM21BB31H224KA88#		
				±20%	GRM21BB31H224MA88#	
		0.47μF	±10%	GRM21BB31H474KA87#		
				±20%	GRM21BB31H474MA87#	
	0.68μF	±10%	GRM21BB31H684KAC4#			
			±20%	GRM21BB31H684MAC4#		
	1.0μF	±10%	GRM21BB31H105KA12#			
			±20%	GRM21BB31H105MA12#		
	25Vdc	R	0.15μF	±10%	GRM21BR11E154KA01#	

T 最大值	额定 电压	温度特 性代号	静电容量	公差	品名	
1.35mm	25Vdc	R	0.15μF	±20%	GRM21BR11E154MA01#	
			X6S	4.7μF	±10%	GRM21BC81E475KA12#
					±20%	GRM21BC81E475MA12#
		X5R	4.7μF	±10%	GRM21BR61E475KA12#	
				±20%	GRM21BR61E475MA12#	
		B	2.2μF	±10%	GRM21BB31E225KA75#	
					±20%	GRM21BB31E225MA75#
			4.7μF	±10%	GRM21BB31E475KA75#	
			±20%	GRM21BB31E475MA75#		
	16Vdc	X7R	2.2μF	±10%	GRM21BR71C225KA12#	
				±20%	GRM21BR71C225MA12#	
		X5R	10μF	±10%	GRM21BR61C106KE15#	
				±20%	GRM21BR61C106ME15#	
		B	10μF	±10%	GRM21BB31C106KE15#	
					±20%	GRM21BB31C106ME15#
		1.4mm	100Vdc	X7R	0.47μF	±10%
X5R	2.2μF				±10%	GRM21BR61H225KA73#
					±20%	GRM21BR61H225MA73#
B	4.7μF			±10%	GRM21BR61H475KE51#	
				±20%	GRM21BR61H475ME51#	
25Vdc	X7R		2.2μF	±10%	GRM21BB31H225KA73#	
				±20%	GRM21BB31H225MA73#	
	X7R		1.0μF	±10%	GRM21BR71E105KA99#	
			2.2μF	±10%	GRM21BR71E225KE11#	
				±20%	GRM21BR71E225ME11#	
	R		4.7μF	±10%	GRM21BR71E475KA73# 降额	
				±20%	GRM21BR71E475MA73# 降额	
X5R	1.0μF		±10%	GRM21BR11E105KA99#		
	10μF		±10%	GRM21BR61E106KA73#		
			±20%	GRM21BR61E106MA73#		
B	10μF	±10%	GRM21BB31E106KA73#			
			±20%	GRM21BB31E106MA73#		
16Vdc	X7R	4.7μF	±10%	GRM21BR71C475KA73#		
			±20%	GRM21BR71C475MA73#		
	X6S	10μF	±10%	GRM21BC81C106KA73#		
			±20%	GRM21BC81C106MA73#		
10Vdc	X7R	4.7μF	±10%	GRM21BR71A475KA73#		
			±20%	GRM21BR71A475MA73#		
	B	10μF	±10%	GRM21BR71A106KE51#		
				±20%	GRM21BR71A106ME51#	
6.3Vdc	X7R	10μF	±10%	GRM21BR70J106KE76#		
			±20%	GRM21BR70J106ME76#		
	X6S	22μF	±20%	GRM21BC80J226ME51# 降额		
4Vdc	X7U	22μF	±20%	GRM21BE70G226ME51#		
		X6S	22μF	±20%	GRM21BC80G226ME39#	
1.45mm	250Vdc	X7R	10000pF	±10%	GRM21BR72E103KW03#	
			15000pF	±10%	GRM21BR72E153KW03#	
			22000pF	±10%	GRM21BR72E223KW03#	
	200Vdc	X7R	10000pF	±10%	GRM21BR72D103KW03#	
			15000pF	±10%	GRM21BR72D153KW03#	
			22000pF	±10%	GRM21BR72D223KW03#	

品名 # 表示包装规格代码。

GRM 系列
GJM 系列
GMA 系列
GMD 系列
GQM 系列
GRJ 系列
GR3 系列
KRM 系列
KR3 系列
LLA 系列
LLL 系列
LLM 系列
LLR 系列
警告/注意事项

GRM 系列高介电常数型品名列表

(→ ■ 2.0×1.25mm)

T 最大值	额定 电压	温度特 性代号	静电容量	公差	品名		
1.45mm	50Vdc	X7S	4.7μF	±10%	GRM21BC71H475KE11#		
				±20%	GRM21BC71H475ME11#		
			X6S	4.7μF	±10%	GRM21BC81H475KE11#	
					±20%	GRM21BC81H475ME11#	
		35Vdc	X7S	4.7μF	±10%	GRM21BC7YA475KE11#	
					±20%	GRM21BC7YA475ME11#	
				X6S	10μF	±10%	GRM21BC8YA106KE11# 降额
						±20%	GRM21BC8YA106ME11# 降额
	X5R		10μF	±10%	GRM21BR6YA106KE43# 降额		
				±20%	GRM21BR6YA106ME43# 降额		
	25Vdc		X7S	4.7μF	±10%	GRM21BC71E475KE11#	
					±20%	GRM21BC71E475ME11#	
		10μF		±10%	GRM21BC71E106KE11# 降额		
				±20%	GRM21BC71E106ME11# 降额		
		X6S	10μF	±10%	GRM21BC81E106KE11# 降额		
				±20%	GRM21BC81E106ME11# 降额		
		X5R	22μF	±20%	GRM21BR61E226ME44#		
	16Vdc	X7S	10μF	±10%	GRM21BC71C106KE11#		
				±20%	GRM21BC71C106ME11#		
		X6S	22μF	±20%	GRM21BC81C226ME44# 降额		
		X5R	22μF	±20%	GRM21BR61C226ME44#		
10Vdc	X7T	22μF	±20%	GRM21BD71A226ME44# 降额			
	X6S	22μF	±20%	GRM21BC81A226ME44#			
	X5R	22μF	±20%	GRM21BR61A226ME44#			
			47μF	±20%	GRM21BR61A476ME15# 降额		
6.3Vdc	X7T	22μF	±20%	GRM21BD70J226ME44#			
	X5R	47μF	±20%	GRM21BR60J476ME15# 降额			
	B	47μF	±20%	GRM21BB30J476ME15# 降额			
4Vdc	X6S	47μF	±20%	GRM21BC80G476ME15# 降额			
X5R	47μF	±20%	GRM21BR60G476ME15#				
		B	47μF	±20%	GRM21BB30G476ME15#		

■ 3.2×1.6mm

T 最大值	额定 电压	温度特 性代号	静电容量	公差	品名	
0.95mm	35Vdc	X5R	10μF	±10%	GRM319R6YA106KA12# 降额	
				±20%	GRM319R6YA106MA12# 降额	
			R	0.33μF	±10%	GRM319R11E334KA01#
		16Vdc	X5R	10μF	±10%	GRM319R61C106KE15#
					±20%	GRM319R61C106ME15#
				22μF	±20%	GRM319R61C226ME15# 降额
	B		10μF	±10%	GRM319B31C106KE15#	
				±20%	GRM319B31C106ME15#	
	22μF		±20%	GRM319B31C226ME15# 降额		
	10Vdc	X5R	22μF	±20%	GRM319R61A226ME15#	
		B	22μF	±20%	GRM319B31A226ME15#	
		6.3Vdc	X6S	22μF	±20%	GRM319C80J226ME15#
	X5R	22μF	±20%	GRM319R60J226ME15#		
			B	22μF	±20%	GRM319B30J226ME15#
	1.0mm	630Vdc	X7R	1000pF	±10%	GRM31AR72J102KW01#
				1500pF	±10%	GRM31AR72J152KW01#
				2200pF	±10%	GRM31AR72J222KW01#
				3300pF	±10%	GRM31AR72J332KW01#

T 最大值	额定 电压	温度特 性代号	静电容量	公差	品名			
1.0mm	630Vdc	X7R	4700pF	±10%	GRM31AR72J472KW01#			
			6800pF	±10%	GRM31AR72J682KW01#			
			10000pF	±10%	GRM31AR72J103KW01#			
			1.25mm	1000Vdc	X7R	470pF	±10%	GRM31BR73A471KW01#
						680pF	±10%	GRM31BR73A681KW01#
						1000pF	±10%	GRM31BR73A102KW01#
	1500pF	±10%	GRM31BR73A152KW01#					
		2200pF	±10%	GRM31BR73A222KW01#				
		3300pF	±10%	GRM31BR73A332KW01#				
	4700pF	±10%	GRM31BR73A472KW01#					
		630Vdc	X7R	6800pF	±10%	GRM31BR72J682KW01#		
				15000pF	±10%	GRM31BR72E153KW01#		
	22000pF			±10%	GRM31BR72E223KW01#			
	68000pF	±10%	GRM31BR72E683KW01#					
	200Vdc	X7R	15000pF	±10%	GRM31BR72D153KW01#			
			22000pF	±10%	GRM31BR72D223KW01#			
			68000pF	±10%	GRM31BR72D683KW01#			
		50Vdc	X7R	0.47μF	±10%	GRM31MR71H474KA01#		
				0.68μF	±10%	GRM31MR71H684KA88#		
				1.0μF	±10%	GRM31MR71H105KA88#		
	B	1.0μF	±10%	GRM31MB31H105KA87#				
	25Vdc	X5R	10μF	±20%	GRM31MR61E106MA12#			
	1.3mm	100Vdc	X7R	0.47μF	±10%	GRM31MR72A474KA35#		
				±20%	GRM31MR72A474MA35#			
0.68μF				±10%	GRM31MR72A684KA35#			
1.8mm				1000Vdc	X7R	6800pF	±10%	GRM31CR73A682KW03#
						10000pF	±10%	GRM31CR73A103KW03#
						630Vdc	X7R	15000pF
22000pF	±10%	GRM31CR72J223KW03#						
250Vdc	X7R	33000pF	±10%	GRM31CR72E333KW03#				
		47000pF	±10%	GRM31CR72E473KW03#				
		0.10μF	±10%	GRM31CR72E104KW03#				
	200Vdc	X7R	33000pF	±10%	GRM31CR72D333KW03#			
			47000pF	±10%	GRM31CR72D473KW03#			
			0.10μF	±10%	GRM31CR72D104KW03#			
100Vdc	X7R	1.0μF	±10%	GRM31CR72A105KA01#				
50Vdc	X7R	2.2μF	±10%	GRM31CR71H225KA88#				
			±20%	GRM31CR71H475MA12#				
		4.7μF	±10%	GRM31CR71H475KA12#				
			±20%	GRM31CR71H475MA12#				
		X5R	10μF	±10%	GRM31CR61H106KA12#			
				±20%	GRM31CR61H106MA12#			
	B	2.2μF	±10%	GRM31CB31H225KA87#				
			±20%	GRM31CB31H225MA87#				
	4.7μF	±10%	GRM31CB31H475KA12#					
		±20%	GRM31CB31H475MA12#					
	10μF	±10%	GRM31CB31H106KA12#					
		±20%	GRM31CB31H106MA12#					
25Vdc	X7R	4.7μF	±10%	GRM31CR71E475KA88#				
			±10%	GRM31CR71E106KA12#				
		±20%	GRM31CR71E106MA12#					
	X5R	22μF	±20%	GRM31CR61E226ME15#				
		B	10μF	±10%	GRM31CB31E106KA75#			
22μF	±20%	GRM31CB31E226ME15#						
16Vdc	X7R	4.7μF	±20%	GRM31CR71C475MA01#				

品名 # 表示包装规格代码。

GRM 系列
GJM 系列
GMA 系列
GMD 系列
GQM 系列
GRJ 系列
GR3 系列
KRM 系列
KR3 系列
LLA 系列
LLL 系列
LLM 系列
LLR 系列
警告 / 注意 事项

GRM 系列高介电常数型品名列表

(→ ■ 3.2×1.6mm)

T 最大值	额定 电压	温度特 性代号	静电容量	公差	品名
1.8mm	16Vdc	X6S	22μF	±20%	GRM31CC81C226ME15#
		X5R	22μF	±20%	GRM31CR61C226ME15#
		B	22μF	±20%	GRM31CB31C226ME15#
	10Vdc	X7R	22μF	±20%	GRM31CR71A226ME15#
		X5R	47μF	±20%	GRM31CR61A476ME15#
		B	47μF	±20%	GRM31CB31A476ME15#
	6.3Vdc	X7R	22μF	±20%	GRM31CR70J226ME19#
		X7U	47μF	±20%	GRM31CE70J476ME15#
		X6S	47μF	±20%	GRM31CC80J476ME18#
		X5R	47μF	±20%	GRM31CR60J476ME19#
		B	47μF	±20%	GRM31CB30J476ME18#
	4Vdc	X7U	47μF	±20%	GRM31CE70G476ME15#
		X6S	47μF	±20%	GRM31CC80G476ME19#
	1.9mm	100Vdc	X7R	2.2μF	±10%
±20%				GRM31CR72A225MA73#	
25Vdc		X6S	22μF	±20%	GRM31CC81E226ME11#
			16Vdc	X7S	22μF
6.3Vdc		X6T	100μF	±20%	GRM31CD80J107ME39#
			X5R	100μF	±20%
4Vdc		X7U	100μF	±20%	GRM31CE70G107ME39#
			X6T	100μF	±20%
		X5R	100μF	±20%	GRM31CR60G107ME39#
			220μF	±20%	GRM31CR60G227ME11#

■ 3.2×2.5mm

T 最大值	额定 电压	温度特 性代号	静电容量	公差	品名
1.5mm	1000Vdc	X7R	6800pF	±10%	GRM32QR73A682KW01#
			10000pF	±10%	GRM32QR73A103KW01#
	630Vdc	X7R	22000pF	±10%	GRM32QR72J223KW01#
			250Vdc	X7R	68000pF
	200Vdc	X7R	0.15μF	±10%	GRM32QR72E154KW01#
			68000pF	±10%	GRM32QR72D683KW01#
0.15μF	±10%	GRM32QR72D154KW01#			
1.8mm	100Vdc	X7R	1.0μF	±10%	GRM32CR72A105KA35#
			±20%	GRM32CR72A105MA35#	
2.0mm	1000Vdc	X7R	15000pF	±10%	GRM32DR73A153KW01#
			22000pF	±10%	GRM32DR73A223KW01#
	630Vdc	X7R	33000pF	±10%	GRM32DR72J333KW01#
			47000pF	±10%	GRM32DR72J473KW01#
			250Vdc	X7R	0.10μF
	200Vdc	X7R	0.22μF	±10%	GRM32DR72E224KW01#
			0.10μF	±10%	GRM32DR72D104KW01#
	0.22μF	±10%	GRM32DR72D224KW01#		
2.2mm	25Vdc	X7R	10μF	±10%	GRM32DR71E106KA12#
2.7mm	100Vdc	X7R	2.2μF	±10%	GRM32ER72A225KA35#
			±20%	GRM32ER72A225MA35#	
	80Vdc	X7R	4.7μF	±10%	GRM32ER71K475KE14#
			±20%	GRM32ER71K475ME14#	
	63Vdc	X7R	10μF	±10%	GRM32ER71J106KA12#
			±20%	GRM32ER71J106MA12#	
50Vdc	X7R	4.7μF	±10%	GRM32ER71H475KA88#	
		10μF	±10%	GRM32ER71H106KA12#	

T 最大值	额定 电压	温度特 性代号	静电容量	公差	品名
2.7mm	50Vdc	X7R	10μF	±20%	GRM32ER71H106MA12#
			X5R	10μF	±10%
		B	±20%	GRM32ER61H106MA12#	
			10μF	±10%	GRM32EB31H106KA12#
		±20%	GRM32EB31H106MA12#		
		35Vdc	X7R	10μF	±10%
	±20%			GRM32ER7YA106MA12#	
	X5R		10μF	±10%	GRM32ER6YA106KA12#
			±20%	GRM32ER6YA106MA12#	
	B		10μF	±10%	GRM32EB3YA106KA12#
			±20%	GRM32EB3YA106MA12#	
	25Vdc	X7R	22μF	±20%	GRM32ER71E226ME15#
			X5R	22μF	±20%
		B	22μF	±20%	GRM32EB31E226ME15#
	16Vdc	X7R	22μF	±20%	GRM32ER71C226ME15#
			X6S	47μF	±20%
		X5R	47μF	±20%	GRM32ER61C476ME15#
			B	47μF	±20%
10Vdc	X7R	47μF	±20%	GRM32ER71A476ME15#	
		X5R	47μF	±20%	GRM32ER61A476ME20#
	B	100μF	±20%	GRM32ER61A107ME20#	
		47μF	±20%	GRM32EB31A476ME20#	
6.3Vdc	X7R	47μF	±20%	GRM32ER70J476ME20#	
		X7U	100μF	±20%	GRM32EE70J107ME15#
	X5R	100μF	±20%	GRM32ER60J107ME20#	
B	100μF	±20%	GRM32EB30J107ME16#		
4Vdc	X7U	100μF	±20%	GRM32EE70G107ME19#	

■ 4.5×3.2mm

T 最大值	额定 电压	温度特 性代号	静电容量	公差	品名
1.5mm	630Vdc	X7R	68000pF	±10%	GRM43QR72J683KW01#
	250Vdc	X7R	0.15μF	±10%	GRM43QR72E154KW01#
	200Vdc	X7R	0.15μF	±10%	GRM43QR72D154KW01#
2.0mm	1000Vdc	X7R	33000pF	±10%	GRM43DR73A333KW01#
			47000pF	±10%	GRM43DR73A473KW01#
	630Vdc	X7R	0.10μF	±10%	GRM43DR72J104KW01#
			250Vdc	X7R	0.22μF
	200Vdc	X7R	0.33μF	±10%	GRM43DR72E334KW01#
			0.47μF	±10%	GRM43DR72E474KW01#
0.22μF	±10%	GRM43DR72D224KW01#			
0.33μF	±10%	GRM43DR72D334KW01#			
0.47μF	±10%	GRM43DR72D474KW01#			

■ 5.7×5.0mm

T 最大值	额定 电压	温度特 性代号	静电容量	公差	品名
2.0mm	1000Vdc	X7R	68000pF	±10%	GRM55DR73A683KW01#
			0.10μF	±10%	GRM55DR73A104KW01#
	630Vdc	X7R	0.15μF	±10%	GRM55DR72J154KW01#
			0.22μF	±10%	GRM55DR72J224KW01#
	250Vdc	X7R	0.33μF	±10%	GRM55DR72E334KW01#

品名 # 表示包装规格代码。

GRM 系列
GJM 系列
GMA 系列
GMD 系列
GQM 系列
GRJ 系列
GR3 系列
KRM 系列
KR3 系列
LLA 系列
LLL 系列
LLM 系列
LLR 系列
警告/注意事项

GRM 系列

GJM 系列

GMA 系列

GMD 系列

GQM 系列

GRJ 系列

GR3 系列

KRM 系列

KR3 系列

LLA 系列

LLL 系列

LLM 系列

LLR 系列

警告 / 注意事项

GRM 系列高介电常数型品名列表

(→ ■ 5.7×5.0mm)

T 最大值	额定 电压	温度特 性代号	静电容量	公差	品名
2.0mm	250Vdc	X7R	0.47μF	±10%	GRM55DR72E474KW01#
			0.68μF	±10%	GRM55DR72E684KW01#
			1.0μF	±10%	GRM55DR72E105KW01#
	200Vdc	X7R	0.33μF	±10%	GRM55DR72D334KW01#
			0.47μF	±10%	GRM55DR72D474KW01#
			0.68μF	±10%	GRM55DR72D684KW01#
			1.0μF	±10%	GRM55DR72D105KW01#

www.tocosc.com

高频型高Q型1005 (单位: mm) / 0402 (单位: 英寸) 最大尺寸

GJM 系列



本产品凭借高频低功耗值和低ESR提高了高频特性，极大地降低了功耗。

特点

① 非常适合用于移动通讯设备及相关模块的温度补偿。

本产品非常适合用于高频电路的温度补偿，例如设备的工作特性受电容波动严重影响的谐振电路、调谐电路及阻抗匹配电路。本产品非常适合用于高频电路的温度补偿，例如设备的工作特性受电容波动严重影响的谐振电路、调谐电路及阻抗匹配电路。

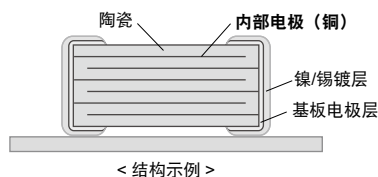

② 在VHF、UHF 和微波频段时高Q和低ESR。

通过使用陶瓷材料作为在高频下能实现超低损耗的介电材料，以及使用金属基板电极作为内部电极，在高频下获得了高Q值和低ESR。

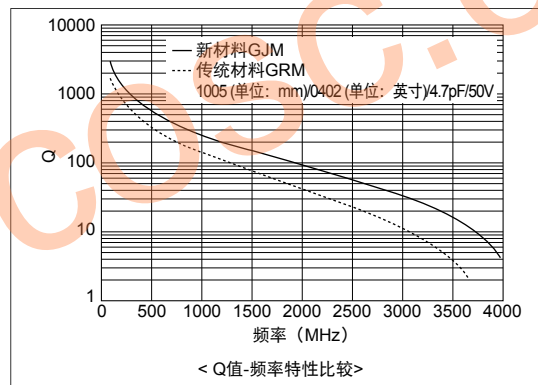
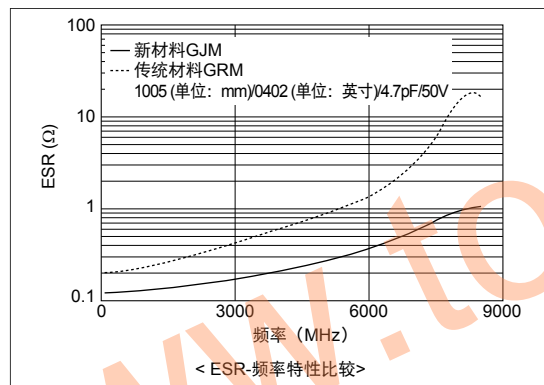

③ 可用于对公差要求严格的应用。

除标准公差外，本产品的可允许公差范围还符合以下严格的公差要求。

静电容量范围	标准静电容量公差 (静电容量公差符号)	窄静电容量公差 (静电容量公差符号)
≤0.9pF	±0.1pF (B)	±0.05pF (W)
1.0 to 5.0pF	±0.25pF (C)	±0.05pF (W), ±0.1pF (B)
5.1 to 9.9pF	±0.5pF (D)	±0.05pF (W), ±0.1pF (B), ±0.25pF (C)
≥10pF	±5% (J)	±2% (G)

规格

尺寸	0.4×0.2mm 到 1.0×0.5mm
额定电压	DC6.3V 到 50V
静电容量	0.1pF 到 47pF
主要应用	小型通讯设备，比如手机和高速通讯模块

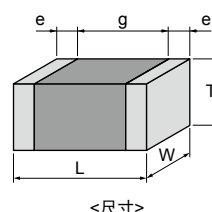

本目录仅列出了部分产品系列。
 详情请参阅村田网站中的电容器检索工具。

GRM 系列
GJM 系列
GMA 系列
GMD 系列
GQM 系列
GRJ 系列
GR3 系列
KRM 系列
KR3 系列
LLA 系列
LLL 系列
LLM 系列
LLR 系列
警告/注意事项

GJM 系列温度补偿型 **高Q** 品名列表

■ 0.4×0.2mm **Ultra-compact**

T 最大值	额定 电压	温度特 性代号	静电容量	公差	品名
0.22mm	25Vdc	C0G	0.20pF	±0.05pF	GJM0225C1E2R20WB01#
				±0.1pF	GJM0225C1E2R20BB01#
			0.30pF	±0.05pF	GJM0225C1E2R30WB01#
				±0.1pF	GJM0225C1E2R30BB01#
			0.40pF	±0.05pF	GJM0225C1E2R40WB01#
				±0.1pF	GJM0225C1E2R40BB01#
			0.50pF	±0.05pF	GJM0225C1E2R50WB01#
				±0.1pF	GJM0225C1E2R50BB01#
			0.60pF	±0.05pF	GJM0225C1E2R60WB01#
				±0.1pF	GJM0225C1E2R60BB01#
			0.70pF	±0.05pF	GJM0225C1E2R70WB01#
				±0.1pF	GJM0225C1E2R70BB01#
			0.80pF	±0.05pF	GJM0225C1E2R80WB01#
				±0.1pF	GJM0225C1E2R80BB01#
			0.90pF	±0.05pF	GJM0225C1E2R90WB01#
				±0.1pF	GJM0225C1E2R90BB01#
			1.0pF	±0.05pF	GJM0225C1E1R0WB01#
				±0.1pF	GJM0225C1E1R0BB01#
				±0.25pF	GJM0225C1E1R0CB01#
			1.1pF	±0.05pF	GJM0225C1E1R1WB01#
				±0.1pF	GJM0225C1E1R1BB01#
				±0.25pF	GJM0225C1E1R1CB01#
			1.2pF	±0.05pF	GJM0225C1E1R2WB01#
				±0.1pF	GJM0225C1E1R2BB01#
				±0.25pF	GJM0225C1E1R2CB01#
			1.3pF	±0.05pF	GJM0225C1E1R3WB01#
				±0.1pF	GJM0225C1E1R3BB01#
				±0.25pF	GJM0225C1E1R3CB01#
			1.4pF	±0.05pF	GJM0225C1E1R4WB01#
				±0.1pF	GJM0225C1E1R4BB01#
				±0.25pF	GJM0225C1E1R4CB01#
			1.5pF	±0.05pF	GJM0225C1E1R5WB01#
				±0.1pF	GJM0225C1E1R5BB01#
				±0.25pF	GJM0225C1E1R5CB01#
			1.6pF	±0.05pF	GJM0225C1E1R6WB01#
				±0.1pF	GJM0225C1E1R6BB01#
				±0.25pF	GJM0225C1E1R6CB01#
			1.7pF	±0.05pF	GJM0225C1E1R7WB01#
				±0.1pF	GJM0225C1E1R7BB01#
				±0.25pF	GJM0225C1E1R7CB01#
			1.8pF	±0.05pF	GJM0225C1E1R8WB01#
				±0.1pF	GJM0225C1E1R8BB01#
				±0.25pF	GJM0225C1E1R8CB01#
			1.9pF	±0.05pF	GJM0225C1E1R9WB01#
				±0.1pF	GJM0225C1E1R9BB01#
				±0.25pF	GJM0225C1E1R9CB01#
			2.0pF	±0.05pF	GJM0225C1E2R0WB01#
				±0.1pF	GJM0225C1E2R0BB01#
±0.25pF	GJM0225C1E2R0CB01#				
2.1pF	±0.05pF	GJM0225C1E2R1WB01#			
	±0.1pF	GJM0225C1E2R1BB01#			
	±0.25pF	GJM0225C1E2R1CB01#			

T 最大值	额定 电压	温度特 性代号	静电容量	公差	品名
0.22mm	25Vdc	C0G	2.2pF	±0.05pF	GJM0225C1E2R2WB01#
				±0.1pF	GJM0225C1E2R2BB01#
				±0.25pF	GJM0225C1E2R2CB01#
			2.3pF	±0.05pF	GJM0225C1E2R3WB01#
				±0.1pF	GJM0225C1E2R3BB01#
				±0.25pF	GJM0225C1E2R3CB01#
			2.4pF	±0.05pF	GJM0225C1E2R4WB01#
				±0.1pF	GJM0225C1E2R4BB01#
				±0.25pF	GJM0225C1E2R4CB01#
			2.5pF	±0.05pF	GJM0225C1E2R5WB01#
				±0.1pF	GJM0225C1E2R5BB01#
				±0.25pF	GJM0225C1E2R5CB01#
			2.6pF	±0.05pF	GJM0225C1E2R6WB01#
				±0.1pF	GJM0225C1E2R6BB01#
				±0.25pF	GJM0225C1E2R6CB01#
			2.7pF	±0.05pF	GJM0225C1E2R7WB01#
				±0.1pF	GJM0225C1E2R7BB01#
				±0.25pF	GJM0225C1E2R7CB01#
			2.8pF	±0.05pF	GJM0225C1E2R8WB01#
				±0.1pF	GJM0225C1E2R8BB01#
				±0.25pF	GJM0225C1E2R8CB01#
			2.9pF	±0.05pF	GJM0225C1E2R9WB01#
				±0.1pF	GJM0225C1E2R9BB01#
				±0.25pF	GJM0225C1E2R9CB01#
			3.0pF	±0.05pF	GJM0225C1E3R0WB01#
				±0.1pF	GJM0225C1E3R0BB01#
				±0.25pF	GJM0225C1E3R0CB01#
			3.1pF	±0.05pF	GJM0225C1E3R1WB01#
				±0.1pF	GJM0225C1E3R1BB01#
				±0.25pF	GJM0225C1E3R1CB01#
			3.2pF	±0.05pF	GJM0225C1E3R2WB01#
				±0.1pF	GJM0225C1E3R2BB01#
				±0.25pF	GJM0225C1E3R2CB01#
			3.3pF	±0.05pF	GJM0225C1E3R3WB01#
				±0.1pF	GJM0225C1E3R3BB01#
				±0.25pF	GJM0225C1E3R3CB01#
			3.4pF	±0.05pF	GJM0225C1E3R4WB01#
				±0.1pF	GJM0225C1E3R4BB01#
				±0.25pF	GJM0225C1E3R4CB01#
			3.5pF	±0.05pF	GJM0225C1E3R5WB01#
				±0.1pF	GJM0225C1E3R5BB01#
				±0.25pF	GJM0225C1E3R5CB01#
			3.6pF	±0.05pF	GJM0225C1E3R6WB01#
				±0.1pF	GJM0225C1E3R6BB01#
				±0.25pF	GJM0225C1E3R6CB01#
			3.7pF	±0.05pF	GJM0225C1E3R7WB01#
				±0.1pF	GJM0225C1E3R7BB01#
				±0.25pF	GJM0225C1E3R7CB01#
3.8pF	±0.05pF	GJM0225C1E3R8WB01#			
	±0.1pF	GJM0225C1E3R8BB01#			
	±0.25pF	GJM0225C1E3R8CB01#			
3.9pF	±0.05pF	GJM0225C1E3R9WB01#			
	±0.1pF	GJM0225C1E3R9BB01#			
	±0.25pF	GJM0225C1E3R9CB01#			

品名 # 表示包装规格代码。

GRM 系列
GJM 系列
GMA 系列
GMD 系列
GQM 系列
GRJ 系列
GR3 系列
KRM 系列
KR3 系列
LLA 系列
LLL 系列
LLM 系列
LLR 系列
警告 / 注意事項

GJM 系列温度补偿型 **高Q** 品名列表

(→ ■ 0.4×0.2mm)

T 最大值	额定 电压	温度特 性代号	静电容量	公差	品名
0.22mm	25Vdc	C0G	4.0pF	±0.05pF	GJM0225C1E4R0WB01#
				±0.1pF	GJM0225C1E4R0BB01#
				±0.25pF	GJM0225C1E4R0CB01#
			4.1pF	±0.05pF	GJM0225C1E4R1WB01#
				±0.1pF	GJM0225C1E4R1BB01#
				±0.25pF	GJM0225C1E4R1CB01#
			4.2pF	±0.05pF	GJM0225C1E4R2WB01#
				±0.1pF	GJM0225C1E4R2BB01#
				±0.25pF	GJM0225C1E4R2CB01#
			4.3pF	±0.05pF	GJM0225C1E4R3WB01#
				±0.1pF	GJM0225C1E4R3BB01#
				±0.25pF	GJM0225C1E4R3CB01#
			4.4pF	±0.05pF	GJM0225C1E4R4WB01#
				±0.1pF	GJM0225C1E4R4BB01#
				±0.25pF	GJM0225C1E4R4CB01#
			4.5pF	±0.05pF	GJM0225C1E4R5WB01#
				±0.1pF	GJM0225C1E4R5BB01#
				±0.25pF	GJM0225C1E4R5CB01#
			4.6pF	±0.05pF	GJM0225C1E4R6WB01#
				±0.1pF	GJM0225C1E4R6BB01#
				±0.25pF	GJM0225C1E4R6CB01#
			4.7pF	±0.05pF	GJM0225C1E4R7WB01#
				±0.1pF	GJM0225C1E4R7BB01#
				±0.25pF	GJM0225C1E4R7CB01#
			4.8pF	±0.05pF	GJM0225C1E4R8WB01#
				±0.1pF	GJM0225C1E4R8BB01#
				±0.25pF	GJM0225C1E4R8CB01#
			4.9pF	±0.05pF	GJM0225C1E4R9WB01#
				±0.1pF	GJM0225C1E4R9BB01#
				±0.25pF	GJM0225C1E4R9CB01#
			5.0pF	±0.05pF	GJM0225C1E5R0WB01#
				±0.1pF	GJM0225C1E5R0BB01#
				±0.25pF	GJM0225C1E5R0CB01#
			5.1pF	±0.05pF	GJM0225C1E5R1WB01#
				±0.1pF	GJM0225C1E5R1BB01#
				±0.25pF	GJM0225C1E5R1CB01#
				±0.5pF	GJM0225C1E5R1DB01#
			5.2pF	±0.05pF	GJM0225C1E5R2WB01#
				±0.1pF	GJM0225C1E5R2BB01#
				±0.25pF	GJM0225C1E5R2CB01#
				±0.5pF	GJM0225C1E5R2DB01#
			5.3pF	±0.05pF	GJM0225C1E5R3WB01#
				±0.1pF	GJM0225C1E5R3BB01#
				±0.25pF	GJM0225C1E5R3CB01#
				±0.5pF	GJM0225C1E5R3DB01#
			5.4pF	±0.05pF	GJM0225C1E5R4WB01#
				±0.1pF	GJM0225C1E5R4BB01#
				±0.25pF	GJM0225C1E5R4CB01#
				±0.5pF	GJM0225C1E5R4DB01#
			5.5pF	±0.05pF	GJM0225C1E5R5WB01#
				±0.1pF	GJM0225C1E5R5BB01#
				±0.25pF	GJM0225C1E5R5CB01#
				±0.5pF	GJM0225C1E5R5DB01#
			5.6pF	±0.05pF	GJM0225C1E5R6WB01#

T 最大值	额定 电压	温度特 性代号	静电容量	公差	品名
0.22mm	25Vdc	C0G	5.6pF	±0.1pF	GJM0225C1E5R6BB01#
				±0.25pF	GJM0225C1E5R6CB01#
				±0.5pF	GJM0225C1E5R6DB01#
			5.7pF	±0.05pF	GJM0225C1E5R7WB01#
				±0.1pF	GJM0225C1E5R7BB01#
				±0.25pF	GJM0225C1E5R7CB01#
			5.8pF	±0.05pF	GJM0225C1E5R8WB01#
				±0.1pF	GJM0225C1E5R8BB01#
				±0.25pF	GJM0225C1E5R8CB01#
			5.9pF	±0.05pF	GJM0225C1E5R9WB01#
				±0.1pF	GJM0225C1E5R9BB01#
				±0.25pF	GJM0225C1E5R9CB01#
			6.0pF	±0.05pF	GJM0225C1E6R0WB01#
				±0.1pF	GJM0225C1E6R0BB01#
				±0.25pF	GJM0225C1E6R0CB01#
			6.1pF	±0.05pF	GJM0225C1E6R1WB01#
				±0.1pF	GJM0225C1E6R1BB01#
				±0.25pF	GJM0225C1E6R1CB01#
			6.2pF	±0.05pF	GJM0225C1E6R2WB01#
				±0.1pF	GJM0225C1E6R2BB01#
				±0.25pF	GJM0225C1E6R2CB01#
			6.3pF	±0.05pF	GJM0225C1E6R3WB01#
				±0.1pF	GJM0225C1E6R3BB01#
				±0.25pF	GJM0225C1E6R3CB01#
			6.4pF	±0.05pF	GJM0225C1E6R4WB01#
				±0.1pF	GJM0225C1E6R4BB01#
				±0.25pF	GJM0225C1E6R4CB01#
			6.5pF	±0.05pF	GJM0225C1E6R5WB01#
				±0.1pF	GJM0225C1E6R5BB01#
				±0.25pF	GJM0225C1E6R5CB01#
			6.6pF	±0.05pF	GJM0225C1E6R6WB01#
				±0.1pF	GJM0225C1E6R6BB01#
				±0.25pF	GJM0225C1E6R6CB01#
			6.7pF	±0.05pF	GJM0225C1E6R7WB01#
				±0.1pF	GJM0225C1E6R7BB01#
				±0.25pF	GJM0225C1E6R7CB01#
			6.8pF	±0.05pF	GJM0225C1E6R8WB01#
				±0.1pF	GJM0225C1E6R8BB01#
				±0.25pF	GJM0225C1E6R8CB01#
			6.9pF	±0.05pF	GJM0225C1E6R9WB01#
				±0.1pF	GJM0225C1E6R9BB01#
				±0.25pF	GJM0225C1E6R9CB01#

品名 # 表示包装规格代码。

GRM 系列
GJM 系列
GMA 系列
GMD 系列
GQM 系列
GRJ 系列
GR3 系列
KRM 系列
KR3 系列
LLA 系列
LLL 系列
LLM 系列
LLR 系列
警告/注意事项

GJM 系列温度补偿型 **高Q** 品名列表

(→ ■ 0.4×0.2mm)

T 最大值	额定 电压	温度特 性代号	静电容量	公差	品名	
0.22mm	25Vdc	C0G	6.9pF	±0.5pF	GJM0225C1E6R9DB01#	
				±0.05pF	GJM0225C1E7R0WB01#	
					±0.1pF	GJM0225C1E7R0BB01#
			±0.25pF		GJM0225C1E7R0CB01#	
			±0.5pF	GJM0225C1E7R0DB01#		
				7.1pF	±0.05pF	GJM0225C1E7R1WB01#
					±0.1pF	GJM0225C1E7R1BB01#
			±0.25pF		GJM0225C1E7R1CB01#	
			±0.5pF	GJM0225C1E7R1DB01#		
				7.2pF	±0.05pF	GJM0225C1E7R2WB01#
					±0.1pF	GJM0225C1E7R2BB01#
			±0.25pF		GJM0225C1E7R2CB01#	
			±0.5pF	GJM0225C1E7R2DB01#		
				7.3pF	±0.05pF	GJM0225C1E7R3WB01#
					±0.1pF	GJM0225C1E7R3BB01#
			±0.25pF		GJM0225C1E7R3CB01#	
			±0.5pF	GJM0225C1E7R3DB01#		
				7.4pF	±0.05pF	GJM0225C1E7R4WB01#
					±0.1pF	GJM0225C1E7R4BB01#
			±0.25pF		GJM0225C1E7R4CB01#	
			±0.5pF	GJM0225C1E7R4DB01#		
				7.5pF	±0.05pF	GJM0225C1E7R5WB01#
					±0.1pF	GJM0225C1E7R5BB01#
			±0.25pF		GJM0225C1E7R5CB01#	
			±0.5pF	GJM0225C1E7R5DB01#		
				7.6pF	±0.05pF	GJM0225C1E7R6WB01#
					±0.1pF	GJM0225C1E7R6BB01#
			±0.25pF		GJM0225C1E7R6CB01#	
			±0.5pF	GJM0225C1E7R6DB01#		
				7.7pF	±0.05pF	GJM0225C1E7R7WB01#
					±0.1pF	GJM0225C1E7R7BB01#
			±0.25pF		GJM0225C1E7R7CB01#	
			±0.5pF	GJM0225C1E7R7DB01#		
				7.8pF	±0.05pF	GJM0225C1E7R8WB01#
					±0.1pF	GJM0225C1E7R8BB01#
			±0.25pF		GJM0225C1E7R8CB01#	
			±0.5pF	GJM0225C1E7R8DB01#		
				7.9pF	±0.05pF	GJM0225C1E7R9WB01#
					±0.1pF	GJM0225C1E7R9BB01#
			±0.25pF		GJM0225C1E7R9CB01#	
			±0.5pF	GJM0225C1E7R9DB01#		
				8.0pF	±0.05pF	GJM0225C1E8R0WB01#
					±0.1pF	GJM0225C1E8R0BB01#
			±0.25pF		GJM0225C1E8R0CB01#	
			±0.5pF	GJM0225C1E8R0DB01#		
				8.1pF	±0.05pF	GJM0225C1E8R1WB01#
					±0.1pF	GJM0225C1E8R1BB01#
			±0.25pF		GJM0225C1E8R1CB01#	
			±0.5pF	GJM0225C1E8R1DB01#		
				8.2pF	±0.05pF	GJM0225C1E8R2WB01#
					±0.1pF	GJM0225C1E8R2BB01#
			±0.25pF		GJM0225C1E8R2CB01#	
			±0.5pF	GJM0225C1E8R2DB01#		
				8.3pF	±0.05pF	GJM0225C1E8R3WB01#

T 最大值	额定 电压	温度特 性代号	静电容量	公差	品名	
0.22mm	25Vdc	C0G	8.3pF	±0.1pF	GJM0225C1E8R3BB01#	
				±0.25pF	GJM0225C1E8R3CB01#	
				±0.5pF	GJM0225C1E8R3DB01#	
			8.4pF	±0.05pF	GJM0225C1E8R4WB01#	
				±0.1pF	GJM0225C1E8R4BB01#	
				±0.25pF	GJM0225C1E8R4CB01#	
			±0.5pF	GJM0225C1E8R4DB01#		
				8.5pF	±0.05pF	GJM0225C1E8R5WB01#
					±0.1pF	GJM0225C1E8R5BB01#
			±0.25pF		GJM0225C1E8R5CB01#	
			±0.5pF	GJM0225C1E8R5DB01#		
				8.6pF	±0.05pF	GJM0225C1E8R6WB01#
					±0.1pF	GJM0225C1E8R6BB01#
			±0.25pF		GJM0225C1E8R6CB01#	
			±0.5pF	GJM0225C1E8R6DB01#		
				8.7pF	±0.05pF	GJM0225C1E8R7WB01#
					±0.1pF	GJM0225C1E8R7BB01#
			±0.25pF		GJM0225C1E8R7CB01#	
			±0.5pF	GJM0225C1E8R7DB01#		
				8.8pF	±0.05pF	GJM0225C1E8R8WB01#
					±0.1pF	GJM0225C1E8R8BB01#
			±0.25pF		GJM0225C1E8R8CB01#	
			±0.5pF	GJM0225C1E8R8DB01#		
				8.9pF	±0.05pF	GJM0225C1E8R9WB01#
					±0.1pF	GJM0225C1E8R9BB01#
			±0.25pF		GJM0225C1E8R9CB01#	
			±0.5pF	GJM0225C1E8R9DB01#		
				9.0pF	±0.05pF	GJM0225C1E9R0WB01#
					±0.1pF	GJM0225C1E9R0BB01#
			±0.25pF		GJM0225C1E9R0CB01#	
			±0.5pF	GJM0225C1E9R0DB01#		
				9.1pF	±0.05pF	GJM0225C1E9R1WB01#
					±0.1pF	GJM0225C1E9R1BB01#
			±0.25pF		GJM0225C1E9R1CB01#	
			±0.5pF	GJM0225C1E9R1DB01#		
				9.2pF	±0.05pF	GJM0225C1E9R2WB01#
					±0.1pF	GJM0225C1E9R2BB01#
			±0.25pF		GJM0225C1E9R2CB01#	
			±0.5pF	GJM0225C1E9R2DB01#		
				9.3pF	±0.05pF	GJM0225C1E9R3WB01#
					±0.1pF	GJM0225C1E9R3BB01#
			±0.25pF		GJM0225C1E9R3CB01#	
			±0.5pF	GJM0225C1E9R3DB01#		
				9.4pF	±0.05pF	GJM0225C1E9R4WB01#
					±0.1pF	GJM0225C1E9R4BB01#
			±0.25pF		GJM0225C1E9R4CB01#	
			±0.5pF	GJM0225C1E9R4DB01#		
				9.5pF	±0.05pF	GJM0225C1E9R5WB01#
					±0.1pF	GJM0225C1E9R5BB01#
			±0.25pF		GJM0225C1E9R5CB01#	
			±0.5pF	GJM0225C1E9R5DB01#		
				9.6pF	±0.05pF	GJM0225C1E9R6WB01#
					±0.1pF	GJM0225C1E9R6BB01#
			±0.25pF		GJM0225C1E9R6CB01#	

品名 # 表示包装规格代码。

- GRM 系列
- GJM 系列
- GMA 系列
- GMD 系列
- GQM 系列
- GRJ 系列
- GR3 系列
- KRM 系列
- KR3 系列
- LJA 系列
- LLL 系列
- LLM 系列
- LLR 系列
- 警告 / 注意事項

GJM 系列温度补偿型 **高Q** 品名列表

(→ ■ 0.4×0.2mm)

T 最大值	额定 电压	温度特 性代号	静电容量	公差	品名	
0.22mm	25Vdc	COG	9.6pF	±0.5pF	GJM0225C1E9R6DB01#	
				±0.05pF	GJM0225C1E9R7WB01#	
			9.7pF	±0.1pF	GJM0225C1E9R7BB01#	
				±0.25pF	GJM0225C1E9R7CB01#	
				±0.5pF	GJM0225C1E9R7DB01#	
			9.8pF	±0.05pF	GJM0225C1E9R8WB01#	
				±0.1pF	GJM0225C1E9R8BB01#	
				±0.25pF	GJM0225C1E9R8CB01#	
			9.9pF	±0.05pF	GJM0225C1E9R9WB01#	
				±0.1pF	GJM0225C1E9R9BB01#	
				±0.25pF	GJM0225C1E9R9CB01#	
			10pF	±2%	GJM0225C1E100GB01#	
				±5%	GJM0225C1E100JB01#	
			11pF	±2%	GJM0225C1E110GB01#	
				±5%	GJM0225C1E110JB01#	
			12pF	±2%	GJM0225C1E120GB01#	
				±5%	GJM0225C1E120JB01#	
			13pF	±2%	GJM0225C1E130GB01#	
				±5%	GJM0225C1E130JB01#	
			15pF	±2%	GJM0225C1E150GB01#	
				±5%	GJM0225C1E150JB01#	
			16pF	±2%	GJM0225C1E160GB01#	
				±5%	GJM0225C1E160JB01#	
			18pF	±2%	GJM0225C1E180GB01#	
				±5%	GJM0225C1E180JB01#	
			20pF	±2%	GJM0225C1E200GB01#	
				±5%	GJM0225C1E200JB01#	
			22pF	±2%	GJM0225C1E220GB01#	
				±5%	GJM0225C1E220JB01#	
			CK	0.20pF	±0.05pF	GJM0224C1ER20WB01#
					±0.1pF	GJM0224C1ER20BB01#
				0.30pF	±0.05pF	GJM0224C1ER30WB01#
		±0.1pF			GJM0224C1ER30BB01#	
		0.40pF		±0.05pF	GJM0224C1ER40WB01#	
				±0.1pF	GJM0224C1ER40BB01#	
		0.50pF		±0.05pF	GJM0224C1ER50WB01#	
				±0.1pF	GJM0224C1ER50BB01#	
		0.60pF		±0.05pF	GJM0224C1ER60WB01#	
				±0.1pF	GJM0224C1ER60BB01#	
		0.70pF		±0.05pF	GJM0224C1ER70WB01#	
				±0.1pF	GJM0224C1ER70BB01#	
		0.80pF		±0.05pF	GJM0224C1ER80WB01#	
				±0.1pF	GJM0224C1ER80BB01#	
		0.90pF		±0.05pF	GJM0224C1ER90WB01#	
				±0.1pF	GJM0224C1ER90BB01#	
		1.0pF		±0.05pF	GJM0224C1E1R0WB01#	
				±0.1pF	GJM0224C1E1R0BB01#	
				±0.25pF	GJM0224C1E1R0CB01#	
		1.1pF		±0.05pF	GJM0224C1E1R1WB01#	
			±0.1pF	GJM0224C1E1R1BB01#		
			±0.25pF	GJM0224C1E1R1CB01#		
		1.2pF	±0.05pF	GJM0224C1E1R2WB01#		

T 最大值	额定 电压	温度特 性代号	静电容量	公差	品名
0.22mm	25Vdc	CK	1.2pF	±0.1pF	GJM0224C1E1R2BB01#
				±0.25pF	GJM0224C1E1R2CB01#
			1.3pF	±0.05pF	GJM0224C1E1R3WB01#
				±0.1pF	GJM0224C1E1R3BB01#
				±0.25pF	GJM0224C1E1R3CB01#
			1.4pF	±0.05pF	GJM0224C1E1R4WB01#
				±0.1pF	GJM0224C1E1R4BB01#
				±0.25pF	GJM0224C1E1R4CB01#
			1.5pF	±0.05pF	GJM0224C1E1R5WB01#
				±0.1pF	GJM0224C1E1R5BB01#
				±0.25pF	GJM0224C1E1R5CB01#
			1.6pF	±0.05pF	GJM0224C1E1R6WB01#
				±0.1pF	GJM0224C1E1R6BB01#
				±0.25pF	GJM0224C1E1R6CB01#
			1.7pF	±0.05pF	GJM0224C1E1R7WB01#
				±0.1pF	GJM0224C1E1R7BB01#
				±0.25pF	GJM0224C1E1R7CB01#
			1.8pF	±0.05pF	GJM0224C1E1R8WB01#
				±0.1pF	GJM0224C1E1R8BB01#
				±0.25pF	GJM0224C1E1R8CB01#
			1.9pF	±0.05pF	GJM0224C1E1R9WB01#
				±0.1pF	GJM0224C1E1R9BB01#
			2.0pF	±0.05pF	GJM0224C1E2R0WB01#
				±0.1pF	GJM0224C1E2R0BB01#
		±0.25pF		GJM0224C1E2R0CB01#	
		2.1pF	±0.05pF	GJM0223C1E2R1WB01#	
			±0.1pF	GJM0223C1E2R1BB01#	
			±0.25pF	GJM0223C1E2R1CB01#	
		2.2pF	±0.05pF	GJM0223C1E2R2WB01#	
			±0.1pF	GJM0223C1E2R2BB01#	
			±0.25pF	GJM0223C1E2R2CB01#	
		2.3pF	±0.05pF	GJM0223C1E2R3WB01#	
			±0.1pF	GJM0223C1E2R3BB01#	
			±0.25pF	GJM0223C1E2R3CB01#	
		2.4pF	±0.05pF	GJM0223C1E2R4WB01#	
			±0.1pF	GJM0223C1E2R4BB01#	
			±0.25pF	GJM0223C1E2R4CB01#	
		2.5pF	±0.05pF	GJM0223C1E2R5WB01#	
			±0.1pF	GJM0223C1E2R5BB01#	
			±0.25pF	GJM0223C1E2R5CB01#	
		2.6pF	±0.05pF	GJM0223C1E2R6WB01#	
			±0.1pF	GJM0223C1E2R6BB01#	
			±0.25pF	GJM0223C1E2R6CB01#	
		2.7pF	±0.05pF	GJM0223C1E2R7WB01#	
			±0.1pF	GJM0223C1E2R7BB01#	
			±0.25pF	GJM0223C1E2R7CB01#	
		2.8pF	±0.05pF	GJM0223C1E2R8WB01#	
			±0.1pF	GJM0223C1E2R8BB01#	
±0.25pF	GJM0223C1E2R8CB01#				
2.9pF	±0.05pF	GJM0223C1E2R9WB01#			
	±0.1pF	GJM0223C1E2R9BB01#			
	±0.25pF	GJM0223C1E2R9CB01#			
3.0pF	±0.05pF	GJM0223C1E3R0WB01#			
CJ	25Vdc	CJ	2.1pF	±0.05pF	GJM0223C1E2R1WB01#
				±0.1pF	GJM0223C1E2R1BB01#
			2.2pF	±0.05pF	GJM0223C1E2R2WB01#
				±0.1pF	GJM0223C1E2R2BB01#
				±0.25pF	GJM0223C1E2R2CB01#
			2.3pF	±0.05pF	GJM0223C1E2R3WB01#
				±0.1pF	GJM0223C1E2R3BB01#
				±0.25pF	GJM0223C1E2R3CB01#
			2.4pF	±0.05pF	GJM0223C1E2R4WB01#
				±0.1pF	GJM0223C1E2R4BB01#
				±0.25pF	GJM0223C1E2R4CB01#
			2.5pF	±0.05pF	GJM0223C1E2R5WB01#
				±0.1pF	GJM0223C1E2R5BB01#
				±0.25pF	GJM0223C1E2R5CB01#
			2.6pF	±0.05pF	GJM0223C1E2R6WB01#
				±0.1pF	GJM0223C1E2R6BB01#
				±0.25pF	GJM0223C1E2R6CB01#
			2.7pF	±0.05pF	GJM0223C1E2R7WB01#
				±0.1pF	GJM0223C1E2R7BB01#
				±0.25pF	GJM0223C1E2R7CB01#
			2.8pF	±0.05pF	GJM0223C1E2R8WB01#
				±0.1pF	GJM0223C1E2R8BB01#
				±0.25pF	GJM0223C1E2R8CB01#
			2.9pF	±0.05pF	GJM0223C1E2R9WB01#
±0.1pF	GJM0223C1E2R9BB01#				
±0.25pF	GJM0223C1E2R9CB01#				

品名 # 表示包装规格代码。

GRM 系列
GJM 系列
GMA 系列
GMD 系列
GQM 系列
GRJ 系列
GR3 系列
KRM 系列
KR3 系列
LLA 系列
LLL 系列
LLM 系列
LLR 系列
警告/注意事项

GJM 系列温度补偿型 **高Q** 品名列表

(→ ■ 0.4×0.2mm)

T 最大值	额定 电压	温度特 性代号	静电容量	公差	品名	
0.22mm	25Vdc	CJ	3.0pF	±0.1pF	GJM0223C1E3R0BB01#	
				±0.25pF	GJM0223C1E3R0CB01#	
			3.1pF	±0.05pF	GJM0223C1E3R1WB01#	
				±0.1pF	GJM0223C1E3R1BB01#	
				±0.25pF	GJM0223C1E3R1CB01#	
				3.2pF	±0.05pF	GJM0223C1E3R2WB01#
			±0.1pF		GJM0223C1E3R2BB01#	
			±0.25pF		GJM0223C1E3R2CB01#	
			3.3pF	±0.05pF	GJM0223C1E3R3WB01#	
				±0.1pF	GJM0223C1E3R3BB01#	
				±0.25pF	GJM0223C1E3R3CB01#	
			3.4pF	±0.05pF	GJM0223C1E3R4WB01#	
				±0.1pF	GJM0223C1E3R4BB01#	
				±0.25pF	GJM0223C1E3R4CB01#	
			3.5pF	±0.05pF	GJM0223C1E3R5WB01#	
				±0.1pF	GJM0223C1E3R5BB01#	
				±0.25pF	GJM0223C1E3R5CB01#	
			3.6pF	±0.05pF	GJM0223C1E3R6WB01#	
				±0.1pF	GJM0223C1E3R6BB01#	
				±0.25pF	GJM0223C1E3R6CB01#	
			3.7pF	±0.05pF	GJM0223C1E3R7WB01#	
				±0.1pF	GJM0223C1E3R7BB01#	
				±0.25pF	GJM0223C1E3R7CB01#	
			3.8pF	±0.05pF	GJM0223C1E3R8WB01#	
				±0.1pF	GJM0223C1E3R8BB01#	
				±0.25pF	GJM0223C1E3R8CB01#	
			3.9pF	±0.05pF	GJM0223C1E3R9WB01#	
				±0.1pF	GJM0223C1E3R9BB01#	
				±0.25pF	GJM0223C1E3R9CB01#	
			CH	4.0pF	±0.05pF	GJM0222C1E4R0WB01#
					±0.1pF	GJM0222C1E4R0BB01#
					±0.25pF	GJM0222C1E4R0CB01#
				4.1pF	±0.05pF	GJM0222C1E4R1WB01#
					±0.1pF	GJM0222C1E4R1BB01#
					±0.25pF	GJM0222C1E4R1CB01#
				4.2pF	±0.05pF	GJM0222C1E4R2WB01#
		±0.1pF			GJM0222C1E4R2BB01#	
		±0.25pF			GJM0222C1E4R2CB01#	
		4.3pF		±0.05pF	GJM0222C1E4R3WB01#	
				±0.1pF	GJM0222C1E4R3BB01#	
				±0.25pF	GJM0222C1E4R3CB01#	
		4.4pF		±0.05pF	GJM0222C1E4R4WB01#	
				±0.1pF	GJM0222C1E4R4BB01#	
				±0.25pF	GJM0222C1E4R4CB01#	
		4.5pF		±0.05pF	GJM0222C1E4R5WB01#	
				±0.1pF	GJM0222C1E4R5BB01#	
				±0.25pF	GJM0222C1E4R5CB01#	
		4.6pF		±0.05pF	GJM0222C1E4R6WB01#	
±0.1pF	GJM0222C1E4R6BB01#					
±0.25pF	GJM0222C1E4R6CB01#					
4.7pF	±0.05pF	GJM0222C1E4R7WB01#				
	±0.1pF	GJM0222C1E4R7BB01#				
	±0.25pF	GJM0222C1E4R7CB01#				
4.8pF	±0.05pF	GJM0222C1E4R8WB01#				

T 最大值	额定 电压	温度特 性代号	静电容量	公差	品名
0.22mm	25Vdc	CH	4.8pF	±0.1pF	GJM0222C1E4R8BB01#
				±0.25pF	GJM0222C1E4R8CB01#
			4.9pF	±0.05pF	GJM0222C1E4R9WB01#
				±0.1pF	GJM0222C1E4R9BB01#
				±0.25pF	GJM0222C1E4R9CB01#
				5.0pF	±0.05pF
			±0.1pF		GJM0222C1E5R0BB01#
			±0.25pF		GJM0222C1E5R0CB01#
			5.1pF	±0.05pF	GJM0222C1E5R1WB01#
				±0.1pF	GJM0222C1E5R1BB01#
				±0.25pF	GJM0222C1E5R1CB01#
			5.2pF	±0.05pF	GJM0222C1E5R2WB01#
				±0.1pF	GJM0222C1E5R2BB01#
				±0.25pF	GJM0222C1E5R2CB01#
			5.3pF	±0.05pF	GJM0222C1E5R3WB01#
				±0.1pF	GJM0222C1E5R3BB01#
				±0.25pF	GJM0222C1E5R3CB01#
			5.4pF	±0.05pF	GJM0222C1E5R4WB01#
				±0.1pF	GJM0222C1E5R4BB01#
				±0.25pF	GJM0222C1E5R4CB01#
			5.5pF	±0.05pF	GJM0222C1E5R5WB01#
				±0.1pF	GJM0222C1E5R5BB01#
				±0.25pF	GJM0222C1E5R5CB01#
			5.6pF	±0.05pF	GJM0222C1E5R6WB01#
				±0.1pF	GJM0222C1E5R6BB01#
				±0.25pF	GJM0222C1E5R6CB01#
			5.7pF	±0.05pF	GJM0222C1E5R7WB01#
				±0.1pF	GJM0222C1E5R7BB01#
				±0.25pF	GJM0222C1E5R7CB01#
			5.8pF	±0.05pF	GJM0222C1E5R8WB01#
				±0.1pF	GJM0222C1E5R8BB01#
				±0.25pF	GJM0222C1E5R8CB01#
			5.9pF	±0.05pF	GJM0222C1E5R9WB01#
				±0.1pF	GJM0222C1E5R9BB01#
				±0.25pF	GJM0222C1E5R9CB01#
			6.0pF	±0.05pF	GJM0222C1E6R0WB01#
				±0.1pF	GJM0222C1E6R0BB01#
				±0.25pF	GJM0222C1E6R0CB01#
			6.1pF	±0.05pF	GJM0222C1E6R1WB01#
				±0.1pF	GJM0222C1E6R1BB01#
				±0.25pF	GJM0222C1E6R1CB01#
			6.2pF	±0.05pF	GJM0222C1E6R2WB01#
				±0.1pF	GJM0222C1E6R2BB01#

品名 # 表示包装规格代码。

- GRM 系列
- GJM 系列
- GMA 系列
- GMD 系列
- GQM 系列
- GRJ 系列
- GR3 系列
- KRM 系列
- KR3 系列
- LJA 系列
- LLL 系列
- LLM 系列
- LLR 系列
- 警告 / 注意事项

GJM 系列温度补偿型 **高Q** 品名列表

(→ ■ 0.4×0.2mm)

T 最大值	额定 电压	温度特 性代号	静电容量	公差	品名
0.22mm	25Vdc	CH	6.2pF	±0.25pF	GJM0222C1E6R2CB01#
				±0.5pF	GJM0222C1E6R2DB01#
			6.3pF	±0.05pF	GJM0222C1E6R3WB01#
				±0.1pF	GJM0222C1E6R3BB01#
				±0.25pF	GJM0222C1E6R3CB01#
				±0.5pF	GJM0222C1E6R3DB01#
			6.4pF	±0.05pF	GJM0222C1E6R4WB01#
				±0.1pF	GJM0222C1E6R4BB01#
				±0.25pF	GJM0222C1E6R4CB01#
				±0.5pF	GJM0222C1E6R4DB01#
			6.5pF	±0.05pF	GJM0222C1E6R5WB01#
				±0.1pF	GJM0222C1E6R5BB01#
				±0.25pF	GJM0222C1E6R5CB01#
				±0.5pF	GJM0222C1E6R5DB01#
			6.6pF	±0.05pF	GJM0222C1E6R6WB01#
				±0.1pF	GJM0222C1E6R6BB01#
				±0.25pF	GJM0222C1E6R6CB01#
				±0.5pF	GJM0222C1E6R6DB01#
			6.7pF	±0.05pF	GJM0222C1E6R7WB01#
				±0.1pF	GJM0222C1E6R7BB01#
				±0.25pF	GJM0222C1E6R7CB01#
				±0.5pF	GJM0222C1E6R7DB01#
			6.8pF	±0.05pF	GJM0222C1E6R8WB01#
				±0.1pF	GJM0222C1E6R8BB01#
				±0.25pF	GJM0222C1E6R8CB01#
				±0.5pF	GJM0222C1E6R8DB01#
			6.9pF	±0.05pF	GJM0222C1E6R9WB01#
				±0.1pF	GJM0222C1E6R9BB01#
				±0.25pF	GJM0222C1E6R9CB01#
				±0.5pF	GJM0222C1E6R9DB01#
			7.0pF	±0.05pF	GJM0222C1E7R0WB01#
				±0.1pF	GJM0222C1E7R0BB01#
				±0.25pF	GJM0222C1E7R0CB01#
				±0.5pF	GJM0222C1E7R0DB01#
			7.1pF	±0.05pF	GJM0222C1E7R1WB01#
				±0.1pF	GJM0222C1E7R1BB01#
				±0.25pF	GJM0222C1E7R1CB01#
				±0.5pF	GJM0222C1E7R1DB01#
			7.2pF	±0.05pF	GJM0222C1E7R2WB01#
				±0.1pF	GJM0222C1E7R2BB01#
				±0.25pF	GJM0222C1E7R2CB01#
				±0.5pF	GJM0222C1E7R2DB01#
			7.3pF	±0.05pF	GJM0222C1E7R3WB01#
				±0.1pF	GJM0222C1E7R3BB01#
				±0.25pF	GJM0222C1E7R3CB01#
				±0.5pF	GJM0222C1E7R3DB01#
			7.4pF	±0.05pF	GJM0222C1E7R4WB01#
				±0.1pF	GJM0222C1E7R4BB01#
				±0.25pF	GJM0222C1E7R4CB01#
				±0.5pF	GJM0222C1E7R4DB01#
			7.5pF	±0.05pF	GJM0222C1E7R5WB01#
				±0.1pF	GJM0222C1E7R5BB01#
				±0.25pF	GJM0222C1E7R5CB01#
				±0.5pF	GJM0222C1E7R5DB01#

T 最大值	额定 电压	温度特 性代号	静电容量	公差	品名
0.22mm	25Vdc	CH	7.6pF	±0.05pF	GJM0222C1E7R6WB01#
				±0.1pF	GJM0222C1E7R6BB01#
				±0.25pF	GJM0222C1E7R6CB01#
				±0.5pF	GJM0222C1E7R6DB01#
			7.7pF	±0.05pF	GJM0222C1E7R7WB01#
				±0.1pF	GJM0222C1E7R7BB01#
				±0.25pF	GJM0222C1E7R7CB01#
				±0.5pF	GJM0222C1E7R7DB01#
			7.8pF	±0.05pF	GJM0222C1E7R8WB01#
				±0.1pF	GJM0222C1E7R8BB01#
				±0.25pF	GJM0222C1E7R8CB01#
				±0.5pF	GJM0222C1E7R8DB01#
			7.9pF	±0.05pF	GJM0222C1E7R9WB01#
				±0.1pF	GJM0222C1E7R9BB01#
				±0.25pF	GJM0222C1E7R9CB01#
				±0.5pF	GJM0222C1E7R9DB01#
			8.0pF	±0.05pF	GJM0222C1E8R0WB01#
				±0.1pF	GJM0222C1E8R0BB01#
				±0.25pF	GJM0222C1E8R0CB01#
				±0.5pF	GJM0222C1E8R0DB01#
			8.1pF	±0.05pF	GJM0222C1E8R1WB01#
				±0.1pF	GJM0222C1E8R1BB01#
				±0.25pF	GJM0222C1E8R1CB01#
				±0.5pF	GJM0222C1E8R1DB01#
			8.2pF	±0.05pF	GJM0222C1E8R2WB01#
				±0.1pF	GJM0222C1E8R2BB01#
				±0.25pF	GJM0222C1E8R2CB01#
				±0.5pF	GJM0222C1E8R2DB01#
			8.3pF	±0.05pF	GJM0222C1E8R3WB01#
				±0.1pF	GJM0222C1E8R3BB01#
				±0.25pF	GJM0222C1E8R3CB01#
				±0.5pF	GJM0222C1E8R3DB01#
			8.4pF	±0.05pF	GJM0222C1E8R4WB01#
				±0.1pF	GJM0222C1E8R4BB01#
				±0.25pF	GJM0222C1E8R4CB01#
				±0.5pF	GJM0222C1E8R4DB01#
			8.5pF	±0.05pF	GJM0222C1E8R5WB01#
				±0.1pF	GJM0222C1E8R5BB01#
				±0.25pF	GJM0222C1E8R5CB01#
				±0.5pF	GJM0222C1E8R5DB01#
			8.6pF	±0.05pF	GJM0222C1E8R6WB01#
				±0.1pF	GJM0222C1E8R6BB01#
				±0.25pF	GJM0222C1E8R6CB01#
				±0.5pF	GJM0222C1E8R6DB01#
			8.7pF	±0.05pF	GJM0222C1E8R7WB01#
				±0.1pF	GJM0222C1E8R7BB01#
				±0.25pF	GJM0222C1E8R7CB01#
				±0.5pF	GJM0222C1E8R7DB01#
			8.8pF	±0.05pF	GJM0222C1E8R8WB01#
				±0.1pF	GJM0222C1E8R8BB01#
				±0.25pF	GJM0222C1E8R8CB01#
				±0.5pF	GJM0222C1E8R8DB01#
			8.9pF	±0.05pF	GJM0222C1E8R9WB01#
				±0.1pF	GJM0222C1E8R9BB01#

品名 # 表示包装规格代码。

GRM 系列
GJM 系列
GMA 系列
GMD 系列
GQM 系列
GRJ 系列
GR3 系列
KRM 系列
KR3 系列
LLA 系列
LLL 系列
LLM 系列
LLR 系列
警告/注意事项

GRM 系列

GJM 系列

GMA 系列

GMD 系列

GQM 系列

GRJ 系列

GR3 系列

KRM 系列

KR3 系列

LJA 系列

LLL 系列

LLM 系列

LLR 系列

警告 / 注意事項

GJM 系列温度补偿型 **高Q** 品名列表

(→ ■ 0.4×0.2mm)

T 最大值	额定 电压	温度特 性代号	静电容量	公差	品名
0.22mm	25Vdc	CH	8.9pF	±0.25pF	GJM0222C1E8R9CB01#
				±0.5pF	GJM0222C1E8R9DB01#
			9.0pF	±0.05pF	GJM0222C1E9R0WB01#
				±0.1pF	GJM0222C1E9R0BB01#
				±0.25pF	GJM0222C1E9R0CB01#
				±0.5pF	GJM0222C1E9R0DB01#
			9.1pF	±0.05pF	GJM0222C1E9R1WB01#
				±0.1pF	GJM0222C1E9R1BB01#
				±0.25pF	GJM0222C1E9R1CB01#
				±0.5pF	GJM0222C1E9R1DB01#
			9.2pF	±0.05pF	GJM0222C1E9R2WB01#
				±0.1pF	GJM0222C1E9R2BB01#
				±0.25pF	GJM0222C1E9R2CB01#
				±0.5pF	GJM0222C1E9R2DB01#
			9.3pF	±0.05pF	GJM0222C1E9R3WB01#
				±0.1pF	GJM0222C1E9R3BB01#
				±0.25pF	GJM0222C1E9R3CB01#
				±0.5pF	GJM0222C1E9R3DB01#
			9.4pF	±0.05pF	GJM0222C1E9R4WB01#
				±0.1pF	GJM0222C1E9R4BB01#
				±0.25pF	GJM0222C1E9R4CB01#
				±0.5pF	GJM0222C1E9R4DB01#
			9.5pF	±0.05pF	GJM0222C1E9R5WB01#
				±0.1pF	GJM0222C1E9R5BB01#
				±0.25pF	GJM0222C1E9R5CB01#
				±0.5pF	GJM0222C1E9R5DB01#
			9.6pF	±0.05pF	GJM0222C1E9R6WB01#
				±0.1pF	GJM0222C1E9R6BB01#
				±0.25pF	GJM0222C1E9R6CB01#
				±0.5pF	GJM0222C1E9R6DB01#
			9.7pF	±0.05pF	GJM0222C1E9R7WB01#
				±0.1pF	GJM0222C1E9R7BB01#
				±0.25pF	GJM0222C1E9R7CB01#
				±0.5pF	GJM0222C1E9R7DB01#
			9.8pF	±0.05pF	GJM0222C1E9R8WB01#
				±0.1pF	GJM0222C1E9R8BB01#
				±0.25pF	GJM0222C1E9R8CB01#
				±0.5pF	GJM0222C1E9R8DB01#
			9.9pF	±0.05pF	GJM0222C1E9R9WB01#
				±0.1pF	GJM0222C1E9R9BB01#
				±0.25pF	GJM0222C1E9R9CB01#
				±0.5pF	GJM0222C1E9R9DB01#
			10pF	±2%	GJM0222C1E100GB01#
				±5%	GJM0222C1E100JB01#
			11pF	±2%	GJM0222C1E110GB01#
				±5%	GJM0222C1E110JB01#
			12pF	±2%	GJM0222C1E120GB01#
				±5%	GJM0222C1E120JB01#
13pF	±2%	GJM0222C1E130GB01#			
	±5%	GJM0222C1E130JB01#			
15pF	±2%	GJM0222C1E150GB01#			
	±5%	GJM0222C1E150JB01#			
16pF	±2%	GJM0222C1E160GB01#			
	±5%	GJM0222C1E160JB01#			

T 最大值	额定 电压	温度特 性代号	静电容量	公差	品名
0.22mm	25Vdc	CH	18pF	±2%	GJM0222C1E180GB01#
				±5%	GJM0222C1E180JB01#
			20pF	±2%	GJM0222C1E200GB01#
				±5%	GJM0222C1E200JB01#
			22pF	±2%	GJM0222C1E220GB01#
				±5%	GJM0222C1E220JB01#

■ 0.6×0.3mm **Ultra-compact**

T 最大值	额定 电压	温度特 性代号	静电容量	公差	品名
0.33mm	25Vdc	C0G	0.20pF	±0.05pF	GJM0335C1ER20WB01#
				±0.1pF	GJM0335C1ER20BB01#
			0.30pF	±0.05pF	GJM0335C1ER30WB01#
				±0.1pF	GJM0335C1ER30BB01#
			0.40pF	±0.05pF	GJM0335C1ER40WB01#
				±0.1pF	GJM0335C1ER40BB01#
			0.50pF	±0.05pF	GJM0335C1ER50WB01#
				±0.1pF	GJM0335C1ER50BB01#
			0.60pF	±0.05pF	GJM0335C1ER60WB01#
				±0.1pF	GJM0335C1ER60BB01#
			0.70pF	±0.05pF	GJM0335C1ER70WB01#
				±0.1pF	GJM0335C1ER70BB01#
			0.80pF	±0.05pF	GJM0335C1ER80WB01#
				±0.1pF	GJM0335C1ER80BB01#
			0.90pF	±0.05pF	GJM0335C1ER90WB01#
				±0.1pF	GJM0335C1ER90BB01#
			1.0pF	±0.05pF	GJM0335C1E1R0WB01#
				±0.1pF	GJM0335C1E1R0BB01#
				±0.25pF	GJM0335C1E1R0CB01#
			1.1pF	±0.05pF	GJM0335C1E1R1WB01#
				±0.1pF	GJM0335C1E1R1BB01#
				±0.25pF	GJM0335C1E1R1CB01#
			1.2pF	±0.05pF	GJM0335C1E1R2WB01#
				±0.1pF	GJM0335C1E1R2BB01#
				±0.25pF	GJM0335C1E1R2CB01#
			1.3pF	±0.05pF	GJM0335C1E1R3WB01#
				±0.1pF	GJM0335C1E1R3BB01#
				±0.25pF	GJM0335C1E1R3CB01#
			1.4pF	±0.05pF	GJM0335C1E1R4WB01#
				±0.1pF	GJM0335C1E1R4BB01#
				±0.25pF	GJM0335C1E1R4CB01#
			1.5pF	±0.05pF	GJM0335C1E1R5WB01#
				±0.1pF	GJM0335C1E1R5BB01#
				±0.25pF	GJM0335C1E1R5CB01#
			1.6pF	±0.05pF	GJM0335C1E1R6WB01#
				±0.1pF	GJM0335C1E1R6BB01#
				±0.25pF	GJM0335C1E1R6CB01#
			1.7pF	±0.05pF	GJM0335C1E1R7WB01#
				±0.1pF	GJM0335C1E1R7BB01#
				±0.25pF	GJM0335C1E1R7CB01#
			1.8pF	±0.05pF	GJM0335C1E1R8WB01#
				±0.1pF	GJM0335C1E1R8BB01#
				±0.25pF	GJM0335C1E1R8CB01#

品名 # 表示包装规格代码。

GJM 系列温度补偿型 **高Q** 品名列表

(→ ■ 0.6×0.3mm)

T 最大值	额定 电压	温度特 性代号	静电容量	公差	品名
0.33mm	25Vdc	C0G	1.9pF	±0.05pF	GJM0335C1E1R9WB01#
				±0.1pF	GJM0335C1E1R9BB01#
				±0.25pF	GJM0335C1E1R9CB01#
			2.0pF	±0.05pF	GJM0335C1E2R0WB01#
				±0.1pF	GJM0335C1E2R0BB01#
				±0.25pF	GJM0335C1E2R0CB01#
			2.1pF	±0.05pF	GJM0335C1E2R1WB01#
				±0.1pF	GJM0335C1E2R1BB01#
				±0.25pF	GJM0335C1E2R1CB01#
			2.2pF	±0.05pF	GJM0335C1E2R2WB01#
				±0.1pF	GJM0335C1E2R2BB01#
				±0.25pF	GJM0335C1E2R2CB01#
			2.3pF	±0.05pF	GJM0335C1E2R3WB01#
				±0.1pF	GJM0335C1E2R3BB01#
				±0.25pF	GJM0335C1E2R3CB01#
			2.4pF	±0.05pF	GJM0335C1E2R4WB01#
				±0.1pF	GJM0335C1E2R4BB01#
				±0.25pF	GJM0335C1E2R4CB01#
			2.5pF	±0.05pF	GJM0335C1E2R5WB01#
				±0.1pF	GJM0335C1E2R5BB01#
				±0.25pF	GJM0335C1E2R5CB01#
			2.6pF	±0.05pF	GJM0335C1E2R6WB01#
				±0.1pF	GJM0335C1E2R6BB01#
				±0.25pF	GJM0335C1E2R6CB01#
			2.7pF	±0.05pF	GJM0335C1E2R7WB01#
				±0.1pF	GJM0335C1E2R7BB01#
				±0.25pF	GJM0335C1E2R7CB01#
			2.8pF	±0.05pF	GJM0335C1E2R8WB01#
				±0.1pF	GJM0335C1E2R8BB01#
				±0.25pF	GJM0335C1E2R8CB01#
			2.9pF	±0.05pF	GJM0335C1E2R9WB01#
				±0.1pF	GJM0335C1E2R9BB01#
				±0.25pF	GJM0335C1E2R9CB01#
			3.0pF	±0.05pF	GJM0335C1E3R0WB01#
				±0.1pF	GJM0335C1E3R0BB01#
				±0.25pF	GJM0335C1E3R0CB01#
			3.1pF	±0.05pF	GJM0335C1E3R1WB01#
				±0.1pF	GJM0335C1E3R1BB01#
				±0.25pF	GJM0335C1E3R1CB01#
			3.2pF	±0.05pF	GJM0335C1E3R2WB01#
				±0.1pF	GJM0335C1E3R2BB01#
				±0.25pF	GJM0335C1E3R2CB01#
			3.3pF	±0.05pF	GJM0335C1E3R3WB01#
				±0.1pF	GJM0335C1E3R3BB01#
				±0.25pF	GJM0335C1E3R3CB01#
			3.4pF	±0.05pF	GJM0335C1E3R4WB01#
				±0.1pF	GJM0335C1E3R4BB01#
				±0.25pF	GJM0335C1E3R4CB01#
3.5pF	±0.05pF	GJM0335C1E3R5WB01#			
	±0.1pF	GJM0335C1E3R5BB01#			
	±0.25pF	GJM0335C1E3R5CB01#			
3.6pF	±0.05pF	GJM0335C1E3R6WB01#			
	±0.1pF	GJM0335C1E3R6BB01#			
	±0.25pF	GJM0335C1E3R6CB01#			

T 最大值	额定 电压	温度特 性代号	静电容量	公差	品名
0.33mm	25Vdc	C0G	3.7pF	±0.05pF	GJM0335C1E3R7WB01#
				±0.1pF	GJM0335C1E3R7BB01#
				±0.25pF	GJM0335C1E3R7CB01#
			3.8pF	±0.05pF	GJM0335C1E3R8WB01#
				±0.1pF	GJM0335C1E3R8BB01#
				±0.25pF	GJM0335C1E3R8CB01#
			3.9pF	±0.05pF	GJM0335C1E3R9WB01#
				±0.1pF	GJM0335C1E3R9BB01#
				±0.25pF	GJM0335C1E3R9CB01#
			4.0pF	±0.05pF	GJM0335C1E4R0WB01#
				±0.1pF	GJM0335C1E4R0BB01#
				±0.25pF	GJM0335C1E4R0CB01#
			4.1pF	±0.05pF	GJM0335C1E4R1WB01#
				±0.1pF	GJM0335C1E4R1BB01#
				±0.25pF	GJM0335C1E4R1CB01#
			4.2pF	±0.05pF	GJM0335C1E4R2WB01#
				±0.1pF	GJM0335C1E4R2BB01#
				±0.25pF	GJM0335C1E4R2CB01#
			4.3pF	±0.05pF	GJM0335C1E4R3WB01#
				±0.1pF	GJM0335C1E4R3BB01#
				±0.25pF	GJM0335C1E4R3CB01#
			4.4pF	±0.05pF	GJM0335C1E4R4WB01#
				±0.1pF	GJM0335C1E4R4BB01#
				±0.25pF	GJM0335C1E4R4CB01#
			4.5pF	±0.05pF	GJM0335C1E4R5WB01#
				±0.1pF	GJM0335C1E4R5BB01#
				±0.25pF	GJM0335C1E4R5CB01#
			4.6pF	±0.05pF	GJM0335C1E4R6WB01#
				±0.1pF	GJM0335C1E4R6BB01#
				±0.25pF	GJM0335C1E4R6CB01#
			4.7pF	±0.05pF	GJM0335C1E4R7WB01#
				±0.1pF	GJM0335C1E4R7BB01#
				±0.25pF	GJM0335C1E4R7CB01#
			4.8pF	±0.05pF	GJM0335C1E4R8WB01#
				±0.1pF	GJM0335C1E4R8BB01#
				±0.25pF	GJM0335C1E4R8CB01#
			4.9pF	±0.05pF	GJM0335C1E4R9WB01#
				±0.1pF	GJM0335C1E4R9BB01#
				±0.25pF	GJM0335C1E4R9CB01#
			5.0pF	±0.05pF	GJM0335C1E5R0WB01#
				±0.1pF	GJM0335C1E5R0BB01#
				±0.25pF	GJM0335C1E5R0CB01#
			5.1pF	±0.05pF	GJM0335C1E5R1WB01#
				±0.1pF	GJM0335C1E5R1BB01#
				±0.25pF	GJM0335C1E5R1CB01#
			5.2pF	±0.05pF	GJM0335C1E5R2WB01#
				±0.1pF	GJM0335C1E5R2BB01#
				±0.25pF	GJM0335C1E5R2CB01#
5.3pF	±0.05pF	GJM0335C1E5R3WB01#			
	±0.1pF	GJM0335C1E5R3BB01#			
	±0.25pF	GJM0335C1E5R3CB01#			
5.4pF	±0.05pF	GJM0335C1E5R4WB01#			
	±0.1pF	GJM0335C1E5R4BB01#			
	±0.25pF	GJM0335C1E5R4CB01#			

品名 # 表示包装规格代码。

GRM 系列
GJM 系列
GMA 系列
GMD 系列
GQM 系列
GRJ 系列
GR3 系列
KRM 系列
KR3 系列
LLA 系列
LLL 系列
LLM 系列
LLR 系列
警告/注意事项

GJM 系列温度补偿型 品名列表

(→ ■ 0.6×0.3mm)

T 最大值	额定 电压	温度特 性代号	静电容量	公差	品名
0.33mm	25Vdc	C0G	5.4pF	±0.05pF	GJM0335C1E5R4WB01#
				±0.1pF	GJM0335C1E5R4BB01#
				±0.25pF	GJM0335C1E5R4CB01#
				±0.5pF	GJM0335C1E5R4DB01#
			5.5pF	±0.05pF	GJM0335C1E5R5WB01#
				±0.1pF	GJM0335C1E5R5BB01#
				±0.25pF	GJM0335C1E5R5CB01#
				±0.5pF	GJM0335C1E5R5DB01#
			5.6pF	±0.05pF	GJM0335C1E5R6WB01#
				±0.1pF	GJM0335C1E5R6BB01#
				±0.25pF	GJM0335C1E5R6CB01#
				±0.5pF	GJM0335C1E5R6DB01#
			5.7pF	±0.05pF	GJM0335C1E5R7WB01#
				±0.1pF	GJM0335C1E5R7BB01#
				±0.25pF	GJM0335C1E5R7CB01#
				±0.5pF	GJM0335C1E5R7DB01#
			5.8pF	±0.05pF	GJM0335C1E5R8WB01#
				±0.1pF	GJM0335C1E5R8BB01#
				±0.25pF	GJM0335C1E5R8CB01#
				±0.5pF	GJM0335C1E5R8DB01#
			5.9pF	±0.05pF	GJM0335C1E5R9WB01#
				±0.1pF	GJM0335C1E5R9BB01#
				±0.25pF	GJM0335C1E5R9CB01#
				±0.5pF	GJM0335C1E5R9DB01#
			6.0pF	±0.05pF	GJM0335C1E6R0WB01#
				±0.1pF	GJM0335C1E6R0BB01#
				±0.25pF	GJM0335C1E6R0CB01#
				±0.5pF	GJM0335C1E6R0DB01#
			6.1pF	±0.05pF	GJM0335C1E6R1WB01#
				±0.1pF	GJM0335C1E6R1BB01#
				±0.25pF	GJM0335C1E6R1CB01#
				±0.5pF	GJM0335C1E6R1DB01#
			6.2pF	±0.05pF	GJM0335C1E6R2WB01#
				±0.1pF	GJM0335C1E6R2BB01#
				±0.25pF	GJM0335C1E6R2CB01#
				±0.5pF	GJM0335C1E6R2DB01#
			6.3pF	±0.05pF	GJM0335C1E6R3WB01#
				±0.1pF	GJM0335C1E6R3BB01#
				±0.25pF	GJM0335C1E6R3CB01#
				±0.5pF	GJM0335C1E6R3DB01#
			6.4pF	±0.05pF	GJM0335C1E6R4WB01#
				±0.1pF	GJM0335C1E6R4BB01#
				±0.25pF	GJM0335C1E6R4CB01#
				±0.5pF	GJM0335C1E6R4DB01#
			6.5pF	±0.05pF	GJM0335C1E6R5WB01#
				±0.1pF	GJM0335C1E6R5BB01#
				±0.25pF	GJM0335C1E6R5CB01#
				±0.5pF	GJM0335C1E6R5DB01#
6.6pF	±0.05pF	GJM0335C1E6R6WB01#			
	±0.1pF	GJM0335C1E6R6BB01#			
	±0.25pF	GJM0335C1E6R6CB01#			
	±0.5pF	GJM0335C1E6R6DB01#			
6.7pF	±0.05pF	GJM0335C1E6R7WB01#			
	±0.1pF	GJM0335C1E6R7BB01#			

T 最大值	额定 电压	温度特 性代号	静电容量	公差	品名
0.33mm	25Vdc	C0G	6.7pF	±0.25pF	GJM0335C1E6R7CB01#
				±0.5pF	GJM0335C1E6R7DB01#
			6.8pF	±0.05pF	GJM0335C1E6R8WB01#
				±0.1pF	GJM0335C1E6R8BB01#
				±0.25pF	GJM0335C1E6R8CB01#
			6.9pF	±0.05pF	GJM0335C1E6R9WB01#
				±0.1pF	GJM0335C1E6R9BB01#
				±0.25pF	GJM0335C1E6R9CB01#
			7.0pF	±0.05pF	GJM0335C1E7R0WB01#
				±0.1pF	GJM0335C1E7R0BB01#
				±0.25pF	GJM0335C1E7R0CB01#
			7.1pF	±0.05pF	GJM0335C1E7R1WB01#
				±0.1pF	GJM0335C1E7R1BB01#
				±0.25pF	GJM0335C1E7R1CB01#
			7.2pF	±0.05pF	GJM0335C1E7R2WB01#
				±0.1pF	GJM0335C1E7R2BB01#
				±0.25pF	GJM0335C1E7R2CB01#
			7.3pF	±0.05pF	GJM0335C1E7R3WB01#
				±0.1pF	GJM0335C1E7R3BB01#
				±0.25pF	GJM0335C1E7R3CB01#
			7.4pF	±0.05pF	GJM0335C1E7R4WB01#
				±0.1pF	GJM0335C1E7R4BB01#
				±0.25pF	GJM0335C1E7R4CB01#
			7.5pF	±0.05pF	GJM0335C1E7R5WB01#
				±0.1pF	GJM0335C1E7R5BB01#
				±0.25pF	GJM0335C1E7R5CB01#
			7.6pF	±0.05pF	GJM0335C1E7R6WB01#
				±0.1pF	GJM0335C1E7R6BB01#
				±0.25pF	GJM0335C1E7R6CB01#
			7.7pF	±0.05pF	GJM0335C1E7R7WB01#
				±0.1pF	GJM0335C1E7R7BB01#
				±0.25pF	GJM0335C1E7R7CB01#
			7.8pF	±0.05pF	GJM0335C1E7R8WB01#
				±0.1pF	GJM0335C1E7R8BB01#
				±0.25pF	GJM0335C1E7R8CB01#
			7.9pF	±0.05pF	GJM0335C1E7R9WB01#
				±0.1pF	GJM0335C1E7R9BB01#
				±0.25pF	GJM0335C1E7R9CB01#
			8.0pF	±0.05pF	GJM0335C1E8R0WB01#
				±0.1pF	GJM0335C1E8R0BB01#
				±0.25pF	GJM0335C1E8R0CB01#

品名 # 表示包装规格代码。

- GRM 系列
- GJM 系列
- GMA 系列
- GMD 系列
- GQM 系列
- GRJ 系列
- GR3 系列
- KRM 系列
- KR3 系列
- LJA 系列
- LLL 系列
- LLM 系列
- LLR 系列
- 警告 / 注意事項

GJM 系列温度补偿型 **高Q** 品名列表

(→ ■ 0.6×0.3mm)

T 最大值	额定 电压	温度特 性代号	静电容量	公差	品名
0.33mm	25Vdc	C0G	8.1pF	±0.05pF	GJM0335C1E8R1WB01#
				±0.1pF	GJM0335C1E8R1BB01#
				±0.25pF	GJM0335C1E8R1CB01#
				±0.5pF	GJM0335C1E8R1DB01#
			8.2pF	±0.05pF	GJM0335C1E8R2WB01#
				±0.1pF	GJM0335C1E8R2BB01#
				±0.25pF	GJM0335C1E8R2CB01#
				±0.5pF	GJM0335C1E8R2DB01#
			8.3pF	±0.05pF	GJM0335C1E8R3WB01#
				±0.1pF	GJM0335C1E8R3BB01#
				±0.25pF	GJM0335C1E8R3CB01#
				±0.5pF	GJM0335C1E8R3DB01#
			8.4pF	±0.05pF	GJM0335C1E8R4WB01#
				±0.1pF	GJM0335C1E8R4BB01#
				±0.25pF	GJM0335C1E8R4CB01#
				±0.5pF	GJM0335C1E8R4DB01#
			8.5pF	±0.05pF	GJM0335C1E8R5WB01#
				±0.1pF	GJM0335C1E8R5BB01#
				±0.25pF	GJM0335C1E8R5CB01#
				±0.5pF	GJM0335C1E8R5DB01#
			8.6pF	±0.05pF	GJM0335C1E8R6WB01#
				±0.1pF	GJM0335C1E8R6BB01#
				±0.25pF	GJM0335C1E8R6CB01#
				±0.5pF	GJM0335C1E8R6DB01#
			8.7pF	±0.05pF	GJM0335C1E8R7WB01#
				±0.1pF	GJM0335C1E8R7BB01#
				±0.25pF	GJM0335C1E8R7CB01#
				±0.5pF	GJM0335C1E8R7DB01#
			8.8pF	±0.05pF	GJM0335C1E8R8WB01#
				±0.1pF	GJM0335C1E8R8BB01#
				±0.25pF	GJM0335C1E8R8CB01#
				±0.5pF	GJM0335C1E8R8DB01#
			8.9pF	±0.05pF	GJM0335C1E8R9WB01#
				±0.1pF	GJM0335C1E8R9BB01#
				±0.25pF	GJM0335C1E8R9CB01#
				±0.5pF	GJM0335C1E8R9DB01#
			9.0pF	±0.05pF	GJM0335C1E9R0WB01#
				±0.1pF	GJM0335C1E9R0BB01#
				±0.25pF	GJM0335C1E9R0CB01#
				±0.5pF	GJM0335C1E9R0DB01#
			9.1pF	±0.05pF	GJM0335C1E9R1WB01#
				±0.1pF	GJM0335C1E9R1BB01#
				±0.25pF	GJM0335C1E9R1CB01#
				±0.5pF	GJM0335C1E9R1DB01#
			9.2pF	±0.05pF	GJM0335C1E9R2WB01#
				±0.1pF	GJM0335C1E9R2BB01#
				±0.25pF	GJM0335C1E9R2CB01#
				±0.5pF	GJM0335C1E9R2DB01#
9.3pF	±0.05pF	GJM0335C1E9R3WB01#			
	±0.1pF	GJM0335C1E9R3BB01#			
	±0.25pF	GJM0335C1E9R3CB01#			
	±0.5pF	GJM0335C1E9R3DB01#			
9.4pF	±0.05pF	GJM0335C1E9R4WB01#			
	±0.1pF	GJM0335C1E9R4BB01#			

T 最大值	额定 电压	温度特 性代号	静电容量	公差	品名
0.33mm	25Vdc	C0G	9.4pF	±0.25pF	GJM0335C1E9R4CB01#
				±0.5pF	GJM0335C1E9R4DB01#
			9.5pF	±0.05pF	GJM0335C1E9R5WB01#
				±0.1pF	GJM0335C1E9R5BB01#
				±0.25pF	GJM0335C1E9R5CB01#
			9.6pF	±0.05pF	GJM0335C1E9R6WB01#
				±0.1pF	GJM0335C1E9R6BB01#
				±0.25pF	GJM0335C1E9R6CB01#
			9.7pF	±0.05pF	GJM0335C1E9R7WB01#
				±0.1pF	GJM0335C1E9R7BB01#
				±0.25pF	GJM0335C1E9R7CB01#
			9.8pF	±0.05pF	GJM0335C1E9R8WB01#
				±0.1pF	GJM0335C1E9R8BB01#
				±0.25pF	GJM0335C1E9R8CB01#
			9.9pF	±0.05pF	GJM0335C1E9R9WB01#
				±0.1pF	GJM0335C1E9R9BB01#
				±0.25pF	GJM0335C1E9R9CB01#
			10pF	±2%	GJM0335C1E100GB01#
				±5%	GJM0335C1E100JB01#
			11pF	±2%	GJM0335C1E110GB01#
				±5%	GJM0335C1E110JB01#
			12pF	±2%	GJM0335C1E120GB01#
				±5%	GJM0335C1E120JB01#
			13pF	±2%	GJM0335C1E130GB01#
				±5%	GJM0335C1E130JB01#
			15pF	±2%	GJM0335C1E150GB01#
				±5%	GJM0335C1E150JB01#
			16pF	±2%	GJM0335C1E160GB01#
				±5%	GJM0335C1E160JB01#
			18pF	±2%	GJM0335C1E180GB01#
				±5%	GJM0335C1E180JB01#
			20pF	±2%	GJM0335C1E200GB01#
				±5%	GJM0335C1E200JB01#
			22pF	±2%	GJM0335C1E220GB01#
				±5%	GJM0335C1E220JB01#
			24pF	±2%	GJM0335C1E240GB01#
				±5%	GJM0335C1E240JB01#
			27pF	±2%	GJM0335C1E270GB01#
				±5%	GJM0335C1E270JB01#
			30pF	±2%	GJM0335C1E300GB01#
				±5%	GJM0335C1E300JB01#
			33pF	±2%	GJM0335C1E330GB01#
				±5%	GJM0335C1E330JB01#
			0.20pF	±0.05pF	GJM0334C1ER20WB01#
				±0.1pF	GJM0334C1ER20BB01#
			0.30pF	±0.05pF	GJM0334C1ER30WB01#
				±0.1pF	GJM0334C1ER30BB01#
			0.40pF	±0.05pF	GJM0334C1ER40WB01#
±0.1pF	GJM0334C1ER40BB01#				

品名 # 表示包装规格代码。

GRM 系列
GJM 系列
GMA 系列
GMD 系列
GQM 系列
GRJ 系列
GR3 系列
KRM 系列
KR3 系列
LLA 系列
LLL 系列
LLM 系列
LLR 系列
警告/注意事项

GJM 系列温度补偿型 **高Q** 品名列表

(→ ■ 0.6×0.3mm)

T 最大值	额定 电压	温度特 性代号	静电容量	公差	品名
0.33mm	25Vdc	CK	0.50pF	±0.05pF	GJM0334C1E1R50WB01#
				±0.1pF	GJM0334C1E1R50BB01#
			0.60pF	±0.05pF	GJM0334C1E1R60WB01#
				±0.1pF	GJM0334C1E1R60BB01#
			0.70pF	±0.05pF	GJM0334C1E1R70WB01#
				±0.1pF	GJM0334C1E1R70BB01#
			0.80pF	±0.05pF	GJM0334C1E1R80WB01#
				±0.1pF	GJM0334C1E1R80BB01#
			0.90pF	±0.05pF	GJM0334C1E1R90WB01#
				±0.1pF	GJM0334C1E1R90BB01#
			1.0pF	±0.05pF	GJM0334C1E1R0WB01#
				±0.1pF	GJM0334C1E1R0BB01#
				±0.25pF	GJM0334C1E1R0CB01#
			1.1pF	±0.05pF	GJM0334C1E1R1WB01#
				±0.1pF	GJM0334C1E1R1BB01#
				±0.25pF	GJM0334C1E1R1CB01#
			1.2pF	±0.05pF	GJM0334C1E1R2WB01#
				±0.1pF	GJM0334C1E1R2BB01#
				±0.25pF	GJM0334C1E1R2CB01#
			1.3pF	±0.05pF	GJM0334C1E1R3WB01#
				±0.1pF	GJM0334C1E1R3BB01#
				±0.25pF	GJM0334C1E1R3CB01#
			1.4pF	±0.05pF	GJM0334C1E1R4WB01#
				±0.1pF	GJM0334C1E1R4BB01#
		±0.25pF		GJM0334C1E1R4CB01#	
		1.5pF	±0.05pF	GJM0334C1E1R5WB01#	
			±0.1pF	GJM0334C1E1R5BB01#	
			±0.25pF	GJM0334C1E1R5CB01#	
		1.6pF	±0.05pF	GJM0334C1E1R6WB01#	
			±0.1pF	GJM0334C1E1R6BB01#	
			±0.25pF	GJM0334C1E1R6CB01#	
		1.7pF	±0.05pF	GJM0334C1E1R7WB01#	
			±0.1pF	GJM0334C1E1R7BB01#	
			±0.25pF	GJM0334C1E1R7CB01#	
		1.8pF	±0.05pF	GJM0334C1E1R8WB01#	
			±0.1pF	GJM0334C1E1R8BB01#	
			±0.25pF	GJM0334C1E1R8CB01#	
		1.9pF	±0.05pF	GJM0334C1E1R9WB01#	
			±0.1pF	GJM0334C1E1R9BB01#	
			±0.25pF	GJM0334C1E1R9CB01#	
		2.0pF	±0.05pF	GJM0334C1E2R0WB01#	
			±0.1pF	GJM0334C1E2R0BB01#	
			±0.25pF	GJM0334C1E2R0CB01#	
		CJ	2.1pF	±0.05pF	GJM0333C1E2R1WB01#
				±0.1pF	GJM0333C1E2R1BB01#
				±0.25pF	GJM0333C1E2R1CB01#
			2.2pF	±0.05pF	GJM0333C1E2R2WB01#
				±0.1pF	GJM0333C1E2R2BB01#
±0.25pF	GJM0333C1E2R2CB01#				
2.3pF	±0.05pF		GJM0333C1E2R3WB01#		
	±0.1pF		GJM0333C1E2R3BB01#		
	±0.25pF		GJM0333C1E2R3CB01#		
2.4pF	±0.05pF		GJM0333C1E2R4WB01#		
	±0.1pF		GJM0333C1E2R4BB01#		

T 最大值	额定 电压	温度特 性代号	静电容量	公差	品名
0.33mm	25Vdc	CJ	2.4pF	±0.25pF	GJM0333C1E2R4CB01#
				±0.05pF	GJM0333C1E2R5WB01#
			2.5pF	±0.05pF	GJM0333C1E2R5WB01#
				±0.1pF	GJM0333C1E2R5BB01#
			2.6pF	±0.25pF	GJM0333C1E2R5CB01#
				±0.05pF	GJM0333C1E2R6WB01#
			2.7pF	±0.05pF	GJM0333C1E2R6WB01#
				±0.1pF	GJM0333C1E2R6BB01#
			2.8pF	±0.25pF	GJM0333C1E2R6CB01#
				±0.05pF	GJM0333C1E2R7WB01#
			2.9pF	±0.05pF	GJM0333C1E2R7WB01#
				±0.1pF	GJM0333C1E2R7BB01#
			3.0pF	±0.25pF	GJM0333C1E2R7CB01#
				±0.05pF	GJM0333C1E2R8WB01#
			3.1pF	±0.05pF	GJM0333C1E2R8WB01#
				±0.1pF	GJM0333C1E2R8BB01#
			3.2pF	±0.25pF	GJM0333C1E2R8CB01#
				±0.05pF	GJM0333C1E2R9WB01#
			3.3pF	±0.05pF	GJM0333C1E2R9WB01#
				±0.1pF	GJM0333C1E2R9BB01#
			3.4pF	±0.25pF	GJM0333C1E2R9CB01#
				±0.05pF	GJM0333C1E3R0WB01#
			3.5pF	±0.05pF	GJM0333C1E3R0WB01#
				±0.1pF	GJM0333C1E3R0BB01#
		3.6pF	±0.25pF	GJM0333C1E3R0CB01#	
			±0.05pF	GJM0333C1E3R1WB01#	
		3.7pF	±0.05pF	GJM0333C1E3R1WB01#	
			±0.1pF	GJM0333C1E3R1BB01#	
		3.8pF	±0.25pF	GJM0333C1E3R1CB01#	
			±0.05pF	GJM0333C1E3R2WB01#	
		3.9pF	±0.05pF	GJM0333C1E3R2WB01#	
			±0.1pF	GJM0333C1E3R2BB01#	
		4.0pF	±0.25pF	GJM0333C1E3R2CB01#	
			±0.05pF	GJM0333C1E3R3WB01#	
		4.1pF	±0.05pF	GJM0333C1E3R3WB01#	
			±0.1pF	GJM0333C1E3R3BB01#	
		4.2pF	±0.25pF	GJM0333C1E3R3CB01#	
			±0.05pF	GJM0333C1E3R4WB01#	
		4.3pF	±0.05pF	GJM0333C1E3R4WB01#	
			±0.1pF	GJM0333C1E3R4BB01#	
		4.4pF	±0.25pF	GJM0333C1E3R4CB01#	
			±0.05pF	GJM0333C1E3R5WB01#	
		4.5pF	±0.05pF	GJM0333C1E3R5WB01#	
			±0.1pF	GJM0333C1E3R5BB01#	
		4.6pF	±0.25pF	GJM0333C1E3R5CB01#	
			±0.05pF	GJM0333C1E3R6WB01#	
		4.7pF	±0.05pF	GJM0333C1E3R6WB01#	
			±0.1pF	GJM0333C1E3R6BB01#	
4.8pF	±0.25pF	GJM0333C1E3R6CB01#			
	±0.05pF	GJM0333C1E3R7WB01#			
4.9pF	±0.05pF	GJM0333C1E3R7WB01#			
	±0.1pF	GJM0333C1E3R7BB01#			
5.0pF	±0.25pF	GJM0333C1E3R7CB01#			
	±0.05pF	GJM0333C1E3R8WB01#			
5.1pF	±0.05pF	GJM0333C1E3R8WB01#			
	±0.1pF	GJM0333C1E3R8BB01#			
5.2pF	±0.25pF	GJM0333C1E3R8CB01#			
	±0.05pF	GJM0333C1E3R9WB01#			
5.3pF	±0.05pF	GJM0333C1E3R9WB01#			
	±0.1pF	GJM0333C1E3R9BB01#			
5.4pF	±0.25pF	GJM0333C1E3R9CB01#			
	CH	4.0pF	±0.05pF	GJM0332C1E4R0WB01#	
±0.1pF			GJM0332C1E4R0BB01#		
4.1pF	±0.25pF	GJM0332C1E4R0CB01#			
	±0.05pF	GJM0332C1E4R1WB01#			
4.2pF	±0.05pF	GJM0332C1E4R1WB01#			
	±0.1pF	GJM0332C1E4R1BB01#			
4.3pF	±0.25pF	GJM0332C1E4R1CB01#			
	±0.05pF	GJM0332C1E4R2WB01#			
4.4pF	±0.05pF	GJM0332C1E4R2WB01#			
	±0.1pF	GJM0332C1E4R2BB01#			

品名 # 表示包装规格代码。

GRM 系列
GJM 系列
GMA 系列
GMD 系列
GQM 系列
GRJ 系列
GR3 系列
KRM 系列
KR3 系列
LLA 系列
LLL 系列
LLM 系列
LLR 系列
警告 / 注意事項

GJM 系列温度补偿型 **高Q** 品名列表

(→ ■ 0.6×0.3mm)

T 最大值	额定 电压	温度特 性代号	静电容量	公差	品名	
0.33mm	25Vdc	CH	4.2pF	±0.25pF	GJM0332C1E4R2CB01#	
				±0.05pF	GJM0332C1E4R3WB01#	
					±0.1pF	GJM0332C1E4R3BB01#
					±0.25pF	GJM0332C1E4R3CB01#
			4.4pF	±0.05pF	GJM0332C1E4R4WB01#	
				±0.1pF	GJM0332C1E4R4BB01#	
				±0.25pF	GJM0332C1E4R4CB01#	
			4.5pF	±0.05pF	GJM0332C1E4R5WB01#	
				±0.1pF	GJM0332C1E4R5BB01#	
				±0.25pF	GJM0332C1E4R5CB01#	
			4.6pF	±0.05pF	GJM0332C1E4R6WB01#	
				±0.1pF	GJM0332C1E4R6BB01#	
				±0.25pF	GJM0332C1E4R6CB01#	
			4.7pF	±0.05pF	GJM0332C1E4R7WB01#	
				±0.1pF	GJM0332C1E4R7BB01#	
				±0.25pF	GJM0332C1E4R7CB01#	
			4.8pF	±0.05pF	GJM0332C1E4R8WB01#	
				±0.1pF	GJM0332C1E4R8BB01#	
				±0.25pF	GJM0332C1E4R8CB01#	
			4.9pF	±0.05pF	GJM0332C1E4R9WB01#	
				±0.1pF	GJM0332C1E4R9BB01#	
				±0.25pF	GJM0332C1E4R9CB01#	
			5.0pF	±0.05pF	GJM0332C1E5R0WB01#	
				±0.1pF	GJM0332C1E5R0BB01#	
				±0.25pF	GJM0332C1E5R0CB01#	
			5.1pF	±0.05pF	GJM0332C1E5R1WB01#	
				±0.1pF	GJM0332C1E5R1BB01#	
				±0.25pF	GJM0332C1E5R1CB01#	
				±0.5pF	GJM0332C1E5R1DB01#	
			5.2pF	±0.05pF	GJM0332C1E5R2WB01#	
				±0.1pF	GJM0332C1E5R2BB01#	
				±0.25pF	GJM0332C1E5R2CB01#	
				±0.5pF	GJM0332C1E5R2DB01#	
			5.3pF	±0.05pF	GJM0332C1E5R3WB01#	
				±0.1pF	GJM0332C1E5R3BB01#	
				±0.25pF	GJM0332C1E5R3CB01#	
				±0.5pF	GJM0332C1E5R3DB01#	
			5.4pF	±0.05pF	GJM0332C1E5R4WB01#	
				±0.1pF	GJM0332C1E5R4BB01#	
				±0.25pF	GJM0332C1E5R4CB01#	
				±0.5pF	GJM0332C1E5R4DB01#	
			5.5pF	±0.05pF	GJM0332C1E5R5WB01#	
				±0.1pF	GJM0332C1E5R5BB01#	
				±0.25pF	GJM0332C1E5R5CB01#	
				±0.5pF	GJM0332C1E5R5DB01#	
			5.6pF	±0.05pF	GJM0332C1E5R6WB01#	
				±0.1pF	GJM0332C1E5R6BB01#	
				±0.25pF	GJM0332C1E5R6CB01#	
				±0.5pF	GJM0332C1E5R6DB01#	
			5.7pF	±0.05pF	GJM0332C1E5R7WB01#	
				±0.1pF	GJM0332C1E5R7BB01#	
				±0.25pF	GJM0332C1E5R7CB01#	
				±0.5pF	GJM0332C1E5R7DB01#	
			5.8pF	±0.05pF	GJM0332C1E5R8WB01#	

T 最大值	额定 电压	温度特 性代号	静电容量	公差	品名
0.33mm	25Vdc	CH	5.8pF	±0.1pF	GJM0332C1E5R8BB01#
				±0.25pF	GJM0332C1E5R8CB01#
				±0.5pF	GJM0332C1E5R8DB01#
			5.9pF	±0.05pF	GJM0332C1E5R9WB01#
				±0.1pF	GJM0332C1E5R9BB01#
				±0.25pF	GJM0332C1E5R9CB01#
			6.0pF	±0.05pF	GJM0332C1E6R0WB01#
				±0.1pF	GJM0332C1E6R0BB01#
				±0.25pF	GJM0332C1E6R0CB01#
			6.1pF	±0.05pF	GJM0332C1E6R1WB01#
				±0.1pF	GJM0332C1E6R1BB01#
				±0.25pF	GJM0332C1E6R1CB01#
			6.2pF	±0.05pF	GJM0332C1E6R2WB01#
				±0.1pF	GJM0332C1E6R2BB01#
				±0.25pF	GJM0332C1E6R2CB01#
			6.3pF	±0.05pF	GJM0332C1E6R3WB01#
				±0.1pF	GJM0332C1E6R3BB01#
				±0.25pF	GJM0332C1E6R3CB01#
			6.4pF	±0.05pF	GJM0332C1E6R4WB01#
				±0.1pF	GJM0332C1E6R4BB01#
				±0.25pF	GJM0332C1E6R4CB01#
			6.5pF	±0.05pF	GJM0332C1E6R5WB01#
				±0.1pF	GJM0332C1E6R5BB01#
				±0.25pF	GJM0332C1E6R5CB01#
			6.6pF	±0.05pF	GJM0332C1E6R6WB01#
				±0.1pF	GJM0332C1E6R6BB01#
				±0.25pF	GJM0332C1E6R6CB01#
			6.7pF	±0.05pF	GJM0332C1E6R7WB01#
				±0.1pF	GJM0332C1E6R7BB01#
				±0.25pF	GJM0332C1E6R7CB01#
			6.8pF	±0.05pF	GJM0332C1E6R8WB01#
				±0.1pF	GJM0332C1E6R8BB01#
				±0.25pF	GJM0332C1E6R8CB01#
			6.9pF	±0.05pF	GJM0332C1E6R9WB01#
				±0.1pF	GJM0332C1E6R9BB01#
				±0.25pF	GJM0332C1E6R9CB01#
			7.0pF	±0.05pF	GJM0332C1E7R0WB01#
				±0.1pF	GJM0332C1E7R0BB01#
				±0.25pF	GJM0332C1E7R0CB01#
			7.1pF	±0.05pF	GJM0332C1E7R1WB01#
				±0.1pF	GJM0332C1E7R1BB01#
				±0.25pF	GJM0332C1E7R1CB01#

品名 # 表示包装规格代码。

GRM 系列
GJM 系列
GMA 系列
GMD 系列
GQM 系列
GRJ 系列
GR3 系列
KRM 系列
KR3 系列
LLA 系列
LLL 系列
LLM 系列
LLR 系列
警告/注意事项

GJM 系列温度补偿型 品名列表

(→ ■ 0.6×0.3mm)

T 最大值	额定 电压	温度特 性代号	静电容量	公差	品名	
0.33mm	25Vdc	CH	7.1pF	±0.5pF	GJM0332C1E7R1DB01#	
				7.2pF	±0.05pF	GJM0332C1E7R2WB01#
					±0.1pF	GJM0332C1E7R2BB01#
					±0.25pF	GJM0332C1E7R2CB01#
			7.3pF	±0.5pF	GJM0332C1E7R2DB01#	
				±0.05pF	GJM0332C1E7R3WB01#	
				±0.1pF	GJM0332C1E7R3BB01#	
				±0.25pF	GJM0332C1E7R3CB01#	
			7.4pF	±0.5pF	GJM0332C1E7R3DB01#	
				±0.05pF	GJM0332C1E7R4WB01#	
				±0.1pF	GJM0332C1E7R4BB01#	
			7.5pF	±0.25pF	GJM0332C1E7R4CB01#	
				±0.5pF	GJM0332C1E7R4DB01#	
				±0.05pF	GJM0332C1E7R5WB01#	
				±0.1pF	GJM0332C1E7R5BB01#	
			7.6pF	±0.25pF	GJM0332C1E7R5CB01#	
				±0.5pF	GJM0332C1E7R5DB01#	
				±0.05pF	GJM0332C1E7R6WB01#	
			7.7pF	±0.1pF	GJM0332C1E7R6BB01#	
				±0.25pF	GJM0332C1E7R6CB01#	
				±0.5pF	GJM0332C1E7R6DB01#	
				±0.05pF	GJM0332C1E7R7WB01#	
			7.8pF	±0.1pF	GJM0332C1E7R7BB01#	
				±0.25pF	GJM0332C1E7R7CB01#	
				±0.5pF	GJM0332C1E7R7DB01#	
			7.9pF	±0.05pF	GJM0332C1E7R8WB01#	
				±0.1pF	GJM0332C1E7R8BB01#	
				±0.25pF	GJM0332C1E7R8CB01#	
				±0.5pF	GJM0332C1E7R8DB01#	
			8.0pF	±0.05pF	GJM0332C1E7R9WB01#	
				±0.1pF	GJM0332C1E7R9BB01#	
				±0.25pF	GJM0332C1E7R9CB01#	
				±0.5pF	GJM0332C1E7R9DB01#	
			8.1pF	±0.05pF	GJM0332C1E8R0WB01#	
				±0.1pF	GJM0332C1E8R0BB01#	
				±0.25pF	GJM0332C1E8R0CB01#	
				±0.5pF	GJM0332C1E8R0DB01#	
			8.2pF	±0.05pF	GJM0332C1E8R1WB01#	
				±0.1pF	GJM0332C1E8R1BB01#	
				±0.25pF	GJM0332C1E8R1CB01#	
				±0.5pF	GJM0332C1E8R1DB01#	
			8.3pF	±0.05pF	GJM0332C1E8R2WB01#	
				±0.1pF	GJM0332C1E8R2BB01#	
				±0.25pF	GJM0332C1E8R2CB01#	
				±0.5pF	GJM0332C1E8R2DB01#	
			8.4pF	±0.05pF	GJM0332C1E8R3WB01#	
				±0.1pF	GJM0332C1E8R3BB01#	
				±0.25pF	GJM0332C1E8R3CB01#	
±0.5pF	GJM0332C1E8R3DB01#					
8.5pF	±0.05pF	GJM0332C1E8R4WB01#				
	±0.1pF	GJM0332C1E8R4BB01#				
	±0.25pF	GJM0332C1E8R4CB01#				
	±0.5pF	GJM0332C1E8R4DB01#				

T 最大值	额定 电压	温度特 性代号	静电容量	公差	品名
0.33mm	25Vdc	CH	8.5pF	±0.1pF	GJM0332C1E8R5WB01#
				±0.25pF	GJM0332C1E8R5CB01#
				±0.5pF	GJM0332C1E8R5DB01#
			8.6pF	±0.05pF	GJM0332C1E8R6WB01#
				±0.1pF	GJM0332C1E8R6BB01#
				±0.25pF	GJM0332C1E8R6CB01#
			8.7pF	±0.5pF	GJM0332C1E8R6DB01#
				±0.05pF	GJM0332C1E8R7WB01#
				±0.1pF	GJM0332C1E8R7BB01#
			8.8pF	±0.25pF	GJM0332C1E8R7CB01#
				±0.5pF	GJM0332C1E8R7DB01#
				±0.05pF	GJM0332C1E8R8WB01#
			8.9pF	±0.1pF	GJM0332C1E8R8BB01#
				±0.25pF	GJM0332C1E8R8CB01#
				±0.5pF	GJM0332C1E8R8DB01#
				±0.05pF	GJM0332C1E8R9WB01#
			9.0pF	±0.1pF	GJM0332C1E8R9BB01#
				±0.25pF	GJM0332C1E8R9CB01#
				±0.5pF	GJM0332C1E8R9DB01#
			9.1pF	±0.05pF	GJM0332C1E9R0WB01#
				±0.1pF	GJM0332C1E9R0BB01#
				±0.25pF	GJM0332C1E9R0CB01#
				±0.5pF	GJM0332C1E9R0DB01#
			9.2pF	±0.05pF	GJM0332C1E9R1WB01#
				±0.1pF	GJM0332C1E9R1BB01#
				±0.25pF	GJM0332C1E9R1CB01#
			9.3pF	±0.5pF	GJM0332C1E9R1DB01#
				±0.05pF	GJM0332C1E9R2WB01#
				±0.1pF	GJM0332C1E9R2BB01#
				±0.25pF	GJM0332C1E9R2CB01#
			9.4pF	±0.5pF	GJM0332C1E9R2DB01#
				±0.05pF	GJM0332C1E9R3WB01#
				±0.1pF	GJM0332C1E9R3BB01#
			9.5pF	±0.25pF	GJM0332C1E9R3CB01#
				±0.5pF	GJM0332C1E9R3DB01#
				±0.05pF	GJM0332C1E9R4WB01#
			9.6pF	±0.1pF	GJM0332C1E9R4BB01#
				±0.25pF	GJM0332C1E9R4CB01#
				±0.5pF	GJM0332C1E9R4DB01#
				±0.05pF	GJM0332C1E9R5WB01#
			9.7pF	±0.1pF	GJM0332C1E9R5BB01#
				±0.25pF	GJM0332C1E9R5CB01#
				±0.5pF	GJM0332C1E9R5DB01#
			9.8pF	±0.05pF	GJM0332C1E9R6WB01#
				±0.1pF	GJM0332C1E9R6BB01#
				±0.25pF	GJM0332C1E9R6CB01#
				±0.5pF	GJM0332C1E9R6DB01#

品名 # 表示包装规格代码。

- GRM 系列
- GJM 系列
- GMA 系列
- GMD 系列
- GQM 系列
- GRJ 系列
- GR3 系列
- KRM 系列
- KR3 系列
- LJA 系列
- LLL 系列
- LLM 系列
- LLR 系列
- 警告 / 注意事項

GJM 系列温度补偿型 **高Q** 品名列表

(→ ■ 0.6×0.3mm)

T 最大值	额定 电压	温度特 性代号	静电容量	公差	品名
0.33mm	25Vdc	CH	9.8pF	±0.5pF	GJM0332C1E9R8DB01#
				±0.05pF	GJM0332C1E9R9WB01#
			9.9pF	±0.1pF	GJM0332C1E9R9BB01#
				±0.25pF	GJM0332C1E9R9CB01#
				±0.5pF	GJM0332C1E9R9DB01#
			10pF	±2%	GJM0332C1E100GB01#
				±5%	GJM0332C1E100JB01#
			11pF	±2%	GJM0332C1E110GB01#
				±5%	GJM0332C1E110JB01#
			12pF	±2%	GJM0332C1E120GB01#
				±5%	GJM0332C1E120JB01#
			13pF	±2%	GJM0332C1E130GB01#
				±5%	GJM0332C1E130JB01#
			15pF	±2%	GJM0332C1E150GB01#
				±5%	GJM0332C1E150JB01#
			16pF	±2%	GJM0332C1E160GB01#
				±5%	GJM0332C1E160JB01#
			18pF	±2%	GJM0332C1E180GB01#
				±5%	GJM0332C1E180JB01#
			20pF	±2%	GJM0332C1E200GB01#
				±5%	GJM0332C1E200JB01#
			22pF	±2%	GJM0332C1E220GB01#
				±5%	GJM0332C1E220JB01#
			24pF	±2%	GJM0332C1E240GB01#
				±5%	GJM0332C1E240JB01#
			27pF	±2%	GJM0332C1E270GB01#
				±5%	GJM0332C1E270JB01#
			30pF	±2%	GJM0332C1E300GB01#
				±5%	GJM0332C1E300JB01#
			33pF	±2%	GJM0332C1E330GB01#
				±5%	GJM0332C1E330JB01#

■ 1.0×0.5mm

T 最大值	额定 电压	温度特 性代号	静电容量	公差	品名
0.55mm	50Vdc	C0G	0.10pF	±0.05pF	GJM1555C1HR10WB01#
				±0.1pF	GJM1555C1HR10BB01#
			0.20pF	±0.05pF	GJM1555C1HR20WB01#
				±0.1pF	GJM1555C1HR20BB01#
			0.30pF	±0.05pF	GJM1555C1HR30WB01#
				±0.1pF	GJM1555C1HR30BB01#
			0.40pF	±0.05pF	GJM1555C1HR40WB01#
				±0.1pF	GJM1555C1HR40BB01#
			0.50pF	±0.05pF	GJM1555C1HR50WB01#
				±0.1pF	GJM1555C1HR50BB01#
			0.60pF	±0.05pF	GJM1555C1HR60WB01#
				±0.1pF	GJM1555C1HR60BB01#
			0.70pF	±0.05pF	GJM1555C1HR70WB01#
				±0.1pF	GJM1555C1HR70BB01#
			0.80pF	±0.05pF	GJM1555C1HR80WB01#
				±0.1pF	GJM1555C1HR80BB01#
			0.90pF	±0.05pF	GJM1555C1HR90WB01#
				±0.1pF	GJM1555C1HR90BB01#

T 最大值	额定 电压	温度特 性代号	静电容量	公差	品名
0.55mm	50Vdc	C0G	1.0pF	±0.05pF	GJM1555C1H1R0WB01#
				±0.1pF	GJM1555C1H1R0BB01#
				±0.25pF	GJM1555C1H1R0CB01#
			1.1pF	±0.05pF	GJM1555C1H1R1WB01#
				±0.1pF	GJM1555C1H1R1BB01#
				±0.25pF	GJM1555C1H1R1CB01#
			1.2pF	±0.05pF	GJM1555C1H1R2WB01#
				±0.1pF	GJM1555C1H1R2BB01#
				±0.25pF	GJM1555C1H1R2CB01#
			1.3pF	±0.05pF	GJM1555C1H1R3WB01#
				±0.1pF	GJM1555C1H1R3BB01#
				±0.25pF	GJM1555C1H1R3CB01#
			1.4pF	±0.05pF	GJM1555C1H1R4WB01#
				±0.1pF	GJM1555C1H1R4BB01#
				±0.25pF	GJM1555C1H1R4CB01#
			1.5pF	±0.05pF	GJM1555C1H1R5WB01#
				±0.1pF	GJM1555C1H1R5BB01#
				±0.25pF	GJM1555C1H1R5CB01#
			1.6pF	±0.05pF	GJM1555C1H1R6WB01#
				±0.1pF	GJM1555C1H1R6BB01#
				±0.25pF	GJM1555C1H1R6CB01#
			1.7pF	±0.05pF	GJM1555C1H1R7WB01#
				±0.1pF	GJM1555C1H1R7BB01#
				±0.25pF	GJM1555C1H1R7CB01#
			1.8pF	±0.05pF	GJM1555C1H1R8WB01#
				±0.1pF	GJM1555C1H1R8BB01#
				±0.25pF	GJM1555C1H1R8CB01#
			1.9pF	±0.05pF	GJM1555C1H1R9WB01#
				±0.1pF	GJM1555C1H1R9BB01#
				±0.25pF	GJM1555C1H1R9CB01#
			2.0pF	±0.05pF	GJM1555C1H2R0WB01#
				±0.1pF	GJM1555C1H2R0BB01#
				±0.25pF	GJM1555C1H2R0CB01#
			2.1pF	±0.05pF	GJM1555C1H2R1WB01#
				±0.1pF	GJM1555C1H2R1BB01#
				±0.25pF	GJM1555C1H2R1CB01#
			2.2pF	±0.05pF	GJM1555C1H2R2WB01#
				±0.1pF	GJM1555C1H2R2BB01#
				±0.25pF	GJM1555C1H2R2CB01#
			2.3pF	±0.05pF	GJM1555C1H2R3WB01#
				±0.1pF	GJM1555C1H2R3BB01#
				±0.25pF	GJM1555C1H2R3CB01#
			2.4pF	±0.05pF	GJM1555C1H2R4WB01#
				±0.1pF	GJM1555C1H2R4BB01#
				±0.25pF	GJM1555C1H2R4CB01#
			2.5pF	±0.05pF	GJM1555C1H2R5WB01#
				±0.1pF	GJM1555C1H2R5BB01#
				±0.25pF	GJM1555C1H2R5CB01#
			2.6pF	±0.05pF	GJM1555C1H2R6WB01#
				±0.1pF	GJM1555C1H2R6BB01#
				±0.25pF	GJM1555C1H2R6CB01#
			2.7pF	±0.05pF	GJM1555C1H2R7WB01#
				±0.1pF	GJM1555C1H2R7BB01#
				±0.25pF	GJM1555C1H2R7CB01#

品名 # 表示包装规格代码。

GRM 系列
GJM 系列
GMA 系列
GMD 系列
GQM 系列
GRJ 系列
GR3 系列
KRM 系列
KR3 系列
LLA 系列
LLL 系列
LLM 系列
LLR 系列
警告/注意事项

GJM 系列温度补偿型 品名列表

(→ ■ 1.0×0.5mm)

T 最大值	额定 电压	温度特 性代号	静电容量	公差	品名
0.55mm	50Vdc	COG	2.8pF	±0.05pF	GJM1555C1H2R8WB01#
				±0.1pF	GJM1555C1H2R8BB01#
				±0.25pF	GJM1555C1H2R8CB01#
			2.9pF	±0.05pF	GJM1555C1H2R9WB01#
				±0.1pF	GJM1555C1H2R9BB01#
				±0.25pF	GJM1555C1H2R9CB01#
			3.0pF	±0.05pF	GJM1555C1H3R0WB01#
				±0.1pF	GJM1555C1H3R0BB01#
				±0.25pF	GJM1555C1H3R0CB01#
			3.1pF	±0.05pF	GJM1555C1H3R1WB01#
				±0.1pF	GJM1555C1H3R1BB01#
				±0.25pF	GJM1555C1H3R1CB01#
			3.2pF	±0.05pF	GJM1555C1H3R2WB01#
				±0.1pF	GJM1555C1H3R2BB01#
				±0.25pF	GJM1555C1H3R2CB01#
			3.3pF	±0.05pF	GJM1555C1H3R3WB01#
				±0.1pF	GJM1555C1H3R3BB01#
				±0.25pF	GJM1555C1H3R3CB01#
			3.4pF	±0.05pF	GJM1555C1H3R4WB01#
				±0.1pF	GJM1555C1H3R4BB01#
				±0.25pF	GJM1555C1H3R4CB01#
			3.5pF	±0.05pF	GJM1555C1H3R5WB01#
				±0.1pF	GJM1555C1H3R5BB01#
				±0.25pF	GJM1555C1H3R5CB01#
			3.6pF	±0.05pF	GJM1555C1H3R6WB01#
				±0.1pF	GJM1555C1H3R6BB01#
				±0.25pF	GJM1555C1H3R6CB01#
			3.7pF	±0.05pF	GJM1555C1H3R7WB01#
				±0.1pF	GJM1555C1H3R7BB01#
				±0.25pF	GJM1555C1H3R7CB01#
			3.8pF	±0.05pF	GJM1555C1H3R8WB01#
				±0.1pF	GJM1555C1H3R8BB01#
				±0.25pF	GJM1555C1H3R8CB01#
			3.9pF	±0.05pF	GJM1555C1H3R9WB01#
				±0.1pF	GJM1555C1H3R9BB01#
				±0.25pF	GJM1555C1H3R9CB01#
			4.0pF	±0.05pF	GJM1555C1H4R0WB01#
				±0.1pF	GJM1555C1H4R0BB01#
				±0.25pF	GJM1555C1H4R0CB01#
			4.1pF	±0.05pF	GJM1555C1H4R1WB01#
				±0.1pF	GJM1555C1H4R1BB01#
				±0.25pF	GJM1555C1H4R1CB01#
			4.2pF	±0.05pF	GJM1555C1H4R2WB01#
				±0.1pF	GJM1555C1H4R2BB01#
				±0.25pF	GJM1555C1H4R2CB01#
4.3pF	±0.05pF	GJM1555C1H4R3WB01#			
	±0.1pF	GJM1555C1H4R3BB01#			
	±0.25pF	GJM1555C1H4R3CB01#			
4.4pF	±0.05pF	GJM1555C1H4R4WB01#			
	±0.1pF	GJM1555C1H4R4BB01#			
	±0.25pF	GJM1555C1H4R4CB01#			
4.5pF	±0.05pF	GJM1555C1H4R5WB01#			
	±0.1pF	GJM1555C1H4R5BB01#			
	±0.25pF	GJM1555C1H4R5CB01#			

T 最大值	额定 电压	温度特 性代号	静电容量	公差	品名
0.55mm	50Vdc	COG	4.6pF	±0.05pF	GJM1555C1H4R6WB01#
				±0.1pF	GJM1555C1H4R6BB01#
				±0.25pF	GJM1555C1H4R6CB01#
			4.7pF	±0.05pF	GJM1555C1H4R7WB01#
				±0.1pF	GJM1555C1H4R7BB01#
				±0.25pF	GJM1555C1H4R7CB01#
			4.8pF	±0.05pF	GJM1555C1H4R8WB01#
				±0.1pF	GJM1555C1H4R8BB01#
				±0.25pF	GJM1555C1H4R8CB01#
			4.9pF	±0.05pF	GJM1555C1H4R9WB01#
				±0.1pF	GJM1555C1H4R9BB01#
				±0.25pF	GJM1555C1H4R9CB01#
			5.0pF	±0.05pF	GJM1555C1H5R0WB01#
				±0.1pF	GJM1555C1H5R0BB01#
				±0.25pF	GJM1555C1H5R0CB01#
			5.1pF	±0.05pF	GJM1555C1H5R1WB01#
				±0.1pF	GJM1555C1H5R1BB01#
				±0.25pF	GJM1555C1H5R1CB01#
			5.2pF	±0.05pF	GJM1555C1H5R2WB01#
				±0.1pF	GJM1555C1H5R2BB01#
				±0.25pF	GJM1555C1H5R2CB01#
			5.3pF	±0.05pF	GJM1555C1H5R3WB01#
				±0.1pF	GJM1555C1H5R3BB01#
				±0.25pF	GJM1555C1H5R3CB01#
			5.4pF	±0.05pF	GJM1555C1H5R4WB01#
				±0.1pF	GJM1555C1H5R4BB01#
				±0.25pF	GJM1555C1H5R4CB01#
			5.5pF	±0.05pF	GJM1555C1H5R5WB01#
				±0.1pF	GJM1555C1H5R5BB01#
				±0.25pF	GJM1555C1H5R5CB01#
			5.6pF	±0.05pF	GJM1555C1H5R6WB01#
				±0.1pF	GJM1555C1H5R6BB01#
				±0.25pF	GJM1555C1H5R6CB01#
			5.7pF	±0.05pF	GJM1555C1H5R7WB01#
				±0.1pF	GJM1555C1H5R7BB01#
				±0.25pF	GJM1555C1H5R7CB01#
			5.8pF	±0.05pF	GJM1555C1H5R8WB01#
				±0.1pF	GJM1555C1H5R8BB01#
				±0.25pF	GJM1555C1H5R8CB01#
			5.9pF	±0.05pF	GJM1555C1H5R9WB01#
				±0.1pF	GJM1555C1H5R9BB01#
				±0.25pF	GJM1555C1H5R9CB01#
			6.0pF	±0.05pF	GJM1555C1H6R0WB01#
				±0.1pF	GJM1555C1H6R0BB01#
				±0.25pF	GJM1555C1H6R0CB01#

品名 # 表示包装规格代码。

- GRM 系列
- GJM 系列
- GMA 系列
- GMD 系列
- GQM 系列
- GRJ 系列
- GR3 系列
- KRM 系列
- KR3 系列
- LJA 系列
- LLL 系列
- LJM 系列
- LLR 系列
- 警告 / 注意事項

GJM 系列温度补偿型 **高Q** 品名列表

(→ ■ 1.0×0.5mm)

T 最大值	额定 电压	温度特 性代号	静电容量	公差	品名
0.55mm	50Vdc	COG	6.0pF	±0.5pF	GJM1555C1H6R0DB01#
				±0.05pF	GJM1555C1H6R1WB01#
			6.1pF	±0.1pF	GJM1555C1H6R1BB01#
				±0.25pF	GJM1555C1H6R1CB01#
				±0.5pF	GJM1555C1H6R1DB01#
				6.2pF	±0.05pF
			±0.1pF		GJM1555C1H6R2BB01#
			±0.25pF		GJM1555C1H6R2CB01#
			6.3pF	±0.05pF	GJM1555C1H6R3WB01#
				±0.1pF	GJM1555C1H6R3BB01#
				±0.25pF	GJM1555C1H6R3CB01#
				±0.5pF	GJM1555C1H6R3DB01#
			6.4pF	±0.05pF	GJM1555C1H6R4WB01#
				±0.1pF	GJM1555C1H6R4BB01#
				±0.25pF	GJM1555C1H6R4CB01#
				±0.5pF	GJM1555C1H6R4DB01#
			6.5pF	±0.05pF	GJM1555C1H6R5WB01#
				±0.1pF	GJM1555C1H6R5BB01#
				±0.25pF	GJM1555C1H6R5CB01#
				±0.5pF	GJM1555C1H6R5DB01#
			6.6pF	±0.05pF	GJM1555C1H6R6WB01#
				±0.1pF	GJM1555C1H6R6BB01#
				±0.25pF	GJM1555C1H6R6CB01#
				±0.5pF	GJM1555C1H6R6DB01#
			6.7pF	±0.05pF	GJM1555C1H6R7WB01#
				±0.1pF	GJM1555C1H6R7BB01#
				±0.25pF	GJM1555C1H6R7CB01#
				±0.5pF	GJM1555C1H6R7DB01#
			6.8pF	±0.05pF	GJM1555C1H6R8WB01#
				±0.1pF	GJM1555C1H6R8BB01#
				±0.25pF	GJM1555C1H6R8CB01#
				±0.5pF	GJM1555C1H6R8DB01#
			6.9pF	±0.05pF	GJM1555C1H6R9WB01#
				±0.1pF	GJM1555C1H6R9BB01#
				±0.25pF	GJM1555C1H6R9CB01#
				±0.5pF	GJM1555C1H6R9DB01#
			7.0pF	±0.05pF	GJM1555C1H7R0WB01#
				±0.1pF	GJM1555C1H7R0BB01#
				±0.25pF	GJM1555C1H7R0CB01#
				±0.5pF	GJM1555C1H7R0DB01#
			7.1pF	±0.05pF	GJM1555C1H7R1WB01#
				±0.1pF	GJM1555C1H7R1BB01#
				±0.25pF	GJM1555C1H7R1CB01#
				±0.5pF	GJM1555C1H7R1DB01#
			7.2pF	±0.05pF	GJM1555C1H7R2WB01#
				±0.1pF	GJM1555C1H7R2BB01#
				±0.25pF	GJM1555C1H7R2CB01#
				±0.5pF	GJM1555C1H7R2DB01#
			7.3pF	±0.05pF	GJM1555C1H7R3WB01#
				±0.1pF	GJM1555C1H7R3BB01#
				±0.25pF	GJM1555C1H7R3CB01#
				±0.5pF	GJM1555C1H7R3DB01#
			7.4pF	±0.05pF	GJM1555C1H7R4WB01#

T 最大值	额定 电压	温度特 性代号	静电容量	公差	品名
0.55mm	50Vdc	COG	7.4pF	±0.1pF	GJM1555C1H7R4BB01#
				±0.25pF	GJM1555C1H7R4CB01#
				±0.5pF	GJM1555C1H7R4DB01#
			7.5pF	±0.05pF	GJM1555C1H7R5WB01#
				±0.1pF	GJM1555C1H7R5BB01#
				±0.25pF	GJM1555C1H7R5CB01#
			7.6pF	±0.05pF	GJM1555C1H7R6WB01#
				±0.1pF	GJM1555C1H7R6BB01#
				±0.25pF	GJM1555C1H7R6CB01#
			7.7pF	±0.05pF	GJM1555C1H7R7WB01#
				±0.1pF	GJM1555C1H7R7BB01#
				±0.25pF	GJM1555C1H7R7CB01#
			7.8pF	±0.05pF	GJM1555C1H7R8WB01#
				±0.1pF	GJM1555C1H7R8BB01#
				±0.25pF	GJM1555C1H7R8CB01#
			7.9pF	±0.05pF	GJM1555C1H7R9WB01#
				±0.1pF	GJM1555C1H7R9BB01#
				±0.25pF	GJM1555C1H7R9CB01#
			8.0pF	±0.05pF	GJM1555C1H8R0WB01#
				±0.1pF	GJM1555C1H8R0BB01#
				±0.25pF	GJM1555C1H8R0CB01#
			8.1pF	±0.05pF	GJM1555C1H8R1WB01#
				±0.1pF	GJM1555C1H8R1BB01#
				±0.25pF	GJM1555C1H8R1CB01#
			8.2pF	±0.05pF	GJM1555C1H8R2WB01#
				±0.1pF	GJM1555C1H8R2BB01#
				±0.25pF	GJM1555C1H8R2CB01#
			8.3pF	±0.05pF	GJM1555C1H8R3WB01#
				±0.1pF	GJM1555C1H8R3BB01#
				±0.25pF	GJM1555C1H8R3CB01#
			8.4pF	±0.05pF	GJM1555C1H8R4WB01#
				±0.1pF	GJM1555C1H8R4BB01#
				±0.25pF	GJM1555C1H8R4CB01#
			8.5pF	±0.05pF	GJM1555C1H8R5WB01#
				±0.1pF	GJM1555C1H8R5BB01#
				±0.25pF	GJM1555C1H8R5CB01#
			8.6pF	±0.05pF	GJM1555C1H8R6WB01#
				±0.1pF	GJM1555C1H8R6BB01#
				±0.25pF	GJM1555C1H8R6CB01#
			8.7pF	±0.05pF	GJM1555C1H8R7WB01#
				±0.1pF	GJM1555C1H8R7BB01#
				±0.25pF	GJM1555C1H8R7CB01#

品名 # 表示包装规格代码。

GRM 系列
GJM 系列
GMA 系列
GMD 系列
GQM 系列
GRJ 系列
GR3 系列
KRM 系列
KR3 系列
LLA 系列
LLL 系列
LLM 系列
LLR 系列
警告/注意事项

GJM 系列温度补偿型 **高Q** 品名列表

(→ ■ 1.0×0.5mm)

T 最大值	额定 电压	温度特 性代号	静电容量	公差	品名	
0.55mm	50Vdc	COG	8.7pF	±0.5pF	GJM1555C1H8R7DB01#	
				8.8pF	±0.05pF	GJM1555C1H8R8WB01#
					±0.1pF	GJM1555C1H8R8BB01#
					±0.25pF	GJM1555C1H8R8CB01#
					±0.5pF	GJM1555C1H8R8DB01#
			8.9pF	±0.05pF	GJM1555C1H8R9WB01#	
				±0.1pF	GJM1555C1H8R9BB01#	
				±0.25pF	GJM1555C1H8R9CB01#	
				±0.5pF	GJM1555C1H8R9DB01#	
			9.0pF	±0.05pF	GJM1555C1H9R0WB01#	
				±0.1pF	GJM1555C1H9R0BB01#	
				±0.25pF	GJM1555C1H9R0CB01#	
				±0.5pF	GJM1555C1H9R0DB01#	
			9.1pF	±0.05pF	GJM1555C1H9R1WB01#	
				±0.1pF	GJM1555C1H9R1BB01#	
				±0.25pF	GJM1555C1H9R1CB01#	
				±0.5pF	GJM1555C1H9R1DB01#	
			9.2pF	±0.05pF	GJM1555C1H9R2WB01#	
				±0.1pF	GJM1555C1H9R2BB01#	
				±0.25pF	GJM1555C1H9R2CB01#	
				±0.5pF	GJM1555C1H9R2DB01#	
			9.3pF	±0.05pF	GJM1555C1H9R3WB01#	
				±0.1pF	GJM1555C1H9R3BB01#	
				±0.25pF	GJM1555C1H9R3CB01#	
				±0.5pF	GJM1555C1H9R3DB01#	
			9.4pF	±0.05pF	GJM1555C1H9R4WB01#	
				±0.1pF	GJM1555C1H9R4BB01#	
				±0.25pF	GJM1555C1H9R4CB01#	
				±0.5pF	GJM1555C1H9R4DB01#	
			9.5pF	±0.05pF	GJM1555C1H9R5WB01#	
				±0.1pF	GJM1555C1H9R5BB01#	
				±0.25pF	GJM1555C1H9R5CB01#	
				±0.5pF	GJM1555C1H9R5DB01#	
			9.6pF	±0.05pF	GJM1555C1H9R6WB01#	
				±0.1pF	GJM1555C1H9R6BB01#	
				±0.25pF	GJM1555C1H9R6CB01#	
				±0.5pF	GJM1555C1H9R6DB01#	
			9.7pF	±0.05pF	GJM1555C1H9R7WB01#	
				±0.1pF	GJM1555C1H9R7BB01#	
				±0.25pF	GJM1555C1H9R7CB01#	
				±0.5pF	GJM1555C1H9R7DB01#	
			9.8pF	±0.05pF	GJM1555C1H9R8WB01#	
				±0.1pF	GJM1555C1H9R8BB01#	
				±0.25pF	GJM1555C1H9R8CB01#	
				±0.5pF	GJM1555C1H9R8DB01#	
			9.9pF	±0.05pF	GJM1555C1H9R9WB01#	
				±0.1pF	GJM1555C1H9R9BB01#	
				±0.25pF	GJM1555C1H9R9CB01#	
±0.5pF	GJM1555C1H9R9DB01#					
10pF	±2%	GJM1555C1H100GB01#				
	±5%	GJM1555C1H100JB01#				
11pF	±2%	GJM1555C1H110GB01#				
	±5%	GJM1555C1H110JB01#				
12pF	±2%	GJM1555C1H120GB01#				

T 最大值	额定 电压	温度特 性代号	静电容量	公差	品名	
0.55mm	50Vdc	COG	12pF	±5%	GJM1555C1H120JB01#	
				13pF	±2%	GJM1555C1H130GB01#
					±5%	GJM1555C1H130JB01#
			15pF	±2%	GJM1555C1H150GB01#	
				±5%	GJM1555C1H150JB01#	
			16pF	±2%	GJM1555C1H160GB01#	
				±5%	GJM1555C1H160JB01#	
			18pF	±2%	GJM1555C1H180GB01#	
				±5%	GJM1555C1H180JB01#	
			20pF	±2%	GJM1555C1H200GB01#	
				±5%	GJM1555C1H200JB01#	
			22pF	±1%	GJM1555C1H220FB01#	
				±2%	GJM1555C1H220GB01#	
			24pF	±1%	GJM1555C1H240FB01#	
				±2%	GJM1555C1H240GB01#	
			27pF	±1%	GJM1555C1H270FB01#	
				±2%	GJM1555C1H270GB01#	
			30pF	±1%	GJM1555C1H300FB01#	
				±2%	GJM1555C1H300GB01#	
			33pF	±1%	GJM1555C1H330FB01#	
				±2%	GJM1555C1H330GB01#	
			36pF	±1%	GJM1555C1H360FB01#	
				±2%	GJM1555C1H360GB01#	
			39pF	±1%	GJM1555C1H390FB01#	
				±2%	GJM1555C1H390GB01#	
			43pF	±1%	GJM1555C1H430FB01#	
				±2%	GJM1555C1H430GB01#	
			47pF	±1%	GJM1555C1H470FB01#	
				±2%	GJM1555C1H470GB01#	
			0.10pF	±0.05pF	GJM1554C1HR10WB01#	
				±0.1pF	GJM1554C1HR10BB01#	
			0.20pF	±0.05pF	GJM1554C1HR20WB01#	
				±0.1pF	GJM1554C1HR20BB01#	
			0.30pF	±0.05pF	GJM1554C1HR30WB01#	
				±0.1pF	GJM1554C1HR30BB01#	
			0.40pF	±0.05pF	GJM1554C1HR40WB01#	
		±0.1pF		GJM1554C1HR40BB01#		
		0.50pF	±0.05pF	GJM1554C1HR50WB01#		
			±0.1pF	GJM1554C1HR50BB01#		
		0.60pF	±0.05pF	GJM1554C1HR60WB01#		
			±0.1pF	GJM1554C1HR60BB01#		
		0.70pF	±0.05pF	GJM1554C1HR70WB01#		
			±0.1pF	GJM1554C1HR70BB01#		
		0.80pF	±0.05pF	GJM1554C1HR80WB01#		
			±0.1pF	GJM1554C1HR80BB01#		
		CK	±0.05pF	GJM1554C1HR10WB01#		
			±0.1pF	GJM1554C1HR10BB01#		

品名 # 表示包装规格代码。

GRM 系列
GJM 系列
GMA 系列
GMD 系列
GQM 系列
GRJ 系列
GR3 系列
KRM 系列
KR3 系列
LLA 系列
LLL 系列
LLM 系列
LLR 系列
警告 / 注意事項

GJM 系列温度补偿型 **高Q** 品名列表

(→ ■ 1.0×0.5mm)

T 最大值	额定 电压	温度特 性代号	静电容量	公差	品名
0.55mm	50Vdc	CK	0.90pF	±0.05pF	GJM1554C1HR90WB01#
				±0.1pF	GJM1554C1HR90BB01#
			1.0pF	±0.05pF	GJM1554C1H1R0WB01#
				±0.1pF	GJM1554C1H1R0BB01#
				±0.25pF	GJM1554C1H1R0CB01#
			1.1pF	±0.05pF	GJM1554C1H1R1WB01#
				±0.1pF	GJM1554C1H1R1BB01#
				±0.25pF	GJM1554C1H1R1CB01#
			1.2pF	±0.05pF	GJM1554C1H1R2WB01#
				±0.1pF	GJM1554C1H1R2BB01#
				±0.25pF	GJM1554C1H1R2CB01#
			1.3pF	±0.05pF	GJM1554C1H1R3WB01#
				±0.1pF	GJM1554C1H1R3BB01#
				±0.25pF	GJM1554C1H1R3CB01#
			1.4pF	±0.05pF	GJM1554C1H1R4WB01#
				±0.1pF	GJM1554C1H1R4BB01#
				±0.25pF	GJM1554C1H1R4CB01#
			1.5pF	±0.05pF	GJM1554C1H1R5WB01#
				±0.1pF	GJM1554C1H1R5BB01#
				±0.25pF	GJM1554C1H1R5CB01#
			1.6pF	±0.05pF	GJM1554C1H1R6WB01#
		±0.1pF		GJM1554C1H1R6BB01#	
		±0.25pF		GJM1554C1H1R6CB01#	
		1.7pF	±0.05pF	GJM1554C1H1R7WB01#	
			±0.1pF	GJM1554C1H1R7BB01#	
			±0.25pF	GJM1554C1H1R7CB01#	
		1.8pF	±0.05pF	GJM1554C1H1R8WB01#	
			±0.1pF	GJM1554C1H1R8BB01#	
			±0.25pF	GJM1554C1H1R8CB01#	
		1.9pF	±0.05pF	GJM1554C1H1R9WB01#	
			±0.1pF	GJM1554C1H1R9BB01#	
			±0.25pF	GJM1554C1H1R9CB01#	
		2.0pF	±0.05pF	GJM1554C1H2R0WB01#	
			±0.1pF	GJM1554C1H2R0BB01#	
			±0.25pF	GJM1554C1H2R0CB01#	
		CJ	2.1pF	±0.05pF	GJM1553C1H2R1WB01#
				±0.1pF	GJM1553C1H2R1BB01#
				±0.25pF	GJM1553C1H2R1CB01#
			2.2pF	±0.05pF	GJM1553C1H2R2WB01#
				±0.1pF	GJM1553C1H2R2BB01#
				±0.25pF	GJM1553C1H2R2CB01#
			2.3pF	±0.05pF	GJM1553C1H2R3WB01#
±0.1pF	GJM1553C1H2R3BB01#				
±0.25pF	GJM1553C1H2R3CB01#				
2.4pF	±0.05pF		GJM1553C1H2R4WB01#		
	±0.1pF		GJM1553C1H2R4BB01#		
	±0.25pF		GJM1553C1H2R4CB01#		
2.5pF	±0.05pF		GJM1553C1H2R5WB01#		
	±0.1pF		GJM1553C1H2R5BB01#		
	±0.25pF		GJM1553C1H2R5CB01#		
2.6pF	±0.05pF		GJM1553C1H2R6WB01#		
	±0.1pF		GJM1553C1H2R6BB01#		
	±0.25pF		GJM1553C1H2R6CB01#		
2.7pF	±0.05pF		GJM1553C1H2R7WB01#		

T 最大值	额定 电压	温度特 性代号	静电容量	公差	品名
0.55mm	50Vdc	CJ	2.7pF	±0.1pF	GJM1553C1H2R7BB01#
				±0.25pF	GJM1553C1H2R7CB01#
			2.8pF	±0.05pF	GJM1553C1H2R8WB01#
				±0.1pF	GJM1553C1H2R8BB01#
				±0.25pF	GJM1553C1H2R8CB01#
			2.9pF	±0.05pF	GJM1553C1H2R9WB01#
				±0.1pF	GJM1553C1H2R9BB01#
				±0.25pF	GJM1553C1H2R9CB01#
			3.0pF	±0.05pF	GJM1553C1H3R0WB01#
				±0.1pF	GJM1553C1H3R0BB01#
				±0.25pF	GJM1553C1H3R0CB01#
			3.1pF	±0.05pF	GJM1553C1H3R1WB01#
				±0.1pF	GJM1553C1H3R1BB01#
				±0.25pF	GJM1553C1H3R1CB01#
			3.2pF	±0.05pF	GJM1553C1H3R2WB01#
				±0.1pF	GJM1553C1H3R2BB01#
				±0.25pF	GJM1553C1H3R2CB01#
			3.3pF	±0.05pF	GJM1553C1H3R3WB01#
				±0.1pF	GJM1553C1H3R3BB01#
				±0.25pF	GJM1553C1H3R3CB01#
			3.4pF	±0.05pF	GJM1553C1H3R4WB01#
		±0.1pF		GJM1553C1H3R4BB01#	
		±0.25pF		GJM1553C1H3R4CB01#	
		3.5pF	±0.05pF	GJM1553C1H3R5WB01#	
			±0.1pF	GJM1553C1H3R5BB01#	
			±0.25pF	GJM1553C1H3R5CB01#	
		3.6pF	±0.05pF	GJM1553C1H3R6WB01#	
			±0.1pF	GJM1553C1H3R6BB01#	
			±0.25pF	GJM1553C1H3R6CB01#	
		3.7pF	±0.05pF	GJM1553C1H3R7WB01#	
			±0.1pF	GJM1553C1H3R7BB01#	
			±0.25pF	GJM1553C1H3R7CB01#	
		3.8pF	±0.05pF	GJM1553C1H3R8WB01#	
			±0.1pF	GJM1553C1H3R8BB01#	
			±0.25pF	GJM1553C1H3R8CB01#	
		3.9pF	±0.05pF	GJM1553C1H3R9WB01#	
			±0.1pF	GJM1553C1H3R9BB01#	
			±0.25pF	GJM1553C1H3R9CB01#	
		CH	4.0pF	±0.05pF	GJM1552C1H4R0WB01#
				±0.1pF	GJM1552C1H4R0BB01#
				±0.25pF	GJM1552C1H4R0CB01#
			4.1pF	±0.05pF	GJM1552C1H4R1WB01#
±0.1pF	GJM1552C1H4R1BB01#				
±0.25pF	GJM1552C1H4R1CB01#				
4.2pF	±0.05pF		GJM1552C1H4R2WB01#		
	±0.1pF		GJM1552C1H4R2BB01#		
	±0.25pF		GJM1552C1H4R2CB01#		
4.3pF	±0.05pF		GJM1552C1H4R3WB01#		
	±0.1pF		GJM1552C1H4R3BB01#		
	±0.25pF		GJM1552C1H4R3CB01#		
4.4pF	±0.05pF		GJM1552C1H4R4WB01#		
	±0.1pF		GJM1552C1H4R4BB01#		
	±0.25pF		GJM1552C1H4R4CB01#		
4.5pF	±0.05pF		GJM1552C1H4R5WB01#		

品名 # 表示包装规格代码。

GRM 系列
GJM 系列
GMA 系列
GMD 系列
GQM 系列
GRJ 系列
GR3 系列
KRM 系列
KR3 系列
LLA 系列
LLL 系列
LLM 系列
LLR 系列
警告/注意事项

GJM 系列温度补偿型 品名列表

(→ ■ 1.0×0.5mm)

T 最大值	额定 电压	温度特 性代号	静电容量	公差	品名
0.55mm	50Vdc	CH	4.5pF	±0.1pF	GJM1552C1H4R5BB01#
				±0.25pF	GJM1552C1H4R5CB01#
			4.6pF	±0.05pF	GJM1552C1H4R6WB01#
				±0.1pF	GJM1552C1H4R6BB01#
			4.7pF	±0.25pF	GJM1552C1H4R6CB01#
				±0.05pF	GJM1552C1H4R7WB01#
			4.8pF	±0.1pF	GJM1552C1H4R7BB01#
				±0.25pF	GJM1552C1H4R7CB01#
			4.9pF	±0.05pF	GJM1552C1H4R8WB01#
				±0.1pF	GJM1552C1H4R8BB01#
			5.0pF	±0.25pF	GJM1552C1H4R8CB01#
				±0.05pF	GJM1552C1H4R9WB01#
			5.1pF	±0.1pF	GJM1552C1H4R9BB01#
				±0.25pF	GJM1552C1H4R9CB01#
			5.2pF	±0.05pF	GJM1552C1H5R0WB01#
				±0.1pF	GJM1552C1H5R0BB01#
			5.3pF	±0.25pF	GJM1552C1H5R0CB01#
				±0.05pF	GJM1552C1H5R1WB01#
			5.4pF	±0.1pF	GJM1552C1H5R1BB01#
				±0.25pF	GJM1552C1H5R1CB01#
			5.5pF	±0.5pF	GJM1552C1H5R1DB01#
				±0.05pF	GJM1552C1H5R2WB01#
			5.6pF	±0.1pF	GJM1552C1H5R2BB01#
				±0.25pF	GJM1552C1H5R2CB01#
			5.7pF	±0.5pF	GJM1552C1H5R2DB01#
				±0.05pF	GJM1552C1H5R3WB01#
			5.8pF	±0.1pF	GJM1552C1H5R3BB01#
				±0.25pF	GJM1552C1H5R3CB01#
			5.9pF	±0.5pF	GJM1552C1H5R3DB01#
				±0.05pF	GJM1552C1H5R4WB01#
			6.0pF	±0.1pF	GJM1552C1H5R4BB01#
				±0.25pF	GJM1552C1H5R4CB01#
			6.1pF	±0.5pF	GJM1552C1H5R4DB01#
				±0.05pF	GJM1552C1H5R5WB01#
			6.2pF	±0.1pF	GJM1552C1H5R5BB01#
				±0.25pF	GJM1552C1H5R5CB01#
			6.3pF	±0.5pF	GJM1552C1H5R5DB01#
				±0.05pF	GJM1552C1H5R6WB01#
			6.4pF	±0.1pF	GJM1552C1H5R6BB01#
				±0.25pF	GJM1552C1H5R6CB01#
			6.5pF	±0.5pF	GJM1552C1H5R6DB01#
				±0.05pF	GJM1552C1H5R7WB01#
			6.6pF	±0.1pF	GJM1552C1H5R7BB01#
				±0.25pF	GJM1552C1H5R7CB01#
			6.7pF	±0.5pF	GJM1552C1H5R7DB01#
				±0.05pF	GJM1552C1H5R8WB01#
			6.8pF	±0.1pF	GJM1552C1H5R8BB01#
				±0.25pF	GJM1552C1H5R8CB01#
			6.9pF	±0.5pF	GJM1552C1H5R8DB01#
				±0.05pF	GJM1552C1H5R9WB01#
			7.0pF	±0.1pF	GJM1552C1H5R9BB01#
				±0.25pF	GJM1552C1H5R9CB01#
			7.1pF	±0.5pF	GJM1552C1H5R9DB01#
				±0.05pF	GJM1552C1H6R0WB01#
			7.2pF	±0.1pF	GJM1552C1H6R0BB01#
				±0.25pF	GJM1552C1H6R0CB01#
			7.3pF	±0.5pF	GJM1552C1H6R0DB01#
				±0.05pF	GJM1552C1H6R1WB01#
			7.4pF	±0.1pF	GJM1552C1H6R1BB01#
				±0.25pF	GJM1552C1H6R1CB01#
7.5pF	±0.5pF	GJM1552C1H6R1DB01#			
	±0.05pF	GJM1552C1H6R2WB01#			
7.6pF	±0.1pF	GJM1552C1H6R2BB01#			
	±0.25pF	GJM1552C1H6R2CB01#			
7.7pF	±0.5pF	GJM1552C1H6R2DB01#			
	±0.05pF	GJM1552C1H6R3WB01#			
7.8pF	±0.1pF	GJM1552C1H6R3BB01#			
	±0.25pF	GJM1552C1H6R3CB01#			
7.9pF	±0.5pF	GJM1552C1H6R3DB01#			
	±0.05pF	GJM1552C1H6R4WB01#			
8.0pF	±0.1pF	GJM1552C1H6R4BB01#			
	±0.25pF	GJM1552C1H6R4CB01#			
8.1pF	±0.5pF	GJM1552C1H6R4DB01#			
	±0.05pF	GJM1552C1H6R5WB01#			
8.2pF	±0.1pF	GJM1552C1H6R5BB01#			
	±0.25pF	GJM1552C1H6R5CB01#			
8.3pF	±0.5pF	GJM1552C1H6R5DB01#			
	±0.05pF	GJM1552C1H6R6WB01#			
8.4pF	±0.1pF	GJM1552C1H6R6BB01#			
	±0.25pF	GJM1552C1H6R6CB01#			
8.5pF	±0.5pF	GJM1552C1H6R6DB01#			
	±0.05pF	GJM1552C1H6R7WB01#			
8.6pF	±0.1pF	GJM1552C1H6R7BB01#			
	±0.25pF	GJM1552C1H6R7CB01#			
8.7pF	±0.5pF	GJM1552C1H6R7DB01#			
	±0.05pF	GJM1552C1H6R8WB01#			
8.8pF	±0.1pF	GJM1552C1H6R8BB01#			
	±0.25pF	GJM1552C1H6R8CB01#			
8.9pF	±0.5pF	GJM1552C1H6R8DB01#			
	±0.05pF	GJM1552C1H6R9WB01#			
9.0pF	±0.1pF	GJM1552C1H6R9BB01#			
	±0.25pF	GJM1552C1H6R9CB01#			
9.1pF	±0.5pF	GJM1552C1H6R9DB01#			
	±0.05pF	GJM1552C1H7R0WB01#			
9.2pF	±0.1pF	GJM1552C1H7R0BB01#			
	±0.25pF	GJM1552C1H7R0CB01#			
9.3pF	±0.5pF	GJM1552C1H7R0DB01#			
	±0.05pF	GJM1552C1H7R1WB01#			
9.4pF	±0.1pF	GJM1552C1H7R1BB01#			
	±0.25pF	GJM1552C1H7R1CB01#			
9.5pF	±0.5pF	GJM1552C1H7R1DB01#			
	±0.05pF	GJM1552C1H7R2WB01#			
9.6pF	±0.1pF	GJM1552C1H7R2BB01#			
	±0.25pF	GJM1552C1H7R2CB01#			
9.7pF	±0.5pF	GJM1552C1H7R2DB01#			
	±0.05pF	GJM1552C1H7R3WB01#			
9.8pF	±0.1pF	GJM1552C1H7R3BB01#			
	±0.25pF	GJM1552C1H7R3CB01#			
9.9pF	±0.5pF	GJM1552C1H7R3DB01#			
	±0.05pF	GJM1552C1H7R4WB01#			
10.0pF	±0.1pF	GJM1552C1H7R4BB01#			
	±0.25pF	GJM1552C1H7R4CB01#			

T 最大值	额定 电压	温度特 性代号	静电容量	公差	品名
0.55mm	50Vdc	CH	6.0pF	±0.1pF	GJM1552C1H6R0BB01#
				±0.25pF	GJM1552C1H6R0CB01#
			6.1pF	±0.5pF	GJM1552C1H6R0DB01#
				±0.05pF	GJM1552C1H6R1WB01#
			6.2pF	±0.1pF	GJM1552C1H6R1BB01#
				±0.25pF	GJM1552C1H6R1CB01#
			6.3pF	±0.5pF	GJM1552C1H6R1DB01#
				±0.05pF	GJM1552C1H6R2WB01#
			6.4pF	±0.1pF	GJM1552C1H6R2BB01#
				±0.25pF	GJM1552C1H6R2CB01#
			6.5pF	±0.5pF	GJM1552C1H6R2DB01#
				±0.05pF	GJM1552C1H6R3WB01#
			6.6pF	±0.1pF	GJM1552C1H6R3BB01#
				±0.25pF	GJM1552C1H6R3CB01#
			6.7pF	±0.5pF	GJM1552C1H6R3DB01#
				±0.05pF	GJM1552C1H6R4WB01#
			6.8pF	±0.1pF	GJM1552C1H6R4BB01#
				±0.25pF	GJM1552C1H6R4CB01#
			6.9pF	±0.5pF	GJM1552C1H6R4DB01#
				±0.05pF	GJM1552C1H6R5WB01#
			7.0pF	±0.1pF	GJM1552C1H6R5BB01#
				±0.25pF	GJM1552C1H6R5CB01#
			7.1pF	±0.5pF	GJM1552C1H6R5DB01#
				±0.05pF	GJM1552C1H6R6WB01#
			7.2pF	±0.1pF	GJM1552C1H6R6BB01#
				±0.25pF	GJM1552C1H6R6CB01#
			7.3pF	±0.5pF	GJM1552C1H6R6DB01#
				±0.05pF	GJM1552C1H6R7WB01#
			7.4pF	±0.1pF	GJM1552C1H6R7BB01#
				±0.25pF	GJM1552C1H6R7CB01#
			7.5pF	±0.5pF	GJM1552C1H6R7DB01#
				±0.05pF	GJM1552C1H6R8WB01#
			7.6pF	±0.1pF	GJM1552C1H6R8BB01#
				±0.25pF	GJM1552C1H6R8CB01#
			7.7pF	±0.5pF	GJM1552C1H6R8DB01#
				±0.05pF	GJM1552C1H6R9WB01#
			7.8pF	±0.1pF	GJM1552C1H6R9BB01#
				±0.25pF	GJM1552C1H6R9CB01#
			7.9pF	±0.5pF	GJM1552C1H6R9DB01#
				±0.05pF	GJM1552C1H6R0WB01#
			8.0pF	±0.1pF	GJM1552C1H6R0BB01#
				±0.25pF	GJM1552C1H6R0CB01#
			8.1pF	±0.5pF	GJM1552C1H6R0DB01#
				±0.05pF	GJM1552C1H6R1WB01#
			8.2pF	±0.1pF	GJM1552C1H6R1BB01#
				±0.25pF	GJM1552C1H6R1CB01#
			8.3pF	±0.5pF	GJM1552C1H6R1DB01#
				±0.05pF	GJM1552C1H6R2WB01#
			8.4pF	±0.1pF	GJM1552C1H6R2BB01#
				±0.25pF	GJM1552C1H6R2CB01#
			8.5pF	±0.5pF	GJM1552C1H6R2DB01#
				±0.05pF	GJM1552C1H6R3WB01#
			8.6pF	±0.1pF	GJM1552C1H6R3BB01#
				±0.25pF	GJM1552C1H6R3CB01#
			8.7pF	±0.5pF	GJM1552C1H6R3DB01#
				±0.05pF	GJM1552C1H6R4WB01#
			8.8pF	±0.1pF	GJM1552C1H6R4BB01#
				±0.25pF	GJM1552C1H6R4CB01#
			8.9pF	±0.5pF	GJM1552C1H6R4DB01#
				±0.05pF	GJM1552C1H6R5WB01#
9.0pF	±0.1pF	GJM1552C1H6R5BB01#			
	±0.25pF	GJM1552C1H6R5CB01#			
9.1pF	±0.5pF	GJM1552C1H6R5DB01#			
	±0.05pF	GJM1552C1H6R6WB01#			
9.2pF	±0.1pF	GJM1552C1H6R6BB01#			
	±0.25pF	GJM1552C1H6R6CB01#			
9.3pF	±0.5pF	GJM1552C1H6R6DB01#			
	±0.05pF	GJM1552C1H6R7WB01#			
9.4pF	±0.1pF	GJM1552C1H6R7BB01#			
	±0.25pF	GJM1552C1H6R7CB01#			
9.5pF	±0.5pF	GJM1552C1H6R7DB01#			
	±0.05pF	GJM1552C1H6R8WB01#			
9.6pF	±0.1pF	GJM1552C1H6R8BB01#			
	±0.25pF	GJM1552C1H6R8CB01#			
9.7pF	±0.5pF	GJM1552C1H6R8DB01#			
	±0.05pF	GJM1552C1H6R9WB01#			
9.8pF	±0.1pF	GJM1552C1H6R9BB01#			
	±0.25pF	GJM1552C1H6R9CB01#			
9.9pF	±0.5pF	GJM1552C1H6R9DB01#			
	±0.05pF	GJM1552C1H7R0WB01#			
10.0pF	±0.1pF	GJM1552C1H7R0BB01#			
	±0.25pF	GJM1552C1H7R0CB01#			

品名 # 表示包装规格代码。

- GRM 系列
- GJM 系列
- GMA 系列
- GMD 系列
- GQM 系列
- GRJ 系列
- GR3 系列
- KRM 系列
- KR3 系列
- LJA 系列
- LLL 系列
- LLM 系列
- LLR 系列
- 警告 / 注意事項

GJM 系列温度补偿型 **高Q** 品名列表

(→ ■ 1.0×0.5mm)

T 最大值	额定 电压	温度特 性代号	静电容量	公差	品名
0.55mm	50Vdc	CH	7.3pF	±0.5pF	GJM1552C1H7R3DB01#
				±0.05pF	GJM1552C1H7R4WB01#
			7.4pF	±0.1pF	GJM1552C1H7R4BB01#
				±0.25pF	GJM1552C1H7R4CB01#
				±0.5pF	GJM1552C1H7R4DB01#
				7.5pF	±0.05pF
			±0.1pF		GJM1552C1H7R5BB01#
			±0.25pF		GJM1552C1H7R5CB01#
			7.6pF	±0.05pF	GJM1552C1H7R6WB01#
				±0.1pF	GJM1552C1H7R6BB01#
				±0.25pF	GJM1552C1H7R6CB01#
				±0.5pF	GJM1552C1H7R6DB01#
			7.7pF	±0.05pF	GJM1552C1H7R7WB01#
				±0.1pF	GJM1552C1H7R7BB01#
				±0.25pF	GJM1552C1H7R7CB01#
				±0.5pF	GJM1552C1H7R7DB01#
			7.8pF	±0.05pF	GJM1552C1H7R8WB01#
				±0.1pF	GJM1552C1H7R8BB01#
				±0.25pF	GJM1552C1H7R8CB01#
				±0.5pF	GJM1552C1H7R8DB01#
			7.9pF	±0.05pF	GJM1552C1H7R9WB01#
				±0.1pF	GJM1552C1H7R9BB01#
				±0.25pF	GJM1552C1H7R9CB01#
				±0.5pF	GJM1552C1H7R9DB01#
			8.0pF	±0.05pF	GJM1552C1H8R0WB01#
				±0.1pF	GJM1552C1H8R0BB01#
				±0.25pF	GJM1552C1H8R0CB01#
				±0.5pF	GJM1552C1H8R0DB01#
			8.1pF	±0.05pF	GJM1552C1H8R1WB01#
				±0.1pF	GJM1552C1H8R1BB01#
				±0.25pF	GJM1552C1H8R1CB01#
				±0.5pF	GJM1552C1H8R1DB01#
			8.2pF	±0.05pF	GJM1552C1H8R2WB01#
				±0.1pF	GJM1552C1H8R2BB01#
				±0.25pF	GJM1552C1H8R2CB01#
				±0.5pF	GJM1552C1H8R2DB01#
			8.3pF	±0.05pF	GJM1552C1H8R3WB01#
				±0.1pF	GJM1552C1H8R3BB01#
				±0.25pF	GJM1552C1H8R3CB01#
				±0.5pF	GJM1552C1H8R3DB01#
			8.4pF	±0.05pF	GJM1552C1H8R4WB01#
				±0.1pF	GJM1552C1H8R4BB01#
				±0.25pF	GJM1552C1H8R4CB01#
				±0.5pF	GJM1552C1H8R4DB01#
			8.5pF	±0.05pF	GJM1552C1H8R5WB01#
				±0.1pF	GJM1552C1H8R5BB01#
				±0.25pF	GJM1552C1H8R5CB01#
				±0.5pF	GJM1552C1H8R5DB01#
			8.6pF	±0.05pF	GJM1552C1H8R6WB01#
				±0.1pF	GJM1552C1H8R6BB01#
				±0.25pF	GJM1552C1H8R6CB01#
				±0.5pF	GJM1552C1H8R6DB01#
			8.7pF	±0.05pF	GJM1552C1H8R7WB01#

T 最大值	额定 电压	温度特 性代号	静电容量	公差	品名
0.55mm	50Vdc	CH	8.7pF	±0.1pF	GJM1552C1H8R7BB01#
				±0.25pF	GJM1552C1H8R7CB01#
				±0.5pF	GJM1552C1H8R7DB01#
			8.8pF	±0.05pF	GJM1552C1H8R8WB01#
				±0.1pF	GJM1552C1H8R8BB01#
				±0.25pF	GJM1552C1H8R8CB01#
			8.9pF	±0.05pF	GJM1552C1H8R9WB01#
				±0.1pF	GJM1552C1H8R9BB01#
				±0.25pF	GJM1552C1H8R9CB01#
			9.0pF	±0.05pF	GJM1552C1H9R0WB01#
				±0.1pF	GJM1552C1H9R0BB01#
				±0.25pF	GJM1552C1H9R0CB01#
			9.1pF	±0.05pF	GJM1552C1H9R1WB01#
				±0.1pF	GJM1552C1H9R1BB01#
				±0.25pF	GJM1552C1H9R1CB01#
			9.2pF	±0.05pF	GJM1552C1H9R2WB01#
				±0.1pF	GJM1552C1H9R2BB01#
				±0.25pF	GJM1552C1H9R2CB01#
			9.3pF	±0.05pF	GJM1552C1H9R3WB01#
				±0.1pF	GJM1552C1H9R3BB01#
				±0.25pF	GJM1552C1H9R3CB01#
			9.4pF	±0.05pF	GJM1552C1H9R4WB01#
				±0.1pF	GJM1552C1H9R4BB01#
				±0.25pF	GJM1552C1H9R4CB01#
			9.5pF	±0.05pF	GJM1552C1H9R5WB01#
				±0.1pF	GJM1552C1H9R5BB01#
				±0.25pF	GJM1552C1H9R5CB01#
			9.6pF	±0.05pF	GJM1552C1H9R6WB01#
				±0.1pF	GJM1552C1H9R6BB01#
				±0.25pF	GJM1552C1H9R6CB01#
			9.7pF	±0.05pF	GJM1552C1H9R7WB01#
				±0.1pF	GJM1552C1H9R7BB01#
				±0.25pF	GJM1552C1H9R7CB01#
			9.8pF	±0.05pF	GJM1552C1H9R8WB01#
				±0.1pF	GJM1552C1H9R8BB01#
				±0.25pF	GJM1552C1H9R8CB01#
			9.9pF	±0.05pF	GJM1552C1H9R9WB01#
				±0.1pF	GJM1552C1H9R9BB01#
				±0.25pF	GJM1552C1H9R9CB01#
			10pF	±2%	GJM1552C1H100GB01#
				±5%	GJM1552C1H100JB01#
			11pF	±2%	GJM1552C1H110GB01#

品名 # 表示包装规格代码。

GRM 系列
GJM 系列
GMA 系列
GMD 系列
GQM 系列
GRJ 系列
GR3 系列
KRM 系列
KR3 系列
LLA 系列
LLL 系列
LLM 系列
LLR 系列
警告/注意事项

GJM 系列温度补偿型 品名列表

(→ ■ 1.0×0.5mm)

T 最大值	额定 电压	温度特 性代号	静电容量	公差	品名
0.55mm	50Vdc	CH	11pF	±5%	GJM1552C1H110JB01#
				±2%	GJM1552C1H120GB01#
			12pF	±5%	GJM1552C1H120JB01#
				±2%	GJM1552C1H130GB01#
			13pF	±5%	GJM1552C1H130JB01#
				±2%	GJM1552C1H150GB01#
			15pF	±5%	GJM1552C1H150JB01#
				±2%	GJM1552C1H160GB01#
			16pF	±5%	GJM1552C1H160JB01#
				±2%	GJM1552C1H180GB01#
			18pF	±5%	GJM1552C1H180JB01#
				±2%	GJM1552C1H200GB01#
			20pF	±5%	GJM1552C1H200JB01#
				±1%	GJM1552C1H220FB01#
			22pF	±2%	GJM1552C1H220GB01#
				±5%	GJM1552C1H220JB01#
				±1%	GJM1552C1H240FB01#
			24pF	±2%	GJM1552C1H240GB01#
				±5%	GJM1552C1H240JB01#
				±1%	GJM1552C1H270FB01#
			27pF	±2%	GJM1552C1H270GB01#
				±5%	GJM1552C1H270JB01#
				±1%	GJM1552C1H300FB01#
			30pF	±2%	GJM1552C1H300GB01#
				±5%	GJM1552C1H300JB01#
				±1%	GJM1552C1H330FB01#
			33pF	±2%	GJM1552C1H330GB01#
				±5%	GJM1552C1H330JB01#
				±1%	GJM1552C1H360FB01#
			36pF	±2%	GJM1552C1H360GB01#
				±5%	GJM1552C1H360JB01#
				39pF	±1%
			±2%		GJM1552C1H390GB01#
			±5%		GJM1552C1H390JB01#
			43pF	±1%	GJM1552C1H430FB01#
				±2%	GJM1552C1H430GB01#
				±5%	GJM1552C1H430JB01#
			47pF	±1%	GJM1552C1H470FB01#
				±2%	GJM1552C1H470GB01#
				±5%	GJM1552C1H470JB01#

www.cosc.com

- GRM 系列
- GJM 系列**
- GMA 系列
- GMD 系列
- GQM 系列
- GRJ 系列
- GR3 系列
- KRM 系列
- KR3 系列
- LJA 系列
- LLL 系列
- LJM 系列
- LLR 系列
- 警告 / 注意 事项

品名 # 表示包装规格代码。

结合用上&下电极型

GMA 系列



由于使用了镀金外部电极，因此该电容器非常适合采用引线结合贴装。
 上下电极结构还可以贴装在IC封装上！

特点

① 可实现高密度贴装。

通过减少布线可降低噪声，同时IC封装中的内置电容器可获得高效率。还可使装置小型化。

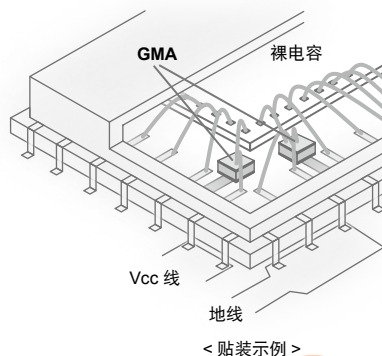
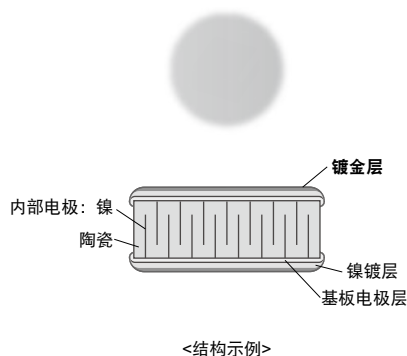

② 旁路应用的理想选择。

多层结构实现了小尺寸和大容量。

③ 卓越的高频特性。

由于电容器由上/下电极结构组成，电流通路变短并降低了ESL。与具有相同容量的一般用GRM系列相比，本产品的阻抗在高频时更低。

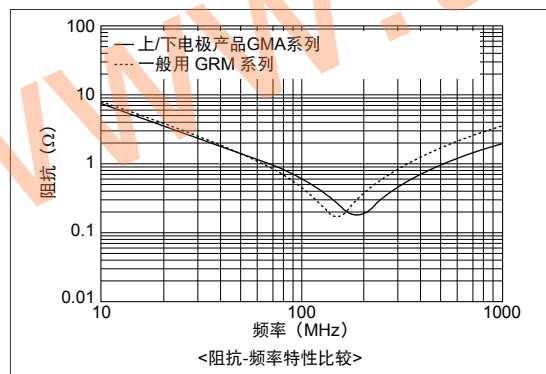

规格

尺寸	0.38×0.38mm 到 0.8×0.8mm
额定电压	DC6.3V 到 100V
静电容量	100pF 到 0.47μF
主要应用	1. 光通信相关设备 2. 各种相关设备，比如GaAsIC（贴装在IC封装上） 3. 测量仪，其他超紧凑/薄设备

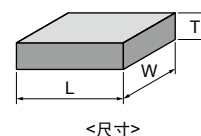

本目录仅列出了部分产品系列。
 详情请参阅村田网站中的电容器检索工具。

GRM 系列
GJM 系列
GMA 系列
GMD 系列
GQM 系列
GRJ 系列
GR3 系列
KRM 系列
KPR3 系列
LLA 系列
LLL 系列
LLM 系列
LLR 系列
警告/注意事项

GMA 系列高介电常数型品名列表

■ 0.38×0.38mm 超小型

T 最大值	额定 电压	温度特 性代号	静电容量	公差	品名	
0.35mm	10Vdc	X7R	1000pF	±20%	GMA0D3R71A102MA01#	
			1500pF	±20%	GMA0D3R71A152MA01#	
			1800pF	±20%	GMA0D3R71A182MA01#	
			10000pF	±20%	GMA0D3R71A103MA01#	
			R	1000pF	±20%	GMA0D3R11A102MA01#
				1500pF	±20%	GMA0D3R11A152MA01#
				1800pF	±20%	GMA0D3R11A182MA01#
		10000pF		±20%	GMA0D3R11A103MA01#	
		B	1000pF	±20%	GMA0D3B11A102MA01#	
			1500pF	±20%	GMA0D3B11A152MA01#	
			1800pF	±20%	GMA0D3B11A182MA01#	

■ 0.5×0.5mm

T 最大值	额定 电压	温度特 性代号	静电容量	公差	品名		
0.4mm	100Vdc	X7R	100pF	±20%	GMA05XR72A101MA01#		
			150pF	±20%	GMA05XR72A151MA01#		
			220pF	±20%	GMA05XR72A221MA01#		
			330pF	±20%	GMA05XR72A331MA01#		
			470pF	±20%	GMA05XR72A471MA01#		
			680pF	±20%	GMA05XR72A681MA01#		
			1000pF	±20%	GMA05XR72A102MA01#		
		25Vdc	X7R	1500pF	±20%	GMA05XR71E152MA11#	
				2200pF	±20%	GMA05XR71E222MA11#	
				3300pF	±20%	GMA05XR71E332MA11#	
				4700pF	±20%	GMA05XR71E472MA11#	
				B	1500pF	±20%	GMA05XB31E152MA11#
					2200pF	±20%	GMA05XB31E222MA11#
					3300pF	±20%	GMA05XB31E332MA11#
	4700pF	±20%	GMA05XB31E472MA11#				
	10Vdc	X7R	6800pF	±20%	GMA05XR71A682MA01#		
			10000pF	±20%	GMA05XR71A103MA01#		
			15000pF	±20%	GMA05XR71A153MA01#		
			22000pF	±20%	GMA05XR71A223MA01#		
			R	6800pF	±20%	GMA05XR11A682MA01#	
				10000pF	±20%	GMA05XR11A103MA01#	
				15000pF	±20%	GMA05XR11A153MA01#	
		22000pF		±20%	GMA05XR11A223MA01#		
		B	6800pF	±20%	GMA05XB11A682MA01#		
			10000pF	±20%	GMA05XB11A103MA01#		
			15000pF	±20%	GMA05XB11A153MA01#		
			22000pF	±20%	GMA05XB11A223MA01#		
			6.3Vdc	X5R	0.10μF	±20%	GMA05XR60J104ME12#
		B			0.10μF	±20%	GMA05XB30J104ME12#

■ 0.8×0.8mm

T 最大值	额定 电压	温度特 性代号	静电容量	公差	品名
0.6mm	100Vdc	X7R	1500pF	±20%	GMA085R72A152MA01#
			2200pF	±20%	GMA085R72A222MA01#

T 最大值	额定 电压	温度特 性代号	静电容量	公差	品名	
0.6mm	100Vdc	X7R	3300pF	±20%	GMA085R72A332MA01#	
			4700pF	±20%	GMA085R72A472MA01#	
			6800pF	±20%	GMA085R72A682MA01#	
		25Vdc	X7R	10000pF	±20%	GMA085R71E103MA11#
				15000pF	±20%	GMA085R71E153MA11#
				22000pF	±20%	GMA085R71E223MA11#
	10Vdc	X7R	10000pF	±20%	GMA085B31E103MA11#	
			15000pF	±20%	GMA085B31E153MA11#	
			22000pF	±20%	GMA085B31E223MA11#	
			R	33000pF	±20%	GMA085R11A333MA01#
		47000pF		±20%	GMA085R11A473MA01#	
		68000pF		±20%	GMA085R11A683MA01#	
		0.10μF		±20%	GMA085R71A104MA01#	
		6.3Vdc	X5R	33000pF	±20%	GMA085R11A333MA01#
	47000pF			±20%	GMA085R11A473MA01#	
	68000pF			±20%	GMA085R11A683MA01#	
	0.10μF			±20%	GMA085R11A104MA01#	
	B		33000pF	±20%	GMA085B11A333MA01#	
			47000pF	±20%	GMA085B11A473MA01#	
			68000pF	±20%	GMA085B11A683MA01#	
0.10μF			±20%	GMA085B11A104MA01#		
6.3Vdc	X5R	0.47μF	±20%	GMA085R60J474ME12#		
		B	0.47μF	±20%	GMA085B30J474ME12#	

品名 # 表示包装规格代码。

GRM 系列
GJM 系列
GMA 系列
GMD 系列
GQM 系列
GRJ 系列
GR3 系列
KRM 系列
KR3 系列
LLA 系列
LLL 系列
LLM 系列
LLR 系列
警告 / 注意事项

结合/金锡焊接用产品

GMD 系列



由于使用了镀金外部电极，因此该电容器可采用引线结合贴装。

特点

① 可通过引线结合和金锡焊接进行贴装。

由于外部电极基于镀金规格，因此可通过引线结合/元件结合来贴装。

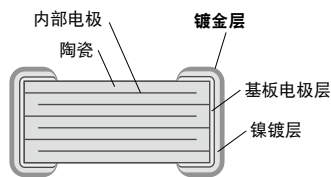

<结构示例>

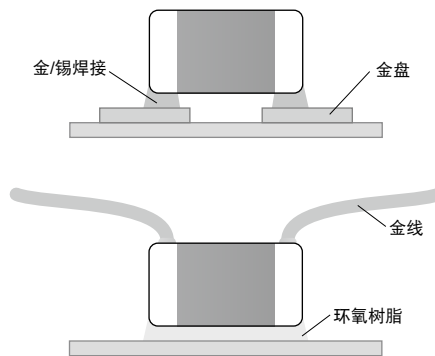

<贴装示例>

② 贴装在如光通信相关设备、IC等封装设备上的理想选择。

通过减少布线可降低噪声，同时通过引线结合贴装，TO-CAN、IC等封装上的内置电容器可获得高效率。

③ 实现了装置的小型化。

村田供应一系列小尺寸产品，比如单位为mm（英寸）的0603（0201）和1005（0402）。

规格

尺寸	0.6×0.3mm 到 1.0×0.5mm
额定电压	DC6.3V 到 50V
静电容量	100pF 到 1.0μF
主要应用	1. 光通信相关设备 2. 贴装在IC封装上。

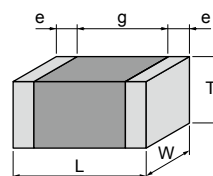

<尺寸>

本目录仅列出了部分产品系列。
 详情请参阅村田网站中的电容器检索工具。

- GRM 系列
- GJM 系列
- GMA 系列
- GMD 系列
- GQM 系列
- GRJ 系列
- GR3 系列
- KRM 系列
- KR3 系列
- LLA 系列
- LLL 系列
- LLM 系列
- LLR 系列
- 警告/注意事项

GMD 系列高介电常数型品名列表

■ 0.6×0.3mm Ultra-compact

T 最大值	额定 电压	温度特 性代号	静电容量	公差	品名	
0.33mm	25Vdc	X7R	100pF	±10%	GMD033R71E101KA01#	
			120pF	±10%	GMD033R71E121KA01#	
			150pF	±10%	GMD033R71E151KA01#	
			180pF	±10%	GMD033R71E181KA01#	
			220pF	±10%	GMD033R71E221KA01#	
			270pF	±10%	GMD033R71E271KA01#	
			330pF	±10%	GMD033R71E331KA01#	
			390pF	±10%	GMD033R71E391KA01#	
			470pF	±10%	GMD033R71E471KA01#	
			560pF	±10%	GMD033R71E561KA01#	
			680pF	±10%	GMD033R71E681KA01#	
			820pF	±10%	GMD033R71E821KA01#	
			1000pF	±10%	GMD033R71E102KA01#	
			1200pF	±10%	GMD033R71E122KA01#	
			1500pF	±10%	GMD033R71E152KA01#	
		R	100pF	±10%	GMD033R11E101KA01#	
			120pF	±10%	GMD033R11E121KA01#	
			150pF	±10%	GMD033R11E151KA01#	
			180pF	±10%	GMD033R11E181KA01#	
			220pF	±10%	GMD033R11E221KA01#	
			270pF	±10%	GMD033R11E271KA01#	
			330pF	±10%	GMD033R11E331KA01#	
			390pF	±10%	GMD033R11E391KA01#	
			470pF	±10%	GMD033R11E471KA01#	
			560pF	±10%	GMD033R11E561KA01#	
			680pF	±10%	GMD033R11E681KA01#	
			820pF	±10%	GMD033R11E821KA01#	
			1000pF	±10%	GMD033R11E102KA01#	
			1200pF	±10%	GMD033R11E122KA01#	
			1500pF	±10%	GMD033R11E152KA01#	
		B	100pF	±10%	GMD033B11E101KA01#	
			120pF	±10%	GMD033B11E121KA01#	
			150pF	±10%	GMD033B11E151KA01#	
			180pF	±10%	GMD033B11E181KA01#	
			220pF	±10%	GMD033B11E221KA01#	
			270pF	±10%	GMD033B11E271KA01#	
			330pF	±10%	GMD033B11E331KA01#	
			390pF	±10%	GMD033B11E391KA01#	
			470pF	±10%	GMD033B11E471KA01#	
			560pF	±10%	GMD033B11E561KA01#	
			680pF	±10%	GMD033B11E681KA01#	
			820pF	±10%	GMD033B11E821KA01#	
			1000pF	±10%	GMD033B11E102KA01#	
			1200pF	±10%	GMD033B11E122KA01#	
			1500pF	±10%	GMD033B11E152KA01#	
	16Vdc	X7R	1800pF	±10%	GMD033R71C182KA11#	
			2200pF	±10%	GMD033R71C222KA11#	
			2700pF	±10%	GMD033R71C272KA11#	
			3300pF	±10%	GMD033R71C332KA11#	
			R	1800pF	±10%	GMD033R11C182KA11#
				2200pF	±10%	GMD033R11C222KA11#
				2700pF	±10%	GMD033R11C272KA11#
				3300pF	±10%	GMD033R11C332KA11#
				2700pF	±10%	GMD033R11C272KA11#

T 最大值	额定 电压	温度特 性代号	静电容量	公差	品名	
0.33mm	16Vdc	R	3300pF	±10%	GMD033R11C332KA11#	
			1800pF	±10%	GMD033B31C182KA11#	
			2200pF	±10%	GMD033B31C222KA11#	
			2700pF	±10%	GMD033B31C272KA11#	
		10Vdc	X7R	3900pF	±10%	GMD033R71A392KA01#
				4700pF	±10%	GMD033R71A472KA01#
				5600pF	±10%	GMD033R71A562KA01#
				6800pF	±10%	GMD033R71A682KA01#
			R	8200pF	±10%	GMD033R71A822KA01#
				10000pF	±10%	GMD033R71A103KA01#
				3900pF	±10%	GMD033R11A392KA01#
				4700pF	±10%	GMD033R11A472KA01#
	6.3Vdc	X5R	56000pF	±10%	GMD033R60J563KE11#	
			68000pF	±10%	GMD033R60J683KE11#	
			82000pF	±10%	GMD033R60J823KE11#	
			0.10μF	±10%	GMD033R60J104KE11#	
			B	56000pF	±10%	GMD033B30J563KE11#
				68000pF	±10%	GMD033B30J683KE11#
		82000pF		±10%	GMD033B30J823KE11#	
		0.10μF		±10%	GMD033B30J104KE11#	

■ 1.0×0.5mm

T 最大值	额定 电压	温度特 性代号	静电容量	公差	品名	
0.55mm	50Vdc	X7R	220pF	±10%	GMD155R71H221KA01#	
			270pF	±10%	GMD155R71H271KA01#	
			330pF	±10%	GMD155R71H331KA01#	
			390pF	±10%	GMD155R71H391KA01#	
			470pF	±10%	GMD155R71H471KA01#	
			560pF	±10%	GMD155R71H561KA01#	
			680pF	±10%	GMD155R71H681KA01#	
			820pF	±10%	GMD155R71H821KA01#	
			1000pF	±10%	GMD155R71H102KA01#	
			1200pF	±10%	GMD155R71H122KA01#	
			1500pF	±10%	GMD155R71H152KA01#	
			1800pF	±10%	GMD155R71H182KA01#	
			2200pF	±10%	GMD155R71H222KA01#	
			2700pF	±10%	GMD155R71H272KA01#	
			3300pF	±10%	GMD155R71H332KA01#	
			3900pF	±10%	GMD155R71H392KA01#	
			4700pF	±10%	GMD155R71H472KA01#	
			R	220pF	±10%	GMD155R11H221KA01#

品名 # 表示包装规格代码。

GRM 系列
GJM 系列
GMA 系列
GMD 系列
GQM 系列
GRJ 系列
GR3 系列
KRM 系列
KR3 系列
LLA 系列
LLL 系列
LLM 系列
LLR 系列
警告 / 注意事項

GMD 系列高介电常数型品名列表

(→ ■ 1.0×0.5mm)

T 最大值	额定 电压	温度特 性代号	静电容量	公差	品名		
0.55mm	50Vdc	R	270pF	±10%	GMD155R11H271KA01#		
			330pF	±10%	GMD155R11H331KA01#		
			390pF	±10%	GMD155R11H391KA01#		
			470pF	±10%	GMD155R11H471KA01#		
			560pF	±10%	GMD155R11H561KA01#		
			680pF	±10%	GMD155R11H681KA01#		
			820pF	±10%	GMD155R11H821KA01#		
			1000pF	±10%	GMD155R11H102KA01#		
			1200pF	±10%	GMD155R11H122KA01#		
			1500pF	±10%	GMD155R11H152KA01#		
			1800pF	±10%	GMD155R11H182KA01#		
			2200pF	±10%	GMD155R11H222KA01#		
			2700pF	±10%	GMD155R11H272KA01#		
			3300pF	±10%	GMD155R11H332KA01#		
			3900pF	±10%	GMD155R11H392KA01#		
			4700pF	±10%	GMD155R11H472KA01#		
			B	220pF	±10%	GMD155B11H221KA01#	
				270pF	±10%	GMD155B11H271KA01#	
				330pF	±10%	GMD155B11H331KA01#	
				390pF	±10%	GMD155B11H391KA01#	
				470pF	±10%	GMD155B11H471KA01#	
		560pF		±10%	GMD155B11H561KA01#		
		680pF		±10%	GMD155B11H681KA01#		
		820pF		±10%	GMD155B11H821KA01#		
		1000pF		±10%	GMD155B11H102KA01#		
		1200pF		±10%	GMD155B11H122KA01#		
		1500pF		±10%	GMD155B11H152KA01#		
		1800pF		±10%	GMD155B11H182KA01#		
		2200pF		±10%	GMD155B11H222KA01#		
		2700pF		±10%	GMD155B11H272KA01#		
		3300pF		±10%	GMD155B11H332KA01#		
		3900pF		±10%	GMD155B11H392KA01#		
		4700pF		±10%	GMD155B11H472KA01#		
		25Vdc		X7R	5600pF	±10%	GMD155R71E562KA01#
					6800pF	±10%	GMD155R71E682KA01#
					8200pF	±10%	GMD155R71E822KA01#
					10000pF	±10%	GMD155R71E103KA01#
					12000pF	±10%	GMD155R71E123KA01#
					15000pF	±10%	GMD155R71E153KA01#
					18000pF	±10%	GMD155R71E183KA01#
					22000pF	±10%	GMD155R71E223KA01#
					27000pF	±10%	GMD155R71E273KA11#
			33000pF		±10%	GMD155R71E333KA11#	
			39000pF		±10%	GMD155R71E393KA11#	
			47000pF		±10%	GMD155R71E473KA11#	
			R		5600pF	±10%	GMD155R11E562KA01#
					6800pF	±10%	GMD155R11E682KA01#
8200pF	±10%				GMD155R11E822KA01#		
10000pF	±10%				GMD155R11E103KA01#		
12000pF	±10%				GMD155R11E123KA01#		
15000pF	±10%				GMD155R11E153KA01#		
18000pF	±10%				GMD155R11E183KA01#		
22000pF	±10%				GMD155R11E223KA01#		
27000pF	±10%	GMD155R11E273KA11#					

T 最大值	额定 电压	温度特 性代号	静电容量	公差	品名			
0.55mm	25Vdc	R	33000pF	±10%	GMD155R11E333KA11#			
			39000pF	±10%	GMD155R11E393KA11#			
			47000pF	±10%	GMD155R11E473KA11#			
			B	5600pF	±10%	GMD155B11E562KA01#		
				6800pF	±10%	GMD155B11E682KA01#		
				8200pF	±10%	GMD155B11E822KA01#		
				10000pF	±10%	GMD155B11E103KA01#		
				12000pF	±10%	GMD155B11E123KA01#		
				15000pF	±10%	GMD155B11E153KA01#		
		18000pF	±10%	GMD155B11E183KA01#				
		22000pF	±10%	GMD155B11E223KA01#				
		27000pF	±10%	GMD155B31E273KA11#				
		33000pF	±10%	GMD155B31E333KA11#				
		39000pF	±10%	GMD155B31E393KA11#				
		47000pF	±10%	GMD155B31E473KA11#				
		16Vdc	X7R	56000pF	±10%	GMD155R71C563KA11#		
				68000pF	±10%	GMD155R71C683KA11#		
				82000pF	±10%	GMD155R71C823KA11#		
				0.10μF	±10%	GMD155R71C104KA11#		
				R	56000pF	±10%	GMD155R11C563KA11#	
					68000pF	±10%	GMD155R11C683KA11#	
			82000pF		±10%	GMD155R11C823KA11#		
			0.10μF		±10%	GMD155R11C104KA11#		
			B		56000pF	±10%	GMD155B31C563KA11#	
					68000pF	±10%	GMD155B31C683KA11#	
				82000pF	±10%	GMD155B31C823KA11#		
				0.10μF	±10%	GMD155B31C104KA11#		
				10Vdc	X5R	0.12μF	±10%	GMD155R61A124KE12#
						0.15μF	±10%	GMD155R61A154KE12#
			0.18μF			±10%	GMD155R61A184KE12#	
			0.22μF			±10%	GMD155R61A224KE12#	
			0.27μF			±10%	GMD155R61A274KE11#	
			0.33μF			±10%	GMD155R61A334KE11#	
		0.39μF	±10%		GMD155R61A394KE11#			
		0.47μF	±10%		GMD155R61A474KE11#			
		B	0.12μF		±10%	GMD155B31A124KE12#		
			0.15μF		±10%	GMD155B31A154KE12#		
			0.18μF		±10%	GMD155B31A184KE12#		
			0.22μF		±10%	GMD155B31A224KE12#		
			0.27μF	±10%	GMD155B31A274KE11#			
			0.33μF	±10%	GMD155B31A334KE11#			
		0.39μF	±10%	GMD155B31A394KE11#				
		0.47μF	±10%	GMD155B31A474KE11#				

- GRM 系列
- GJM 系列
- GMA 系列
- GMD 系列
- GQM 系列
- GRJ 系列
- GR3 系列
- KRM 系列
- KR3 系列
- LLA 系列
- LLL 系列
- LLM 系列
- LLR 系列
- 警告 / 注意事项

品名 # 表示包装规格代码。

GRM 系列

GJM 系列

GMA 系列

GMD 系列

GQM 系列

GRJ 系列

GR3 系列

KRM 系列

KR3 系列

L1A 系列

L1L 系列

L1M 系列

L1R 系列

警告 / 注意事项

高频型 高Q型 1608 (单位: mm) / 0603 (单位: 英寸) 最小尺寸

GQM 系列



基站PA设计理想的高频电容器

特点

- ① 非常适合用于移动通信设备的基站及相关模块的温度补偿。

本产品非常适合用于高频电路的温度补偿，例如设备的工作特性受电容波动严重影响的谐振电路、调谐电路及阻抗匹配电路。

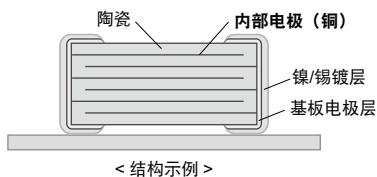

< 结构示例 >

- ② 在VHF、UHF 和微波频段时高Q和低ESR。

通过使用陶瓷材料作为在高频下能实现超低损耗的介电材料，以及使用金属基板电极作为内部电极，在高频下获得了高Q值和低ESR。

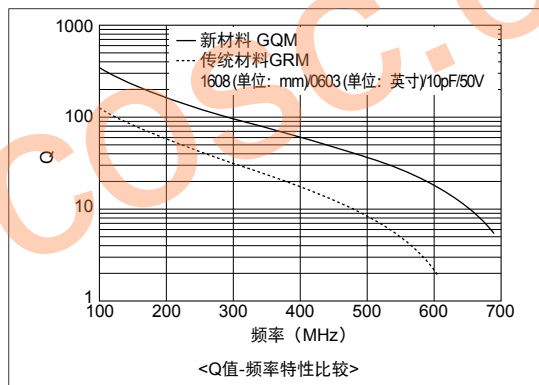
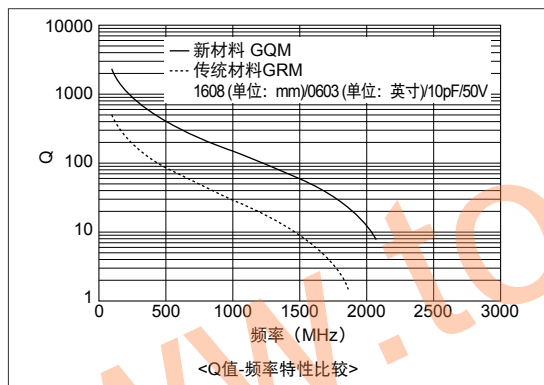

- ③ 可用于对公差要求严格的应用。

除标准公差外，本产品的可允许公差范围还适合于以下窄公差。

静电容量范围	标准静电容量公差 (静电容量公差符号)	窄静电容量公差 (静电容量公差符号)
<=0.9pF	±0.1pF (B)	±0.05pF (W)
1.0 到 5.0pF	±0.25pF (C)	±0.05pF (W), ±0.1pF (B)
5.1 到 9.9pF	±0.5pF (D)	±0.05pF (W), ±0.1pF (B), ±0.25pF (C)
>=10pF	±5% (J)	±2% (G)

规格

尺寸	1.0×0.5mm 到 2.8×2.8mm
额定电压	DC50V 到 500V
静电容量	0.1pF 到 200pF
主要应用	手机基站

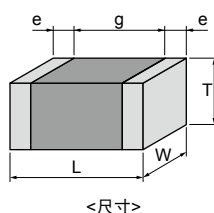

本目录仅列出了部分产品系列。
 详情请参阅村田网站中的电容器检索工具。

GQM 系列温度补偿型 品名列表

■ 1.6×0.8mm

T 最大值	额定 电压	温度特 性代号	静电容量	公差	品名
0.8mm	250Vdc	COG	1.0pF	±0.1pF	GQM1875C2E1R0BB12#
				±0.25pF	GQM1875C2E1R0CB12#
			1.1pF	±0.1pF	GQM1875C2E1R1BB12#
				±0.25pF	GQM1875C2E1R1CB12#
			1.2pF	±0.1pF	GQM1875C2E1R2BB12#
				±0.25pF	GQM1875C2E1R2CB12#
			1.3pF	±0.1pF	GQM1875C2E1R3BB12#
				±0.25pF	GQM1875C2E1R3CB12#
			1.5pF	±0.1pF	GQM1875C2E1R5BB12#
				±0.25pF	GQM1875C2E1R5CB12#
			1.6pF	±0.1pF	GQM1875C2E1R6BB12#
				±0.25pF	GQM1875C2E1R6CB12#
			1.8pF	±0.1pF	GQM1875C2E1R8BB12#
				±0.25pF	GQM1875C2E1R8CB12#
			2.0pF	±0.1pF	GQM1875C2E2R0BB12#
				±0.25pF	GQM1875C2E2R0CB12#
			2.2pF	±0.1pF	GQM1875C2E2R2BB12#
				±0.25pF	GQM1875C2E2R2CB12#
			2.4pF	±0.1pF	GQM1875C2E2R4BB12#
				±0.25pF	GQM1875C2E2R4CB12#
			2.7pF	±0.1pF	GQM1875C2E2R7BB12#
				±0.25pF	GQM1875C2E2R7CB12#
			3.0pF	±0.1pF	GQM1875C2E3R0BB12#
				±0.25pF	GQM1875C2E3R0CB12#
			3.3pF	±0.1pF	GQM1875C2E3R3BB12#
				±0.25pF	GQM1875C2E3R3CB12#
			3.6pF	±0.1pF	GQM1875C2E3R6BB12#
				±0.25pF	GQM1875C2E3R6CB12#
			3.9pF	±0.1pF	GQM1875C2E3R9BB12#
				±0.25pF	GQM1875C2E3R9CB12#
			4.0pF	±0.1pF	GQM1875C2E4R0BB12#
				±0.25pF	GQM1875C2E4R0CB12#
			4.3pF	±0.1pF	GQM1875C2E4R3BB12#
				±0.25pF	GQM1875C2E4R3CB12#
			4.7pF	±0.1pF	GQM1875C2E4R7BB12#
				±0.25pF	GQM1875C2E4R7CB12#
			5.0pF	±0.1pF	GQM1875C2E5R0BB12#
				±0.25pF	GQM1875C2E5R0CB12#
			5.1pF	±0.25pF	GQM1875C2E5R1CB12#
				±0.5pF	GQM1875C2E5R1DB12#
			5.6pF	±0.25pF	GQM1875C2E5R6CB12#
				±0.5pF	GQM1875C2E5R6DB12#
			6.0pF	±0.25pF	GQM1875C2E6R0CB12#
				±0.5pF	GQM1875C2E6R0DB12#
			6.2pF	±0.25pF	GQM1875C2E6R2CB12#
				±0.5pF	GQM1875C2E6R2DB12#
			6.8pF	±0.25pF	GQM1875C2E6R8CB12#
				±0.5pF	GQM1875C2E6R8DB12#
7.0pF	±0.25pF	GQM1875C2E7R0CB12#			
	±0.5pF	GQM1875C2E7R0DB12#			
7.5pF	±0.25pF	GQM1875C2E7R5CB12#			
	±0.5pF	GQM1875C2E7R5DB12#			

T 最大值	额定 电压	温度特 性代号	静电容量	公差	品名			
0.8mm	250Vdc	COG	8.0pF	±0.25pF	GQM1875C2E8R0CB12#			
				±0.5pF	GQM1875C2E8R0DB12#			
			8.2pF	±0.25pF	GQM1875C2E8R2CB12#			
				±0.5pF	GQM1875C2E8R2DB12#			
			9.0pF	±0.25pF	GQM1875C2E9R0CB12#			
				±0.5pF	GQM1875C2E9R0DB12#			
			9.1pF	±0.25pF	GQM1875C2E9R1CB12#			
				±0.5pF	GQM1875C2E9R1DB12#			
			10pF	±2%	GQM1875C2E100GB12#			
				±5%	GQM1875C2E100JB12#			
			11pF	±2%	GQM1875C2E110GB12#			
				±5%	GQM1875C2E110JB12#			
			12pF	±2%	GQM1875C2E120GB12#			
				±5%	GQM1875C2E120JB12#			
			13pF	±2%	GQM1875C2E130GB12#			
				±5%	GQM1875C2E130JB12#			
			15pF	±2%	GQM1875C2E150GB12#			
				±5%	GQM1875C2E150JB12#			
			16pF	±2%	GQM1875C2E160GB12#			
				±5%	GQM1875C2E160JB12#			
			18pF	±2%	GQM1875C2E180GB12#			
				±5%	GQM1875C2E180JB12#			
			20pF	±2%	GQM1875C2E200GB12#			
				±5%	GQM1875C2E200JB12#			
			22pF	±2%	GQM1875C2E220GB12#			
				±5%	GQM1875C2E220JB12#			
			24pF	±2%	GQM1875C2E240GB12#			
				±5%	GQM1875C2E240JB12#			
			27pF	±2%	GQM1875C2E270GB12#			
				±5%	GQM1875C2E270JB12#			
			30pF	±2%	GQM1875C2E300GB12#			
				±5%	GQM1875C2E300JB12#			
			33pF	±2%	GQM1875C2E330GB12#			
				±5%	GQM1875C2E330JB12#			
			36pF	±2%	GQM1875C2E360GB12#			
				±5%	GQM1875C2E360JB12#			
			39pF	±2%	GQM1875C2E390GB12#			
				±5%	GQM1875C2E390JB12#			
			43pF	±2%	GQM1875C2E430GB12#			
				±5%	GQM1875C2E430JB12#			
			47pF	±2%	GQM1875C2E470GB12#			
				±5%	GQM1875C2E470JB12#			
			0.9mm	100Vdc	COG	1.0pF	±0.1pF	GQM1885C2A1R0BB01#
							±0.25pF	GQM1885C2A1R0CB01#
						1.1pF	±0.1pF	GQM1885C2A1R1BB01#
							±0.25pF	GQM1885C2A1R1CB01#
						1.2pF	±0.1pF	GQM1885C2A1R2BB01#
							±0.25pF	GQM1885C2A1R2CB01#
1.3pF	±0.1pF	GQM1885C2A1R3BB01#						
	±0.25pF	GQM1885C2A1R3CB01#						
1.5pF	±0.1pF	GQM1885C2A1R5BB01#						
	±0.25pF	GQM1885C2A1R5CB01#						
1.6pF	±0.1pF	GQM1885C2A1R6BB01#						
	±0.25pF	GQM1885C2A1R6CB01#						

品名 # 表示包装规格代码。

GRM 系列
GJM 系列
GMA 系列
GMD 系列
GQM 系列
GRJ 系列
GR3 系列
KRM 系列
KR3 系列
LLA 系列
LLM 系列
LLR 系列
警告/注意事项

GQM 系列温度补偿型 High Q 品名列表

(→ ■ 1.6×0.8mm)

T 最大值	额定 电压	温度特 性代号	静电容量	公差	品名		
0.9mm	100Vdc	COG	1.8pF	±0.1pF	GQM1885C2A1R8BB01#		
				±0.25pF	GQM1885C2A1R8CB01#		
			2.0pF	±0.1pF	GQM1885C2A2R0BB01#		
				±0.25pF	GQM1885C2A2R0CB01#		
			2.2pF	±0.1pF	GQM1885C2A2R2BB01#		
				±0.25pF	GQM1885C2A2R2CB01#		
			2.4pF	±0.1pF	GQM1885C2A2R4BB01#		
				±0.25pF	GQM1885C2A2R4CB01#		
			2.7pF	±0.1pF	GQM1885C2A2R7BB01#		
				±0.25pF	GQM1885C2A2R7CB01#		
			3.0pF	±0.1pF	GQM1885C2A3R0BB01#		
				±0.25pF	GQM1885C2A3R0CB01#		
			3.3pF	±0.1pF	GQM1885C2A3R3BB01#		
				±0.25pF	GQM1885C2A3R3CB01#		
			3.6pF	±0.1pF	GQM1885C2A3R6BB01#		
				±0.25pF	GQM1885C2A3R6CB01#		
			3.9pF	±0.1pF	GQM1885C2A3R9BB01#		
				±0.25pF	GQM1885C2A3R9CB01#		
			4.0pF	±0.1pF	GQM1885C2A4R0BB01#		
				±0.25pF	GQM1885C2A4R0CB01#		
			4.3pF	±0.1pF	GQM1885C2A4R3BB01#		
				±0.25pF	GQM1885C2A4R3CB01#		
			4.7pF	±0.1pF	GQM1885C2A4R7BB01#		
				±0.25pF	GQM1885C2A4R7CB01#		
			5.0pF	±0.1pF	GQM1885C2A5R0BB01#		
				±0.25pF	GQM1885C2A5R0CB01#		
			5.1pF	±0.25pF	GQM1885C2A5R1CB01#		
				±0.5pF	GQM1885C2A5R1DB01#		
			5.6pF	±0.25pF	GQM1885C2A5R6CB01#		
				±0.5pF	GQM1885C2A5R6DB01#		
			6.0pF	±0.25pF	GQM1885C2A6R0CB01#		
				±0.5pF	GQM1885C2A6R0DB01#		
			6.2pF	±0.25pF	GQM1885C2A6R2CB01#		
				±0.5pF	GQM1885C2A6R2DB01#		
			6.8pF	±0.25pF	GQM1885C2A6R8CB01#		
				±0.5pF	GQM1885C2A6R8DB01#		
			CK	1.0pF	±0.1pF	GQM1884C2A1R0BB01#	
					±0.25pF	GQM1884C2A1R0CB01#	
				1.1pF	±0.1pF	GQM1884C2A1R1BB01#	
					±0.25pF	GQM1884C2A1R1CB01#	
				1.2pF	±0.1pF	GQM1884C2A1R2BB01#	
					±0.25pF	GQM1884C2A1R2CB01#	
				1.3pF	±0.1pF	GQM1884C2A1R3BB01#	
					±0.25pF	GQM1884C2A1R3CB01#	
				1.5pF	±0.1pF	GQM1884C2A1R5BB01#	
					±0.25pF	GQM1884C2A1R5CB01#	
				1.6pF	±0.1pF	GQM1884C2A1R6BB01#	
					±0.25pF	GQM1884C2A1R6CB01#	
				1.8pF	±0.1pF	GQM1884C2A1R8BB01#	
					±0.25pF	GQM1884C2A1R8CB01#	
				2.0pF	±0.1pF	GQM1884C2A2R0BB01#	
					±0.25pF	GQM1884C2A2R0CB01#	
				CJ	2.2pF	±0.1pF	GQM1883C2A2R2BB01#
						±0.25pF	GQM1883C2A2R2CB01#

T 最大值	额定 电压	温度特 性代号	静电容量	公差	品名	
0.9mm	100Vdc	CJ	2.4pF	±0.1pF	GQM1883C2A2R4BB01#	
				±0.25pF	GQM1883C2A2R4CB01#	
			2.7pF	±0.1pF	GQM1883C2A2R7BB01#	
				±0.25pF	GQM1883C2A2R7CB01#	
			3.0pF	±0.1pF	GQM1883C2A3R0BB01#	
				±0.25pF	GQM1883C2A3R0CB01#	
			3.3pF	±0.1pF	GQM1883C2A3R3BB01#	
				±0.25pF	GQM1883C2A3R3CB01#	
			3.6pF	±0.1pF	GQM1883C2A3R6BB01#	
				±0.25pF	GQM1883C2A3R6CB01#	
			3.9pF	±0.1pF	GQM1883C2A3R9BB01#	
				±0.25pF	GQM1883C2A3R9CB01#	
			CH	4.0pF	±0.1pF	GQM1882C2A4R0BB01#
					±0.25pF	GQM1882C2A4R0CB01#
				4.3pF	±0.1pF	GQM1882C2A4R3BB01#
					±0.25pF	GQM1882C2A4R3CB01#
				4.7pF	±0.1pF	GQM1882C2A4R7BB01#
					±0.25pF	GQM1882C2A4R7CB01#
				5.0pF	±0.1pF	GQM1882C2A5R0BB01#
					±0.25pF	GQM1882C2A5R0CB01#
				5.1pF	±0.25pF	GQM1882C2A5R1CB01#
			±0.5pF		GQM1882C2A5R1DB01#	
			5.6pF	±0.25pF	GQM1882C2A5R6CB01#	
				±0.5pF	GQM1882C2A5R6DB01#	
			6.0pF	±0.25pF	GQM1882C2A6R0CB01#	
				±0.5pF	GQM1882C2A6R0DB01#	
			6.2pF	±0.25pF	GQM1882C2A6R2CB01#	
		±0.5pF		GQM1882C2A6R2DB01#		
		6.8pF	±0.25pF	GQM1882C2A6R8CB01#		
			±0.5pF	GQM1882C2A6R8DB01#		
		50Vdc	COG	7.0pF	±0.25pF	GQM1885C1H7R0CB01#
					±0.5pF	GQM1885C1H7R0DB01#
				7.5pF	±0.25pF	GQM1885C1H7R5CB01#
					±0.5pF	GQM1885C1H7R5DB01#
				8.0pF	±0.25pF	GQM1885C1H8R0CB01#
					±0.5pF	GQM1885C1H8R0DB01#
				8.2pF	±0.25pF	GQM1885C1H8R2CB01#
					±0.5pF	GQM1885C1H8R2DB01#
				9.0pF	±0.25pF	GQM1885C1H9R0CB01#
					±0.5pF	GQM1885C1H9R0DB01#
				9.1pF	±0.25pF	GQM1885C1H9R1CB01#
					±0.5pF	GQM1885C1H9R1DB01#
				10pF	±2%	GQM1885C1H100GB01#
					±5%	GQM1885C1H100JB01#
				11pF	±2%	GQM1885C1H110GB01#
					±5%	GQM1885C1H110JB01#
				12pF	±2%	GQM1885C1H120GB01#
					±5%	GQM1885C1H120JB01#
		13pF	±2%	GQM1885C1H130GB01#		
			±5%	GQM1885C1H130JB01#		
		15pF	±2%	GQM1885C1H150GB01#		
			±5%	GQM1885C1H150JB01#		
		16pF	±2%	GQM1885C1H160GB01#		
			±5%	GQM1885C1H160JB01#		

品名 # 表示包装规格代码。

GRM 系列
GJM 系列
GMA 系列
GMD 系列
GQM 系列
GRJ 系列
GR3 系列
KRM 系列
KR3 系列
LLA 系列
LLL 系列
LLM 系列
LLR 系列
警告 / 注意事項

GQM 系列温度补偿型 品名列表

(→ ■ 1.6×0.8mm)

T 最大值	额定 电压	温度特 性代号	静电容量	公差	品名			
0.9mm	50Vdc	C0G	18pF	±2%	GQM1885C1H180GB01#			
				±5%	GQM1885C1H180JB01#			
			20pF	±2%	GQM1885C1H200GB01#			
				±5%	GQM1885C1H200JB01#			
			22pF	±2%	GQM1885C1H220GB01#			
				±5%	GQM1885C1H220JB01#			
			24pF	±2%	GQM1885C1H240GB01#			
				±5%	GQM1885C1H240JB01#			
			27pF	±2%	GQM1885C1H270GB01#			
				±5%	GQM1885C1H270JB01#			
			30pF	±2%	GQM1885C1H300GB01#			
				±5%	GQM1885C1H300JB01#			
			33pF	±2%	GQM1885C1H330GB01#			
				±5%	GQM1885C1H330JB01#			
			36pF	±2%	GQM1885C1H360GB01#			
				±5%	GQM1885C1H360JB01#			
			39pF	±2%	GQM1885C1H390GB01#			
				±5%	GQM1885C1H390JB01#			
			43pF	±2%	GQM1885C1H430GB01#			
				±5%	GQM1885C1H430JB01#			
			47pF	±2%	GQM1885C1H470GB01#			
				±5%	GQM1885C1H470JB01#			
			51pF	±2%	GQM1885C1H510GB01#			
				±5%	GQM1885C1H510JB01#			
			56pF	±2%	GQM1885C1H560GB01#			
				±5%	GQM1885C1H560JB01#			
			62pF	±2%	GQM1885C1H620GB01#			
				±5%	GQM1885C1H620JB01#			
			68pF	±2%	GQM1885C1H680GB01#			
				±5%	GQM1885C1H680JB01#			
			75pF	±2%	GQM1885C1H750GB01#			
				±5%	GQM1885C1H750JB01#			
			82pF	±2%	GQM1885C1H820GB01#			
				±5%	GQM1885C1H820JB01#			
			91pF	±2%	GQM1885C1H910GB01#			
				±5%	GQM1885C1H910JB01#			
			100pF	±2%	GQM1885C1H101GB01#			
				±5%	GQM1885C1H101JB01#			
			CH	50Vdc	CH	7.0pF	±0.25pF	GQM1882C1H7R0CB01#
							±0.5pF	GQM1882C1H7R0DB01#
						7.5pF	±0.25pF	GQM1882C1H7R5CB01#
							±0.5pF	GQM1882C1H7R5DB01#
8.0pF	±0.25pF	GQM1882C1H8R0CB01#						
	±0.5pF	GQM1882C1H8R0DB01#						
8.2pF	±0.25pF	GQM1882C1H8R2CB01#						
	±0.5pF	GQM1882C1H8R2DB01#						
9.0pF	±0.25pF	GQM1882C1H9R0CB01#						
	±0.5pF	GQM1882C1H9R0DB01#						
9.1pF	±0.25pF	GQM1882C1H9R1CB01#						
	±0.5pF	GQM1882C1H9R1DB01#						
10pF	±2%	GQM1882C1H100GB01#						
	±5%	GQM1882C1H100JB01#						
11pF	±2%	GQM1882C1H110GB01#						
	±5%	GQM1882C1H110JB01#						

T 最大值	额定 电压	温度特 性代号	静电容量	公差	品名
0.9mm	50Vdc	CH	12pF	±2%	GQM1882C1H120GB01#
				±5%	GQM1882C1H120JB01#
			13pF	±2%	GQM1882C1H130GB01#
				±5%	GQM1882C1H130JB01#
			15pF	±2%	GQM1882C1H150GB01#
				±5%	GQM1882C1H150JB01#
			16pF	±2%	GQM1882C1H160GB01#
				±5%	GQM1882C1H160JB01#
			18pF	±2%	GQM1882C1H180GB01#
				±5%	GQM1882C1H180JB01#
			20pF	±2%	GQM1882C1H200GB01#
				±5%	GQM1882C1H200JB01#
			22pF	±2%	GQM1882C1H220GB01#
				±5%	GQM1882C1H220JB01#
			24pF	±2%	GQM1882C1H240GB01#
				±5%	GQM1882C1H240JB01#
			27pF	±2%	GQM1882C1H270GB01#
				±5%	GQM1882C1H270JB01#
			30pF	±2%	GQM1882C1H300GB01#
				±5%	GQM1882C1H300JB01#
			33pF	±2%	GQM1882C1H330GB01#
				±5%	GQM1882C1H330JB01#
			36pF	±2%	GQM1882C1H360GB01#
				±5%	GQM1882C1H360JB01#
			39pF	±2%	GQM1882C1H390GB01#
				±5%	GQM1882C1H390JB01#
			43pF	±2%	GQM1882C1H430GB01#
				±5%	GQM1882C1H430JB01#
			47pF	±2%	GQM1882C1H470GB01#
				±5%	GQM1882C1H470JB01#
			51pF	±2%	GQM1882C1H510GB01#
				±5%	GQM1882C1H510JB01#
			56pF	±2%	GQM1882C1H560GB01#
				±5%	GQM1882C1H560JB01#
			62pF	±2%	GQM1882C1H620GB01#
				±5%	GQM1882C1H620JB01#
			68pF	±2%	GQM1882C1H680GB01#
				±5%	GQM1882C1H680JB01#
			75pF	±2%	GQM1882C1H750GB01#
				±5%	GQM1882C1H750JB01#
			82pF	±2%	GQM1882C1H820GB01#
				±5%	GQM1882C1H820JB01#
91pF	±2%	GQM1882C1H910GB01#			
	±5%	GQM1882C1H910JB01#			
100pF	±2%	GQM1882C1H101GB01#			
	±5%	GQM1882C1H101JB01#			

■ 2.0×1.25mm

T 最大值	额定 电压	温度特 性代号	静电容量	公差	品名
0.95mm	100Vdc	C0G	1.0pF	±0.1pF	GQM2195C2A1R0BB01#
				±0.25pF	GQM2195C2A1R0CB01#
				±0.1pF	GQM2195C2A1R1BB01#

品名 # 表示包装规格代码。

GRM 系列
GJM 系列
GMA 系列
GMD 系列
GQM 系列
GRJ 系列
GR3 系列
KRM 系列
KR3 系列
LLA 系列
LLL 系列
LLM 系列
LLR 系列
警告/注意事项

QGM 系列温度补偿型 品名列表

(→ ■ 2.0×1.25mm)

T 最大值	额定 电压	温度特 性代号	静电容量	公差	品名
0.95mm	100Vdc	COG	1.1pF	±0.25pF	QGM2195C2A1R1CB01#
				±0.1pF	QGM2195C2A1R2BB01#
			1.2pF	±0.25pF	QGM2195C2A1R2CB01#
				±0.1pF	QGM2195C2A1R3BB01#
			1.3pF	±0.25pF	QGM2195C2A1R3CB01#
				±0.1pF	QGM2195C2A1R5BB01#
			1.5pF	±0.25pF	QGM2195C2A1R5CB01#
				±0.1pF	QGM2195C2A1R6BB01#
			1.6pF	±0.25pF	QGM2195C2A1R6CB01#
				±0.1pF	QGM2195C2A1R8BB01#
			1.8pF	±0.25pF	QGM2195C2A1R8CB01#
				±0.1pF	QGM2195C2A2R0BB01#
			2.0pF	±0.25pF	QGM2195C2A2R0CB01#
				±0.1pF	QGM2195C2A2R2BB01#
			2.2pF	±0.25pF	QGM2195C2A2R2CB01#
				±0.1pF	QGM2195C2A2R4BB01#
			2.4pF	±0.25pF	QGM2195C2A2R4CB01#
				±0.1pF	QGM2195C2A2R7BB01#
			2.7pF	±0.25pF	QGM2195C2A2R7CB01#
				±0.1pF	QGM2195C2A3R0BB01#
			3.0pF	±0.25pF	QGM2195C2A3R0CB01#
				±0.1pF	QGM2195C2A3R3BB01#
			3.3pF	±0.25pF	QGM2195C2A3R3CB01#
				±0.1pF	QGM2195C2A3R6BB01#
			3.6pF	±0.25pF	QGM2195C2A3R6CB01#
				±0.1pF	QGM2195C2A3R9BB01#
			3.9pF	±0.25pF	QGM2195C2A3R9CB01#
				±0.1pF	QGM2195C2A4R0BB01#
			4.0pF	±0.25pF	QGM2195C2A4R0CB01#
				±0.1pF	QGM2195C2A4R3BB01#
			4.3pF	±0.25pF	QGM2195C2A4R3CB01#
				±0.1pF	QGM2195C2A4R7BB01#
			4.7pF	±0.25pF	QGM2195C2A4R7CB01#
				±0.1pF	QGM2195C2A5R0BB01#
			5.0pF	±0.25pF	QGM2195C2A5R0CB01#
				±0.25pF	QGM2195C2A5R1CB01#
			5.1pF	±0.5pF	QGM2195C2A5R1DB01#
				±0.25pF	QGM2195C2A5R6CB01#
			5.6pF	±0.5pF	QGM2195C2A5R6DB01#
				±0.25pF	QGM2195C2A6R0CB01#
			6.0pF	±0.5pF	QGM2195C2A6R0DB01#
				±0.25pF	QGM2195C2A6R2CB01#
			6.2pF	±0.5pF	QGM2195C2A6R2DB01#
				±0.25pF	QGM2195C2A6R8CB01#
			6.8pF	±0.5pF	QGM2195C2A6R8DB01#
				±0.25pF	QGM2195C2A7R0CB01#
			7.0pF	±0.5pF	QGM2195C2A7R0DB01#
				±0.25pF	QGM2195C2A7R5CB01#
7.5pF	±0.5pF	QGM2195C2A7R5DB01#			
	±0.25pF	QGM2195C2A8R0CB01#			
8.0pF	±0.5pF	QGM2195C2A8R0DB01#			
	±0.25pF	QGM2195C2A8R2CB01#			
8.2pF	±0.5pF	QGM2195C2A8R2DB01#			
	±0.25pF	QGM2195C2A9R0CB01#			
9.0pF	±0.25pF	QGM2195C2A9R0CB01#			

T 最大值	额定 电压	温度特 性代号	静电容量	公差	品名	
0.95mm	100Vdc	COG	9.0pF	±0.5pF	QGM2195C2A9R0DB01#	
				±0.25pF	QGM2195C2A9R1CB01#	
			9.1pF	±0.5pF	QGM2195C2A9R1DB01#	
				±2%	QGM2195C2A100GB01#	
			10pF	±5%	QGM2195C2A100JB01#	
				±2%	QGM2195C2A110GB01#	
			11pF	±5%	QGM2195C2A110JB01#	
				±2%	QGM2195C2A120GB01#	
			12pF	±5%	QGM2195C2A120JB01#	
				±2%	QGM2195C2A130GB01#	
			13pF	±5%	QGM2195C2A130JB01#	
				±2%	QGM2195C2A150GB01#	
			15pF	±5%	QGM2195C2A150JB01#	
				±2%	QGM2195C2A160GB01#	
			16pF	±5%	QGM2195C2A160JB01#	
				±2%	QGM2195C2A180GB01#	
			18pF	±5%	QGM2195C2A180JB01#	
				CK	1.0pF	±0.1pF
			±0.25pF			QGM2194C2A1R0CB01#
			1.1pF		±0.1pF	QGM2194C2A1R1BB01#
					±0.25pF	QGM2194C2A1R1CB01#
			1.2pF		±0.1pF	QGM2194C2A1R2BB01#
					±0.25pF	QGM2194C2A1R2CB01#
			1.3pF		±0.1pF	QGM2194C2A1R3BB01#
		±0.25pF			QGM2194C2A1R3CB01#	
		1.5pF	±0.1pF		QGM2194C2A1R5BB01#	
			±0.25pF		QGM2194C2A1R5CB01#	
		1.6pF	±0.1pF		QGM2194C2A1R6BB01#	
			±0.25pF		QGM2194C2A1R6CB01#	
		1.8pF	±0.1pF	QGM2194C2A1R8BB01#		
			±0.25pF	QGM2194C2A1R8CB01#		
		2.0pF	±0.1pF	QGM2194C2A2R0BB01#		
			±0.25pF	QGM2194C2A2R0CB01#		
		2.2pF	±0.1pF	QGM2193C2A2R2BB01#		
			±0.25pF	QGM2193C2A2R2CB01#		
		2.4pF	±0.1pF	QGM2193C2A2R4BB01#		
			±0.25pF	QGM2193C2A2R4CB01#		
		2.7pF	±0.1pF	QGM2193C2A2R7BB01#		
			±0.25pF	QGM2193C2A2R7CB01#		
		3.0pF	±0.1pF	QGM2193C2A3R0BB01#		
			±0.25pF	QGM2193C2A3R0CB01#		
		3.3pF	±0.1pF	QGM2193C2A3R3BB01#		
			±0.25pF	QGM2193C2A3R3CB01#		
		3.6pF	±0.1pF	QGM2193C2A3R6BB01#		
			±0.25pF	QGM2193C2A3R6CB01#		
		3.9pF	±0.1pF	QGM2193C2A3R9BB01#		
			±0.25pF	QGM2193C2A3R9CB01#		
		4.0pF	±0.1pF	QGM2192C2A4R0BB01#		
±0.25pF	QGM2192C2A4R0CB01#					
4.3pF	±0.1pF	QGM2192C2A4R3BB01#				
	±0.25pF	QGM2192C2A4R3CB01#				
4.7pF	±0.1pF	QGM2192C2A4R7BB01#				
	±0.25pF	QGM2192C2A4R7CB01#				
5.0pF	±0.1pF	QGM2192C2A5R0BB01#				
	±0.25pF	QGM2192C2A5R0CB01#				
5.1pF	±0.1pF	QGM2192C2A5R1BB01#				
	±0.25pF	QGM2192C2A5R1CB01#				
5.6pF	±0.1pF	QGM2192C2A5R6BB01#				
	±0.25pF	QGM2192C2A5R6CB01#				
6.0pF	±0.1pF	QGM2192C2A6R0BB01#				
	±0.25pF	QGM2192C2A6R0CB01#				
6.2pF	±0.1pF	QGM2192C2A6R2BB01#				
	±0.25pF	QGM2192C2A6R2CB01#				
6.8pF	±0.1pF	QGM2192C2A6R8BB01#				
	±0.25pF	QGM2192C2A6R8CB01#				
7.0pF	±0.1pF	QGM2192C2A7R0BB01#				
	±0.25pF	QGM2192C2A7R0CB01#				
7.5pF	±0.1pF	QGM2192C2A7R5BB01#				
	±0.25pF	QGM2192C2A7R5CB01#				
8.0pF	±0.1pF	QGM2192C2A8R0BB01#				
	±0.25pF	QGM2192C2A8R0CB01#				
8.2pF	±0.1pF	QGM2192C2A8R2BB01#				
	±0.25pF	QGM2192C2A8R2CB01#				
9.0pF	±0.1pF	QGM2192C2A9R0BB01#				

品名 # 表示包装规格代码。

- GRM 系列
- GJM 系列
- GMA 系列
- GMD 系列
- QGM 系列**
- GRJ 系列
- GR3 系列
- KRM 系列
- KR3 系列
- LJA 系列
- LLL 系列
- LLM 系列
- LLR 系列
- 警告 / 注意事項

GQM 系列温度补偿型 品名列表

(→ ■ 2.0×1.25mm)

T 最大值	额定 电压	温度特 性代号	静电容量	公差	品名		
0.95mm	100Vdc	CH	5.0pF	±0.25pF	GQM2192C2A5R0CB01#		
			5.1pF	±0.25pF	GQM2192C2A5R1CB01#		
				±0.5pF	GQM2192C2A5R1DB01#		
			5.6pF	±0.25pF	GQM2192C2A5R6CB01#		
				±0.5pF	GQM2192C2A5R6DB01#		
			6.0pF	±0.25pF	GQM2192C2A6R0CB01#		
				±0.5pF	GQM2192C2A6R0DB01#		
			6.2pF	±0.25pF	GQM2192C2A6R2CB01#		
				±0.5pF	GQM2192C2A6R2DB01#		
			6.8pF	±0.25pF	GQM2192C2A6R8CB01#		
				±0.5pF	GQM2192C2A6R8DB01#		
			7.0pF	±0.25pF	GQM2192C2A7R0CB01#		
				±0.5pF	GQM2192C2A7R0DB01#		
			7.5pF	±0.25pF	GQM2192C2A7R5CB01#		
				±0.5pF	GQM2192C2A7R5DB01#		
			8.0pF	±0.25pF	GQM2192C2A8R0CB01#		
				±0.5pF	GQM2192C2A8R0DB01#		
			8.2pF	±0.25pF	GQM2192C2A8R2CB01#		
				±0.5pF	GQM2192C2A8R2DB01#		
			9.0pF	±0.25pF	GQM2192C2A9R0CB01#		
				±0.5pF	GQM2192C2A9R0DB01#		
			9.1pF	±0.25pF	GQM2192C2A9R1CB01#		
				±0.5pF	GQM2192C2A9R1DB01#		
			10pF	±2%	GQM2192C2A100GB01#		
				±5%	GQM2192C2A100JB01#		
			11pF	±2%	GQM2192C2A110GB01#		
				±5%	GQM2192C2A110JB01#		
			12pF	±2%	GQM2192C2A120GB01#		
				±5%	GQM2192C2A120JB01#		
			13pF	±2%	GQM2192C2A130GB01#		
				±5%	GQM2192C2A130JB01#		
			15pF	±2%	GQM2192C2A150GB01#		
				±5%	GQM2192C2A150JB01#		
			16pF	±2%	GQM2192C2A160GB01#		
				±5%	GQM2192C2A160JB01#		
			18pF	±2%	GQM2192C2A180GB01#		
				±5%	GQM2192C2A180JB01#		
			50Vdc	COG	20pF	±2%	GQM2195C1H200GB01#
						±5%	GQM2195C1H200JB01#
					22pF	±2%	GQM2195C1H220GB01#
						±5%	GQM2195C1H220JB01#
					24pF	±2%	GQM2195C1H240GB01#
±5%	GQM2195C1H240JB01#						
27pF	±2%	GQM2195C1H270GB01#					
	±5%	GQM2195C1H270JB01#					
30pF	±2%	GQM2195C1H300GB01#					
	±5%	GQM2195C1H300JB01#					
33pF	±2%	GQM2195C1H330GB01#					
	±5%	GQM2195C1H330JB01#					
36pF	±2%	GQM2195C1H360GB01#					
	±5%	GQM2195C1H360JB01#					
39pF	±2%	GQM2195C1H390GB01#					
	±5%	GQM2195C1H390JB01#					
43pF	±2%	GQM2195C1H430GB01#					
	±5%	GQM2195C1H430JB01#					

T 最大值	额定 电压	温度特 性代号	静电容量	公差	品名		
0.95mm	50Vdc	COG	43pF	±5%	GQM2195C1H430JB01#		
			47pF	±2%	GQM2195C1H470GB01#		
				±5%	GQM2195C1H470JB01#		
			51pF	±2%	GQM2195C1H510GB01#		
				±5%	GQM2195C1H510JB01#		
			56pF	±2%	GQM2195C1H560GB01#		
				±5%	GQM2195C1H560JB01#		
			62pF	±2%	GQM2195C1H620GB01#		
				±5%	GQM2195C1H620JB01#		
			68pF	±2%	GQM2195C1H680GB01#		
				±5%	GQM2195C1H680JB01#		
			75pF	±2%	GQM2195C1H750GB01#		
				±5%	GQM2195C1H750JB01#		
			82pF	±2%	GQM2195C1H820GB01#		
				±5%	GQM2195C1H820JB01#		
			91pF	±2%	GQM2195C1H910GB01#		
				±5%	GQM2195C1H910JB01#		
			100pF	±2%	GQM2195C1H101GB01#		
				±5%	GQM2195C1H101JB01#		
			CH	CH	20pF	±2%	GQM2192C1H200GB01#
						±5%	GQM2192C1H200JB01#
		22pF			±2%	GQM2192C1H220GB01#	
					±5%	GQM2192C1H220JB01#	
		24pF			±2%	GQM2192C1H240GB01#	
					±5%	GQM2192C1H240JB01#	
		27pF			±2%	GQM2192C1H270GB01#	
					±5%	GQM2192C1H270JB01#	
		30pF			±2%	GQM2192C1H300GB01#	
					±5%	GQM2192C1H300JB01#	
		33pF			±2%	GQM2192C1H330GB01#	
					±5%	GQM2192C1H330JB01#	
		36pF			±2%	GQM2192C1H360GB01#	
					±5%	GQM2192C1H360JB01#	
		39pF			±2%	GQM2192C1H390GB01#	
					±5%	GQM2192C1H390JB01#	
		43pF			±2%	GQM2192C1H430GB01#	
					±5%	GQM2192C1H430JB01#	
		47pF			±2%	GQM2192C1H470GB01#	
			±5%	GQM2192C1H470JB01#			
		51pF	±2%	GQM2192C1H510GB01#			
			±5%	GQM2192C1H510JB01#			
		56pF	±2%	GQM2192C1H560GB01#			
±5%	GQM2192C1H560JB01#						
62pF	±2%	GQM2192C1H620GB01#					
	±5%	GQM2192C1H620JB01#					
68pF	±2%	GQM2192C1H680GB01#					
	±5%	GQM2192C1H680JB01#					
75pF	±2%	GQM2192C1H750GB01#					
	±5%	GQM2192C1H750JB01#					
82pF	±2%	GQM2192C1H820GB01#					
	±5%	GQM2192C1H820JB01#					
91pF	±2%	GQM2192C1H910GB01#					
	±5%	GQM2192C1H910JB01#					
100pF	±2%	GQM2192C1H101GB01#					
	±5%	GQM2192C1H101JB01#					

品名 # 表示包装规格代码。

GRM 系列
GJM 系列
GMA 系列
GMD 系列
GQM 系列
GRJ 系列
GR3 系列
KRM 系列
KR3 系列
LLA 系列
LLL 系列
LLM 系列
LLR 系列
警告/注意事项

GQM 系列温度补偿型 High Q 品名列表

(→ ■ 2.0×1.25mm)

T 最大值	额定 电压	温度特 性代号	静电容量	公差	品名
0.95mm	50Vdc	CH	100pF	±5%	GQM2192C1H101JB01#
1.0mm	250Vdc	COG	1.0pF	±0.1pF	GQM2195C2E1R0BB12#
				±0.25pF	GQM2195C2E1R0CB12#
			1.1pF	±0.1pF	GQM2195C2E1R1BB12#
				±0.25pF	GQM2195C2E1R1CB12#
			1.2pF	±0.1pF	GQM2195C2E1R2BB12#
				±0.25pF	GQM2195C2E1R2CB12#
			1.3pF	±0.1pF	GQM2195C2E1R3BB12#
				±0.25pF	GQM2195C2E1R3CB12#
			1.5pF	±0.1pF	GQM2195C2E1R5BB12#
				±0.25pF	GQM2195C2E1R5CB12#
			1.6pF	±0.1pF	GQM2195C2E1R6BB12#
				±0.25pF	GQM2195C2E1R6CB12#
			1.8pF	±0.1pF	GQM2195C2E1R8BB12#
				±0.25pF	GQM2195C2E1R8CB12#
			2.0pF	±0.1pF	GQM2195C2E2R0BB12#
				±0.25pF	GQM2195C2E2R0CB12#
			2.2pF	±0.1pF	GQM2195C2E2R2BB12#
				±0.25pF	GQM2195C2E2R2CB12#
			2.4pF	±0.1pF	GQM2195C2E2R4BB12#
				±0.25pF	GQM2195C2E2R4CB12#
			2.7pF	±0.1pF	GQM2195C2E2R7BB12#
				±0.25pF	GQM2195C2E2R7CB12#
			3.0pF	±0.1pF	GQM2195C2E3R0BB12#
				±0.25pF	GQM2195C2E3R0CB12#
			3.3pF	±0.1pF	GQM2195C2E3R3BB12#
				±0.25pF	GQM2195C2E3R3CB12#
			3.6pF	±0.1pF	GQM2195C2E3R6BB12#
				±0.25pF	GQM2195C2E3R6CB12#
			3.9pF	±0.1pF	GQM2195C2E3R9BB12#
				±0.25pF	GQM2195C2E3R9CB12#
			4.0pF	±0.1pF	GQM2195C2E4R0BB12#
				±0.25pF	GQM2195C2E4R0CB12#
			4.3pF	±0.1pF	GQM2195C2E4R3BB12#
				±0.25pF	GQM2195C2E4R3CB12#
			4.7pF	±0.1pF	GQM2195C2E4R7BB12#
				±0.25pF	GQM2195C2E4R7CB12#
			5.0pF	±0.1pF	GQM2195C2E5R0BB12#
				±0.25pF	GQM2195C2E5R0CB12#
			5.1pF	±0.25pF	GQM2195C2E5R1CB12#
				±0.5pF	GQM2195C2E5R1DB12#
5.6pF	±0.25pF	GQM2195C2E5R6CB12#			
	±0.5pF	GQM2195C2E5R6DB12#			
6.0pF	±0.25pF	GQM2195C2E6R0CB12#			
	±0.5pF	GQM2195C2E6R0DB12#			
6.2pF	±0.25pF	GQM2195C2E6R2CB12#			
	±0.5pF	GQM2195C2E6R2DB12#			
6.8pF	±0.25pF	GQM2195C2E6R8CB12#			
	±0.5pF	GQM2195C2E6R8DB12#			
7.0pF	±0.25pF	GQM2195C2E7R0CB12#			
	±0.5pF	GQM2195C2E7R0DB12#			
7.5pF	±0.25pF	GQM2195C2E7R5CB12#			
	±0.5pF	GQM2195C2E7R5DB12#			
8.0pF	±0.25pF	GQM2195C2E8R0CB12#			

T 最大值	额定 电压	温度特 性代号	静电容量	公差	品名
1.0mm	250Vdc	COG	8.0pF	±0.5pF	GQM2195C2E8R0DB12#
			8.2pF	±0.25pF	GQM2195C2E8R2CB12#
				±0.5pF	GQM2195C2E8R2DB12#
			9.0pF	±0.25pF	GQM2195C2E9R0CB12#
				±0.5pF	GQM2195C2E9R0DB12#
			9.1pF	±0.25pF	GQM2195C2E9R1CB12#
				±0.5pF	GQM2195C2E9R1DB12#
			10pF	±2%	GQM2195C2E100GB12#
				±5%	GQM2195C2E100JB12#
			11pF	±2%	GQM2195C2E110GB12#
				±5%	GQM2195C2E110JB12#
			12pF	±2%	GQM2195C2E120GB12#
				±5%	GQM2195C2E120JB12#
			13pF	±2%	GQM2195C2E130GB12#
				±5%	GQM2195C2E130JB12#
			15pF	±2%	GQM2195C2E150GB12#
				±5%	GQM2195C2E150JB12#
			16pF	±2%	GQM2195C2E160GB12#
				±5%	GQM2195C2E160JB12#
			18pF	±2%	GQM2195C2E180GB12#
				±5%	GQM2195C2E180JB12#
			20pF	±2%	GQM2195C2E200GB12#
				±5%	GQM2195C2E200JB12#
			22pF	±2%	GQM2195C2E220GB12#
				±5%	GQM2195C2E220JB12#
			24pF	±2%	GQM2195C2E240GB12#
				±5%	GQM2195C2E240JB12#
			27pF	±2%	GQM2195C2E270GB12#
				±5%	GQM2195C2E270JB12#
			30pF	±2%	GQM2195C2E300GB12#
±5%	GQM2195C2E300JB12#				
33pF	±2%	GQM2195C2E330GB12#			
	±5%	GQM2195C2E330JB12#			
36pF	±2%	GQM2195C2E360GB12#			
	±5%	GQM2195C2E360JB12#			
39pF	±2%	GQM2195C2E390GB12#			
	±5%	GQM2195C2E390JB12#			
43pF	±2%	GQM2195C2E430GB12#			
	±5%	GQM2195C2E430JB12#			
47pF	±2%	GQM2195C2E470GB12#			
	±5%	GQM2195C2E470JB12#			
51pF	±2%	GQM2195C2E510GB12#			
	±5%	GQM2195C2E510JB12#			
56pF	±2%	GQM2195C2E560GB12#			
	±5%	GQM2195C2E560JB12#			
62pF	±2%	GQM2195C2E620GB12#			
	±5%	GQM2195C2E620JB12#			
68pF	±2%	GQM2195C2E680GB12#			
	±5%	GQM2195C2E680JB12#			
75pF	±2%	GQM2195C2E750GB12#			
	±5%	GQM2195C2E750JB12#			
82pF	±2%	GQM2195C2E820GB12#			
	±5%	GQM2195C2E820JB12#			
91pF	±2%	GQM2195C2E910GB12#			

品名 # 表示包装规格代码。

GRM 系列
GJM 系列
GMA 系列
GMD 系列
GQM 系列
GRJ 系列
GR3 系列
KRM 系列
KR3 系列
LLA 系列
LLL 系列
LLM 系列
LLR 系列
警告 / 注意事項

GQM 系列温度补偿型 品名列表

(→ ■ 2.0×1.25mm)

T 最大值	额定 电压	温度特 性代号	静电容量	公差	品名
1.0mm	250Vdc	C0G	91pF	±5%	GQM2195C2E910JB12#
			100pF	±2%	GQM2195C2E101GB12#
				±5%	GQM2195C2E101JB12#

T 最大值	额定 电压	温度特 性代号	静电容量	公差	品名
1.35mm	500Vdc	C0G	6.8pF	±0.25pF	GQM22M5C2H6R8CB01#
				±0.5pF	GQM22M5C2H6R8DB01#
			7.0pF	±0.25pF	GQM22M5C2H7R0CB01#
				±0.5pF	GQM22M5C2H7R0DB01#
			7.5pF	±0.25pF	GQM22M5C2H7R5CB01#
				±0.5pF	GQM22M5C2H7R5DB01#
			8.0pF	±0.25pF	GQM22M5C2H8R0CB01#
				±0.5pF	GQM22M5C2H8R0DB01#
			8.2pF	±0.25pF	GQM22M5C2H8R2CB01#
				±0.5pF	GQM22M5C2H8R2DB01#
			9.0pF	±0.25pF	GQM22M5C2H9R0CB01#
				±0.5pF	GQM22M5C2H9R0DB01#
			9.1pF	±0.25pF	GQM22M5C2H9R1CB01#
				±0.5pF	GQM22M5C2H9R1DB01#
			10pF	±2%	GQM22M5C2H100GB01#
				±5%	GQM22M5C2H100JB01#
			11pF	±2%	GQM22M5C2H110GB01#
				±5%	GQM22M5C2H110JB01#
			12pF	±2%	GQM22M5C2H120GB01#
				±5%	GQM22M5C2H120JB01#
			13pF	±2%	GQM22M5C2H130GB01#
				±5%	GQM22M5C2H130JB01#
			15pF	±2%	GQM22M5C2H150GB01#
				±5%	GQM22M5C2H150JB01#
			16pF	±2%	GQM22M5C2H160GB01#
±5%	GQM22M5C2H160JB01#				
18pF	±2%	GQM22M5C2H180GB01#			
	±5%	GQM22M5C2H180JB01#			
20pF	±2%	GQM22M5C2H200GB01#			
	±5%	GQM22M5C2H200JB01#			
22pF	±2%	GQM22M5C2H220GB01#			
	±5%	GQM22M5C2H220JB01#			
24pF	±2%	GQM22M5C2H240GB01#			
	±5%	GQM22M5C2H240JB01#			
27pF	±2%	GQM22M5C2H270GB01#			
	±5%	GQM22M5C2H270JB01#			
30pF	±2%	GQM22M5C2H300GB01#			
	±5%	GQM22M5C2H300JB01#			
33pF	±2%	GQM22M5C2H330GB01#			
	±5%	GQM22M5C2H330JB01#			
36pF	±2%	GQM22M5C2H360GB01#			
	±5%	GQM22M5C2H360JB01#			
39pF	±2%	GQM22M5C2H390GB01#			
	±5%	GQM22M5C2H390JB01#			
43pF	±2%	GQM22M5C2H430GB01#			
	±5%	GQM22M5C2H430JB01#			
47pF	±2%	GQM22M5C2H470GB01#			
	±5%	GQM22M5C2H470JB01#			
51pF	±2%	GQM22M5C2H510GB01#			
	±5%	GQM22M5C2H510JB01#			
56pF	±2%	GQM22M5C2H560GB01#			
	±5%	GQM22M5C2H560JB01#			
62pF	±2%	GQM22M5C2H620GB01#			
	±5%	GQM22M5C2H620JB01#			

■ 2.8×2.8mm

T 最大值	额定 电压	温度特 性代号	静电容量	公差	品名
1.35mm	500Vdc	C0G	1.0pF	±0.1pF	GQM22M5C2H1R0BB01#
				±0.25pF	GQM22M5C2H1R0CB01#
			1.1pF	±0.1pF	GQM22M5C2H1R1BB01#
				±0.25pF	GQM22M5C2H1R1CB01#
			1.2pF	±0.1pF	GQM22M5C2H1R2BB01#
				±0.25pF	GQM22M5C2H1R2CB01#
			1.3pF	±0.1pF	GQM22M5C2H1R3BB01#
				±0.25pF	GQM22M5C2H1R3CB01#
			1.5pF	±0.1pF	GQM22M5C2H1R5BB01#
				±0.25pF	GQM22M5C2H1R5CB01#
			1.6pF	±0.1pF	GQM22M5C2H1R6BB01#
				±0.25pF	GQM22M5C2H1R6CB01#
			1.8pF	±0.1pF	GQM22M5C2H1R8BB01#
				±0.25pF	GQM22M5C2H1R8CB01#
			2.0pF	±0.1pF	GQM22M5C2H2R0BB01#
				±0.25pF	GQM22M5C2H2R0CB01#
			2.2pF	±0.1pF	GQM22M5C2H2R2BB01#
				±0.25pF	GQM22M5C2H2R2CB01#
			2.4pF	±0.1pF	GQM22M5C2H2R4BB01#
				±0.25pF	GQM22M5C2H2R4CB01#
			2.7pF	±0.1pF	GQM22M5C2H2R7BB01#
				±0.25pF	GQM22M5C2H2R7CB01#
			3.0pF	±0.1pF	GQM22M5C2H3R0BB01#
				±0.25pF	GQM22M5C2H3R0CB01#
			3.3pF	±0.1pF	GQM22M5C2H3R3BB01#
				±0.25pF	GQM22M5C2H3R3CB01#
			3.6pF	±0.1pF	GQM22M5C2H3R6BB01#
				±0.25pF	GQM22M5C2H3R6CB01#
			3.9pF	±0.1pF	GQM22M5C2H3R9BB01#
				±0.25pF	GQM22M5C2H3R9CB01#
			4.0pF	±0.1pF	GQM22M5C2H4R0BB01#
				±0.25pF	GQM22M5C2H4R0CB01#
			4.3pF	±0.1pF	GQM22M5C2H4R3BB01#
				±0.25pF	GQM22M5C2H4R3CB01#
			4.7pF	±0.1pF	GQM22M5C2H4R7BB01#
				±0.25pF	GQM22M5C2H4R7CB01#
			5.0pF	±0.1pF	GQM22M5C2H5R0BB01#
				±0.25pF	GQM22M5C2H5R0CB01#
			5.1pF	±0.25pF	GQM22M5C2H5R1CB01#
				±0.5pF	GQM22M5C2H5R1DB01#
			5.6pF	±0.25pF	GQM22M5C2H5R6CB01#
				±0.5pF	GQM22M5C2H5R6DB01#
			6.0pF	±0.25pF	GQM22M5C2H6R0CB01#
				±0.5pF	GQM22M5C2H6R0DB01#
			6.2pF	±0.25pF	GQM22M5C2H6R2CB01#
				±0.5pF	GQM22M5C2H6R2DB01#

品名 # 表示包装规格代码。

GRM 系列
GJM 系列
GMA 系列
GMD 系列
GQM 系列
GRJ 系列
GR3 系列
KRM 系列
KR3 系列
LLA 系列
LLL 系列
LLM 系列
LLR 系列
警告/注意事项

GRM 系列

GJM 系列

GMA 系列

GMD 系列

GQM 系列

GRJ 系列

GR3 系列

KRM 系列

KR3 系列

L1A 系列

L1L 系列

L1M 系列

L1R 系列

警告 / 注意事项

GQM 系列温度补偿型 **High Q** 品名列表

(→ ■ 2.8×2.8mm)

T 最大值	额定 电压	温度特 性代号	静电容量	公差	品名
1.35mm	500Vdc	C0G	68pF	±2%	GQM22M5C2H680GB01#
				±5%	GQM22M5C2H680JB01#
			75pF	±2%	GQM22M5C2H750GB01#
				±5%	GQM22M5C2H750JB01#
			82pF	±2%	GQM22M5C2H820GB01#
				±5%	GQM22M5C2H820JB01#
			91pF	±2%	GQM22M5C2H910GB01#
				±5%	GQM22M5C2H910JB01#
			100pF	±2%	GQM22M5C2H101GB01#
				±5%	GQM22M5C2H101JB01#

www.tocosc.com

品名 # 表示包装规格代码。

树脂外部电极型

GRJ 系列



裂纹
偏转

树脂外部电极防止电路板安装后弯曲应力造成的破裂出现!

特点

① 树脂外部电极抑制电路板弯曲所造成的破裂。

外部电极的树脂可释放应力，抑制陶瓷元件的破裂产生。

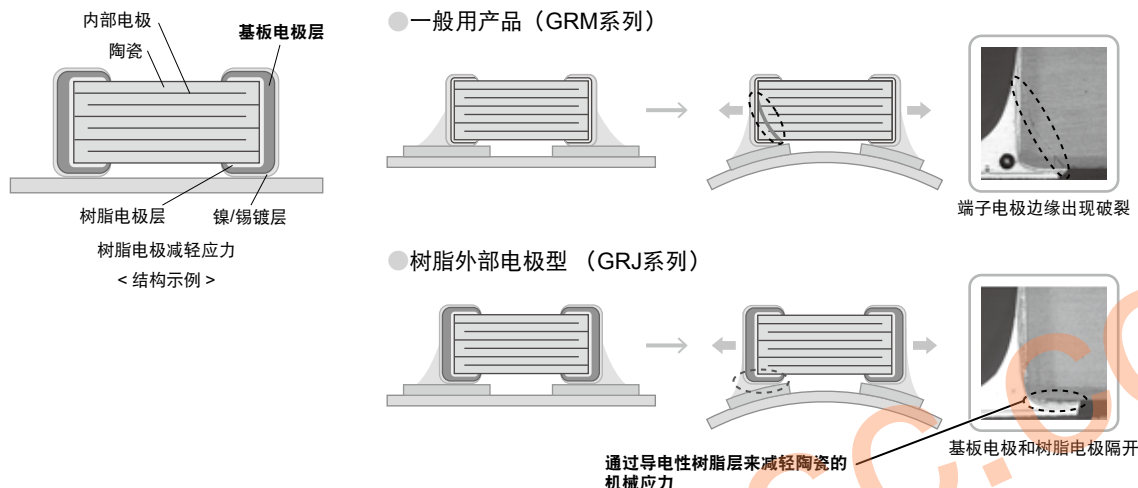

② 抑制了电路板安装时由弯曲应力造成的破裂产生等。

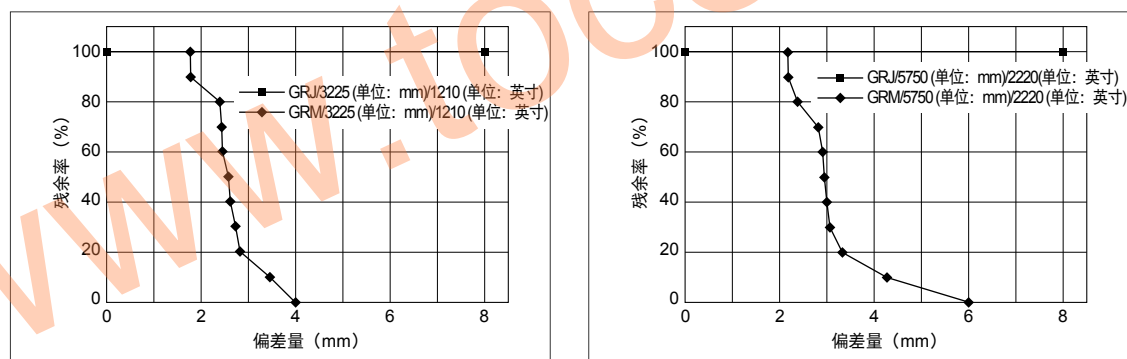

由于测量仪器的规格不同，可进行的测量值达 8mm。

③ 施加有热应力、振动和冲击的用电设备和工业电子设备的理想选择。

规格

尺寸	2.0×1.25mm 到 5.7×5.0mm
额定电压	DC6.3V 到 1kV
静电容量	470pF 到 47μF
主要应用	用电设备&工业电子设备

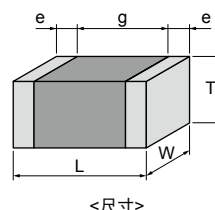

本目录仅列出了部分产品系列。
 详情请参阅村田网站中的电容器检索工具。

GRM 系列
GJM 系列
GMA 系列
GMD 系列
GQM 系列
GRJ 系列
GR3 系列
KRM 系列
KR3 系列
LLA 系列
LLL 系列
LLM 系列
LLR 系列
警告/注意事项

△注 · 本PDF产品目录是从株式会社村田制作所网站中下载的。规格若有变更，或若其中产品停产，恕不另行通知。请在订购之前向我公司销售代表或产品工程师查询。
· 本PDF产品目录所记载的产品规格，因受篇幅的限制，只提供了主要产品资料。在您订购前，必须确认规格表内容，或者互换协商定案图。

GRJ 系列高介电常数型 品名列表

■ 2.0×1.25mm

T 最大值	额定 电压	温度特 性代号	静电容量	公差	品名
1.0mm	250Vdc	X7R	1000pF	±10%	GRJ21AR72E102KWJ1#
			1500pF	±10%	GRJ21AR72E152KWJ1#
			2200pF	±10%	GRJ21AR72E222KWJ1#
			3300pF	±10%	GRJ21AR72E332KWJ1#
			4700pF	±10%	GRJ21AR72E472KWJ1#
			6800pF	±10%	GRJ21AR72E682KWJ1#
1.45mm	250Vdc	X7R	10000pF	±10%	GRJ21BR72E103KWJ3#
			15000pF	±10%	GRJ21BR72E153KWJ3#
			22000pF	±10%	GRJ21BR72E223KWJ3#

■ 3.2×1.6mm

T 最大值	额定 电压	温度特 性代号	静电容量	公差	品名			
1.25mm	1000Vdc	X7R	470pF	±10%	GRJ31BR73A471KWJ1#			
			680pF	±10%	GRJ31BR73A681KWJ1#			
			1000pF	±10%	GRJ31BR73A102KWJ1#			
			1500pF	±10%	GRJ31BR73A152KWJ1#			
			2200pF	±10%	GRJ31BR73A222KWJ1#			
			3300pF	±10%	GRJ31BR73A332KWJ1#			
			4700pF	±10%	GRJ31BR73A472KWJ1#			
		630Vdc	X7R	1000pF	±10%	GRJ31BR72J102KWJ1#		
				1500pF	±10%	GRJ31BR72J152KWJ1#		
				2200pF	±10%	GRJ31BR72J222KWJ1#		
	630Vdc	X7R	3300pF	±10%	GRJ31BR72J332KWJ1#			
			4700pF	±10%	GRJ31BR72J472KWJ1#			
			6800pF	±10%	GRJ31BR72J682KWJ1#			
			10000pF	±10%	GRJ31BR72J103KWJ1#			
			250Vdc	X7R	15000pF	±10%	GRJ31BR72E153KWJ1#	
					22000pF	±10%	GRJ31BR72E223KWJ1#	
					68000pF	±10%	GRJ31BR72E683KWJ1#	
			1.8mm	1000Vdc	X7R	6800pF	±10%	GRJ31CR73A682KWJ3#
						10000pF	±10%	GRJ31CR73A103KWJ3#
				630Vdc	X7R	15000pF	±10%	GRJ31CR72J153KWJ3#
22000pF	±10%	GRJ31CR72J223KWJ3#						
250Vdc	X7R	33000pF				±10%	GRJ31CR72E333KWJ3#	
		47000pF				±10%	GRJ31CR72E473KWJ3#	
			0.10μF	±10%	GRJ31CR72E104KWJ3#			

■ 3.2×2.5mm

T 最大值	额定 电压	温度特 性代号	静电容量	公差	品名
1.5mm	1000Vdc	X7R	6800pF	±10%	GRJ32QR73A682KWJ1#
			10000pF	±10%	GRJ32QR73A103KWJ1#
	630Vdc	X7R	22000pF	±10%	GRJ32QR72J223KWJ1#
			250Vdc	X7R	68000pF
			0.15μF		±10%
2.0mm	1000Vdc	X7R	15000pF	±10%	GRJ32DR73A153KWJ1#
			22000pF	±10%	GRJ32DR73A223KWJ1#
	630Vdc	X7R	33000pF	±10%	GRJ32DR72J333KWJ1#
			47000pF	±10%	GRJ32DR72J473KWJ1#

T 最大值	额定 电压	温度特 性代号	静电容量	公差	品名
2.0mm	250Vdc	X7R	0.10μF	±10%	GRJ32DR72E104KWJ1#
			0.22μF	±10%	GRJ32DR72E224KWJ1#
2.3mm	100Vdc	X7R	2.2μF	±10%	GRJ32DR72A225KE11#
				±20%	GRJ32DR72A225ME11#
2.8mm	50Vdc	X7R	4.7μF	±10%	GRJ32ER71H475KE11#
				±20%	GRJ32ER71H475ME11#
				X7S	10μF
	±20%	GRJ32EC71H106ME11#			
	25Vdc	X7R	10μF	±10%	GRJ32ER71E106KE11#
				±20%	GRJ32ER71E106ME11#
16Vdc	X7R	22μF	±10%	GRJ32ER71C226KE11#	
			±20%	GRJ32ER71C226ME11#	
10Vdc	X7R	22μF	±10%	GRJ32ER71A226KE11#	
			±20%	GRJ32ER71A226ME11#	
6.3Vdc	X7R	47μF	±10%	GRJ32ER70J476KE11#	
			±20%	GRJ32ER70J476ME11#	

■ 4.5×3.2mm

T 最大值	额定 电压	温度特 性代号	静电容量	公差	品名
1.5mm	630Vdc	X7R	68000pF	±10%	GRJ43QR72J683KWJ1#
	250Vdc	X7R	0.15μF	±10%	GRJ43QR72E154KWJ1#
2.0mm	1000Vdc	X7R	33000pF	±10%	GRJ43DR73A333KWJ1#
			47000pF	±10%	GRJ43DR73A473KWJ1#
	630Vdc	X7R	0.10μF	±10%	GRJ43DR72J104KWJ1#
			250Vdc	X7R	0.22μF
		0.33μF	±10%		GRJ43DR72E334KWJ1#
			0.47μF	±10%	GRJ43DR72E474KWJ1#

■ 5.7×5.0mm

T 最大值	额定 电压	温度特 性代号	静电容量	公差	品名
2.0mm	1000Vdc	X7R	68000pF	±10%	GRJ55DR73A683KWJ1#
			0.10μF	±10%	GRJ55DR73A104KWJ1#
	630Vdc	X7R	0.15μF	±10%	GRJ55DR72J154KWJ1#
			0.22μF	±10%	GRJ55DR72J224KWJ1#
	250Vdc	X7R	0.33μF	±10%	GRJ55DR72E334KWJ1#
			0.47μF	±10%	GRJ55DR72E474KWJ1#
			0.68μF	±10%	GRJ55DR72E684KWJ1#
			1.0μF	±10%	GRJ55DR72E105KWJ1#

品名 # 表示包装规格代码。

GRM 系列
GJM 系列
GMA 系列
GMD 系列
GQM 系列
GRJ 系列
GR3 系列
KRM 系列
KR3 系列
LLA 系列
LLL 系列
LLM 系列
LLR 系列
警告 / 注意事项

高效静电容量&耐高容许纹波电流

GR3 系列



抗噪

这款一般用高耐纹波电流产品，具有一流的直流偏置特性。

特点

- ① 施加直流偏置后，可获得比传统产品（X7R特性）更大的静电容量。
- ② 与传统产品（X7R特性）相比，耐纹波性能更高。

施加直流200V时可保证电容翻倍。

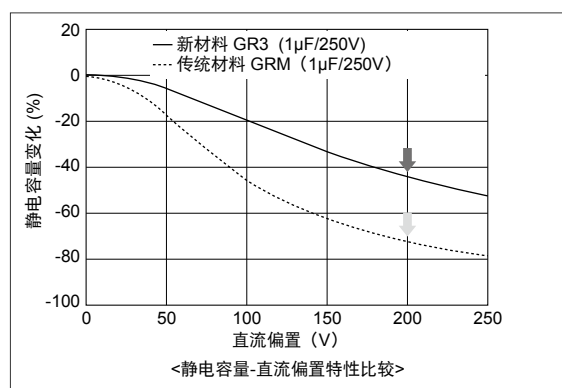

若是静电容量为1 μ F的产品，在频率f=300kHz的情况下放热温度达20 $^{\circ}$ C时，使用了传统材料的产品电阻值为2.9Ar.m.s；而新材料的则为4.7Ar.m.s。

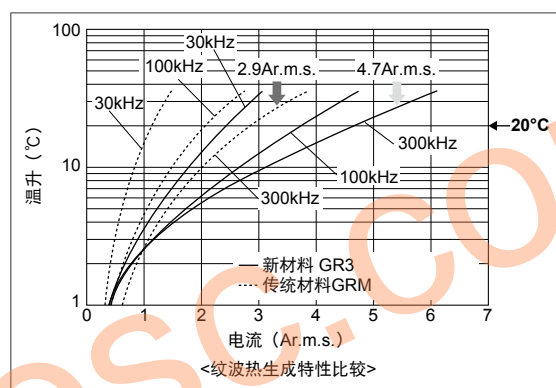

- ③ 本产品具有降噪效果。

由于使用了可降噪的介电材料，本产品较之于一般用GRM系列，具有更高效的降噪效果。

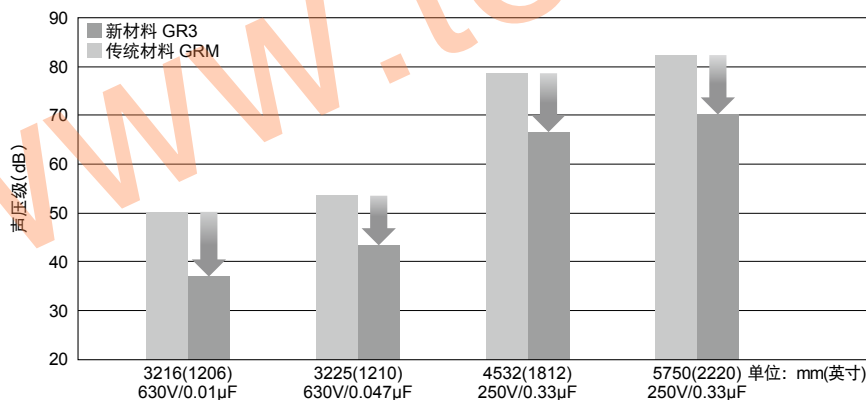

规格

尺寸	2.0 \times 1.25mm 到 5.7 \times 5.0mm
额定电压	DC250V 到 630V
静电容量	0.01 μ F 到 1.0 μ F
主要应用	用于电源的PFC（功率因数校正）电路、EMI抑制及平滑电路

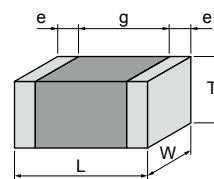

<尺寸>

本目录仅列出了部分产品系列。
 详情请参阅村田网站中的电容器检索工具。

GRM 系列

GJM 系列

GMA 系列

GMD 系列

GQM 系列

GRJ 系列

GR3 系列

KRM 系列

KR3 系列

LJA 系列

LLL 系列

LJM 系列

LLR 系列

警告 / 注意事项

GR3 系列高介电常数型 抗噪 品名列表

■ 2.0×1.25mm

T 最大值	额定电压	温度特性代号	静电容量	公差	品名
1.0mm	250Vdc	X7T	10000pF	±10%	GR321AD72E103KW01#
			15000pF	±10%	GR321AD72E153KW01#
1.45mm	250Vdc	X7T	22000pF	±10%	GR321BD72E223KW03#

■ 3.2×1.6mm

T 最大值	额定电压	温度特性代号	静电容量	公差	品名
1.0mm	450Vdc	X7T	10000pF	±10%	GR331AD72W103KW01#
			15000pF	±10%	GR331AD72W153KW01#
	250Vdc	X7T	33000pF	±10%	GR331AD72E333KW01#
1.25mm	630Vdc	X7T	10000pF	±10%	GR331BD72J103KW01#
			22000pF	±10%	GR331BD72W223KW01#
	33000pF	±10%	GR331BD72W333KW01#		
1.8mm	630Vdc	X7T	15000pF	±10%	GR331CD72J153KW03#
			47000pF	±10%	GR331CD72W473KW03#
	250Vdc	X7T	68000pF	±10%	GR331CD72E683KW03#

■ 3.2×2.5mm

T 最大值	额定电压	温度特性代号	静电容量	公差	品名
1.5mm	630Vdc	X7T	22000pF	±10%	GR332QD72J223KW01#
			0.10μF	±10%	GR332QD72E104KW01#
2.0mm	630Vdc	X7T	33000pF	±10%	GR332DD72J333KW01#
			47000pF	±10%	GR332DD72J473KW01#
	450Vdc	X7T	68000pF	±10%	GR332DD72W683KW01#
			0.10μF	±10%	GR332DD72W104KW01#
250Vdc	X7T	0.15μF	±10%	GR332DD72E154KW01#	

■ 4.5×3.2mm

T 最大值	额定电压	温度特性代号	静电容量	公差	品名
1.5mm	250Vdc	X7T	0.22μF	±10%	GR343QD72E224KW01#
2.0mm	630Vdc	X7T	68000pF	±10%	GR343DD72J683KW01#
			0.15μF	±10%	GR343DD72W154KW01#
	250Vdc	X7T	0.33μF	±10%	GR343DD72E334KW01#

■ 5.7×5.0mm

T 最大值	额定电压	温度特性代号	静电容量	公差	品名
2.0mm	630Vdc	X7T	0.10μF	±10%	GR355DD72J104KW01#
			0.15μF	±10%	GR355DD72J154KW01#
	450Vdc	X7T	0.22μF	±10%	GR355DD72W224KW01#
			0.33μF	±10%	GR355DD72W334KW01#
			0.47μF	±10%	GR355DD72W474KW01#
250Vdc	X7T	0.47μF	±10%	GR355DD72E474KW01#	
		0.68μF	±10%	GR355DD72E684KW01#	
2.7mm	630Vdc	X7T	0.22μF	±10%	GR355XD72J224KW05#

T 最大值	额定电压	温度特性代号	静电容量	公差	品名
2.7mm	630Vdc	X7T	0.27μF	±10%	GR355XD72J274KW05#
	450Vdc	X7T	0.56μF	±10%	GR355XD72W564KW05#
	250Vdc	X7T	1.0μF	±10%	GR355XD72E105KW05#

品名 # 表示包装规格代码。

一般用金属端子型 KRM 系列



抗噪 裂纹偏转 焊接断裂

通过将金属端子粘合在外部电极上，解决了如何贴装在大尺寸MLCC上的设计难题！

特点

① 将金属端子粘合在贴片的外部电极上。

通过金属端子的弹性特性大大减低了施加在贴片上的压力。

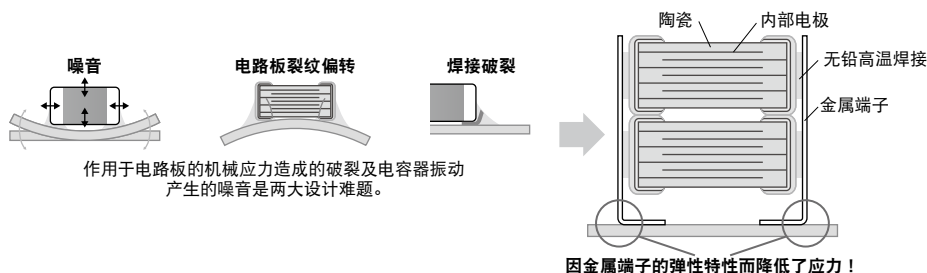

② 极大地减少了噪音、电路板裂纹偏转和焊接破裂。

即便电路板偏差6mm，本产品也不会断裂。

即便经受2000次热应力循环，也不会出现焊接破裂。

● 使用金属端子降低了噪声

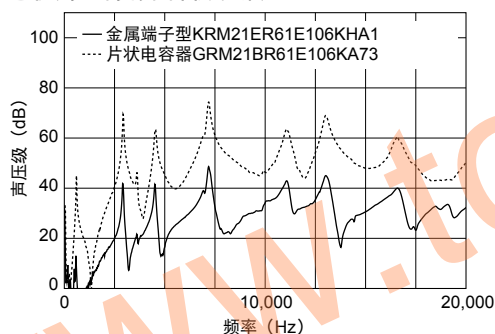

● 降低了因电路板弯曲引起的应力

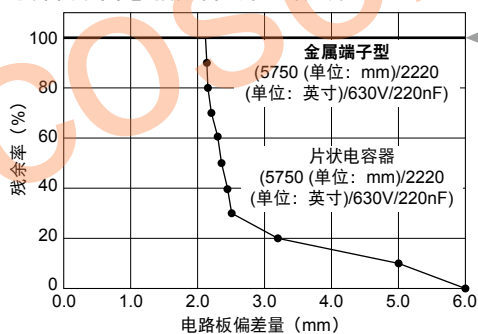

● 抑制因热应力引起的焊接破裂

贴片尺寸	单个贴片 (5750 (单位: mm)/2220 (单位: 英寸) 尺寸)	金属端子型 (5750 (单位: mm)/2220 (单位: 英寸) 尺寸)
1000 次循环	 ↑焊接破裂	
2000 次循环	 ↑焊接破裂	

与单个电容比较，本产品具有极佳的抗焊接破裂性。

测试条件: -55 到+125℃, 5分钟 (容器中)
 所用电路板: 玻璃环氧树脂板 (FR-4)

证明低噪音电容器的更换值，体验KRM系列的效率。

▶ 噪音对策示例

GRM 系列

GJM 系列

GMA 系列

GMD 系列

GQM 系列

GRJ 系列

GR3 系列

KRM 系列

KR3 系列

LJA 系列

LLL 系列

LJM 系列

LLR 系列

警告 / 注意事项

③ 2个贴片可堆叠。

通过堆叠2个电容器来获得大容量。

规格

尺寸	2.2×1.25mm 到 6.1×5.3mm
额定电压	DC16V 到 1kV
静电容量	0.068μF 到 68μF
主要应用	用于 DC-DC 转换器的滤波和抑噪

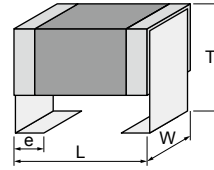

<尺寸>

本目录仅列出了部分产品系列。
 详情请参阅村田网站中的电容器检索工具。

www.tocosc.com

KRM 系列高介电常数型 Anti-noise Deflecting crack 焊接断裂 品名列表

■ 3.5×1.7mm

T 最大值	额定 电压	温度特 性代号	静电容量	公差	品名
2.0mm	25Vdc	X5R	10μF	±10%	KRM31FR61E106KH01#
2.9mm	100Vdc	X7R	1.0μF	±10%	KRM31KR72A105KH01#
	50Vdc	X7R	4.7μF	±10%	KRM31KR71H475KH01#
	35Vdc	X6S	10μF	±10%	KRM31KC8YA106KH01#
	25Vdc	X6S	10μF	±10%	KRM31KC81E106KH01#

T 最大值	额定 电压	温度特 性代号	静电容量	公差	品名
5.0mm	25Vdc	X7R	33μF	±20%	KRM55TR71E336MH01#
6.7mm	100Vdc	X7R	15μF	±20%	KRM55WR72A156MH01#
	63Vdc	X7R	22μF	±20%	KRM55WR71J226MH01#
	50Vdc	X7R	33μF	±20%	KRM55WR71H336MH01#
	35Vdc	X7R	47μF	±20%	KRM55WR7YA476MH01#
	25Vdc	X7R	47μF	±20%	KRM55WR71E476MH01#
			68μF	±20%	KRM55WR71E686MH01#

■ 3.6×1.7mm

T 最大值	额定 电压	温度特 性代号	静电容量	公差	品名
2.9mm	50Vdc	X7R	2.2μF	±10%	KRM31KR71H225KH01#

■ 3.7×1.85mm

T 最大值	额定 电压	温度特 性代号	静电容量	公差	品名
2.9mm	100Vdc	X7R	2.2μF	±10%	KRM31KR72A225KH01#

■ 6.1×5.3mm

T 最大值	额定 电压	温度特 性代号	静电容量	公差	品名
3.0mm	1000Vdc	X7R	68000pF	±10%	KRM55LR73A683KH01#
			0.10μF	±10%	KRM55LR73A104KH01#
	630Vdc	X7R	0.15μF	±10%	KRM55LR72J154KH01#
			0.22μF	±10%	KRM55LR72J224KH01#
	250Vdc	X7R	0.68μF	±10%	KRM55LR72E684KH01#
			1.0μF	±10%	KRM55LR72E105KH01#
	100Vdc	X7R	4.7μF	±10%	KRM55LR72A475KH01#
	63Vdc	X7R	4.7μF	±10%	KRM55LR71J475KH01#
	50Vdc	X7R	4.7μF	±10%	KRM55LR71H475KH01#
			10μF	±10%	KRM55LR71H106KH01#
	35Vdc	X7R	10μF	±10%	KRM55LR7YA106KH01#
			15μF	±10%	KRM55LR7YA156KH01#
	25Vdc	X7R	15μF	±10%	KRM55LR71E156KH01#
	3.9mm	100Vdc	X7R	6.8μF	±10%
63Vdc		X7R	10μF	±10%	KRM55QR71J106KH01#
50Vdc		X7R	17μF	±10%	KRM55QR71H176KH01#
35Vdc		X7R	17μF	±10%	KRM55QR7YA176KH01#
			22μF	±10%	KRM55QR7YA226KH01#
25Vdc		X7R	22μF	±10%	KRM55QR71E226KH01#
	33μF		±10%	KRM55QR71E336KH01#	
5.0mm	1000Vdc	X7R	0.15μF	±20%	KRM55TR73A154MH01#
			0.22μF	±20%	KRM55TR73A224MH01#
	630Vdc	X7R	0.33μF	±20%	KRM55TR72J334MH01#
			0.47μF	±20%	KRM55TR72J474MH01#
			1.5μF	±20%	KRM55TR72E155MH01#
	250Vdc	X7R	2.2μF	±20%	KRM55TR72E225MH01#
			10μF	±20%	KRM55TR72A106MH01#
	100Vdc	X7R	10μF	±20%	KRM55TR72A106MH01#
	50Vdc	X7R	22μF	±20%	KRM55TR71H226MH01#
	35Vdc	X7R	22μF	±20%	KRM55TR7YA226MH01#
33μF			±20%	KRM55TR7YA336MH01#	

品名 # 表示包装规格代码。

GRM 系列
GJM 系列
GMA 系列
GMD 系列
GQM 系列
GRJ 系列
GR3 系列
KRM 系列
KR3 系列
LLA 系列
LLL 系列
LLM 系列
LLR 系列
警告/注意事项

GRM 系列

GJM 系列

GMA 系列

GMD 系列

GQM 系列

GRU 系列

GR3 系列

KRM 系列

KR3 系列

LJA 系列

LLL 系列

LJM 系列

LLR 系列

警告 / 注意事项

金属端子型高效电容&耐高纹波电流

KR3 系列



- 抗噪
- 裂纹偏转
- 焊接断裂

通过将金属端子粘合在外部电极上，解决了如何贴装在大尺寸MLCC上的设计难题！

特点

① 将金属端子粘合在贴片的外部电极上。

通过金属端子的弹性特性大大减低了施加在贴片上的压力。

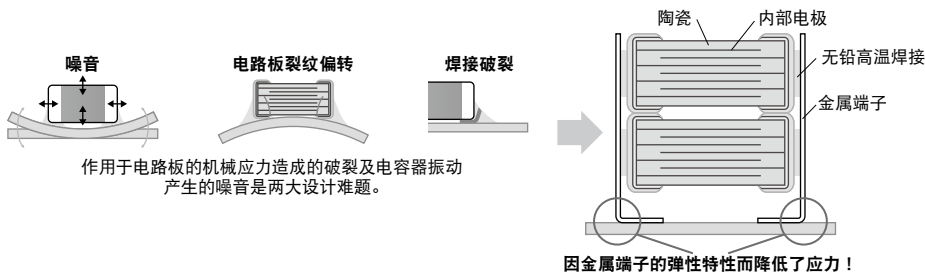

② 极大地减少了噪音、电路板裂纹偏转和焊接破裂。

即便电路板偏差6mm，本产品也不会断裂。

即使经受2000次热应力循环，也不会出现焊接破裂。

● 降噪效果比较

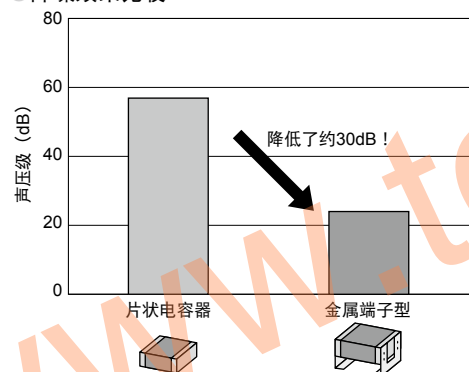

评估项目：5750 (单位：mm)/2220 (单位：英寸) 尺寸/DC630V/220nF
 测试方法：DC50V, AC10Vp-p/3kHz
 电路板测试：玻璃环氧树脂板 (厚：1.6mm)
 测试数量：3件
 麦克风和电路板之间的距离：3mm

注：使用村田评估板获得的结果

● 降低了因电路板弯曲引起的应力

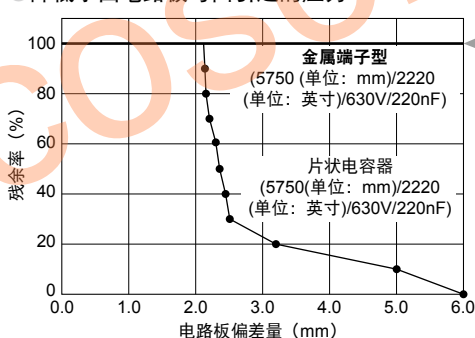

即便电路板偏差达6mm，也不会损坏！！

● 抑制因热应力引起的焊接破裂

贴片尺寸	单个贴片 (5750 (单位：mm)/2220 (单位：英寸) 尺寸)	金属端子型 (5750 (单位：mm)/2220 (单位：英寸) 尺寸)
1000 次循环	 ↑焊接破裂	
2000 次循环	 ↑焊接破裂	

与单个电容比较，本产品具有极佳的抗焊接破裂性。

测试条件：-55 到 +125℃，5分钟 (容器中)
 所用电路板：玻璃环氧树脂板 (FR-4)

③ 使用低介电常数材料

与传统产品（X7R特性）相比，提高了有效容量和耐纹波性能。

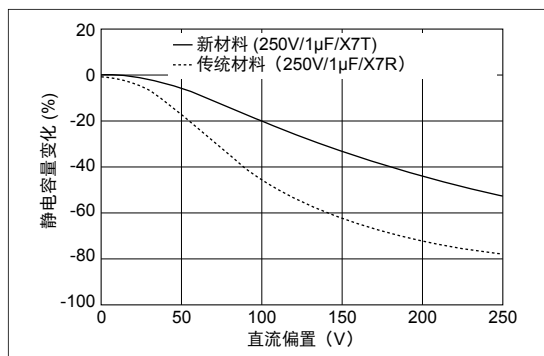

规格

尺寸	6.1×5.3mm
额定电压	DC250V 到 630V
静电容量	0.1μF 到 2.2μF
主要应用	用于普通电子设备的DC-DC转换器

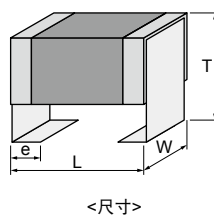

本目录仅列出了部分产品系列。
 详情请参阅村田网站中的电容器检索工具。

www.tocosc.com

- GRM 系列
- GJM 系列
- GMA 系列
- GMD 系列
- GQM 系列
- GRJ 系列
- GR3 系列
- KRM 系列
- KR3 系列
- LLA 系列
- LLL 系列
- LLM 系列
- LLR 系列
- 警告 / 注意事项

GRM 系列

GJM 系列

GMA 系列

GMD 系列

GQM 系列

GRJ 系列

GR3 系列

KRM 系列

KR3 系列

LLA 系列

LLL 系列

LLM 系列

LLR 系列

警告 / 注意 事项

KR3 系列高介电常数型 品名列表

■ 6.1×5.3mm

T 最大值	额定电压	温度特性代号	静电容量	公差	品名
3.0mm	630Vdc	X7T	0.10μF	±10%	KR355LD72J104KH01#
			0.15μF	±10%	KR355LD72J154KH01#
	450Vdc	X7T	0.22μF	±10%	KR355LD72W224KH01#
			0.33μF	±10%	KR355LD72W334KH01#
			0.47μF	±10%	KR355LD72W474KH01#
	250Vdc	X7T	0.47μF	±10%	KR355LD72E474KH01#
0.68μF			±10%	KR355LD72E684KH01#	
3.9mm	630Vdc	X7T	0.22μF	±10%	KR355QD72J224KH01#
			0.27μF	±10%	KR355QD72J274KH01#
	450Vdc	X7T	0.56μF	±10%	KR355QD72W564KH01#
			250Vdc	X7T	1.0μF
5.0mm	450Vdc	X7T	0.68μF	±20%	KR355TD72W684MH01#
			1.0μF	±20%	KR355TD72W105MH01#
	250Vdc	X7T	1.5μF	±20%	KR355TD72E155MH01#
6.7mm	630Vdc	X7T	0.47μF	±20%	KR355WD72J474MH01#
			0.56μF	±20%	KR355WD72J564MH01#
	450Vdc	X7T	1.2μF	±20%	KR355WD72W125MH01#
			250Vdc	X7T	2.2μF

8-端子低 ESL 型 LLA 系列



8-端子型低电感值（ESL值）电容器是高速运转IC设备的电源去耦的理想选择。

特点

① 超低ESL

由于等效串联电感（ESL）极低且因设计结构具有卓越的高频特性，该电容器非常适合用于高速运转IC设备的电源去耦。

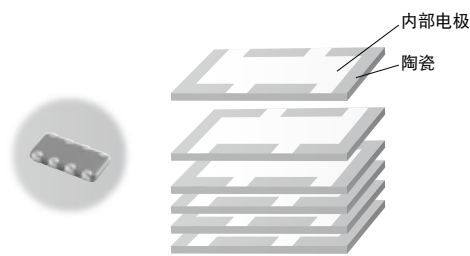

< 结构示例 >

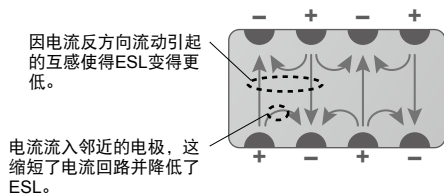

< 通过互感来消除电感的有效性 >

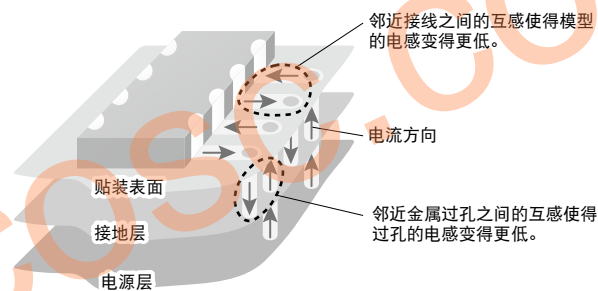

< 贴装多端子电容器时抑制电感的有效性 >

不仅仅电容器，电路板的电感也变得更低。

② 最大工作温度达125℃。

本产品可在高温下使用（X7*特性），不过，村田还供应多款适合在IC封装上作为去耦电容器使用的薄型产品。

规格

尺寸	1.6×0.8mm 到 3.2×1.6mm
额定电压	DC4V 到 25V
静电容量	0.01μF 到 4.7μF
主要应用	用于处理器/CPU/GPU

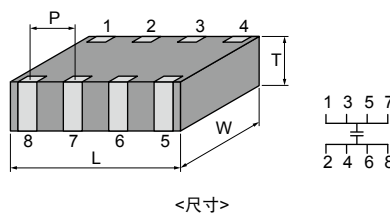

<尺寸>

本目录仅列出了部分产品系列。
 详情请参阅村田网站中的电容器检索工具。

GRM 系列
GJM 系列
GMA 系列
GMD 系列
GQM 系列
GRJ 系列
GR3 系列
KRM 系列
KR3 系列
LLA 系列
LLL 系列
LLM 系列
LLR 系列
警告/注意事项

LLA 系列高介电常数型 低ESL型 品名列表

■ 1.6×0.8mm

T 最大值	额定 电压	温度特 性代号	静电容量	公差	品名
0.55mm	4Vdc	X7S	0.10μF	±20%	LLA185C70G104MA01#
			0.22μF	±20%	LLA185C70G224MA01#
			0.47μF	±20%	LLA185C70G474MA01#
			2.2μF	±20%	LLA185C70G225ME16#

■ 2.0×1.25mm

T 最大值	额定 电压	温度特 性代号	静电容量	公差	品名
0.55mm	25Vdc	X7R	10000pF	±20%	LLA215R71E103MA14#
			22000pF	±20%	LLA215R71E223MA14#
	16Vdc	X7R	47000pF	±20%	LLA215R71C473MA14#
			0.10μF	±20%	LLA215R71C104MA14#
	10Vdc	X7R	0.22μF	±20%	LLA215R71A224MA14#
	6.3Vdc	X7R	0.47μF	±20%	LLA215R70J474MA14#
	4Vdc	X7S	1.0μF	±20%	LLA215C70G105MA14#
			4.7μF	±20%	LLA215C70G475ME19#
0.95mm	25Vdc	X7R	10000pF	±20%	LLA219R71E103MA01#
			22000pF	±20%	LLA219R71E223MA01#
			47000pF	±20%	LLA219R71E473MA01#
	16Vdc	X7R	0.10μF	±20%	LLA219R71C104MA01#
			0.22μF	±20%	LLA219R71C224MA01#
	10Vdc	X7R	0.47μF	±20%	LLA219R71A474MA01#
	6.3Vdc	X7R	1.0μF	±20%	LLA219R70J105MA01#
	4Vdc	X7S	2.2μF	±20%	LLA219C70G225MA01#

■ 3.2×1.6mm

T 最大值	额定 电压	温度特 性代号	静电容量	公差	品名
0.55mm	16Vdc	X7R	0.22μF	±20%	LLA315R71C224MA14#
	10Vdc	X7R	0.47μF	±20%	LLA315R71A474MA14#
	6.3Vdc	X7R	1.0μF	±20%	LLA315R70J105MA14#
			2.2μF	±20%	LLA315R70J225MA14#
0.95mm	16Vdc	X7R	0.47μF	±20%	LLA319R71C474MA01#
	10Vdc	X7R	1.0μF	±20%	LLA319R71A105MA01#
1.25mm	16Vdc	X7R	1.0μF	±20%	LLA31MR71C105MA01#
	10Vdc	X7R	2.2μF	±20%	LLA31MR71A225MA01#

- GRM 系列
- GJM 系列
- GMA 系列
- GMD 系列
- GQM 系列
- GRJ 系列
- GR3 系列
- KRM 系列
- KR3 系列
- LLA 系列
- LLL 系列
- LLM 系列
- LLR 系列
- 警告 / 注意事项

品名 # 表示包装规格代码。

长宽逆转低 ESL 型

LLL 系列



这款低ESL电容器非常适合用于高速运转电子设备的电源去耦。

特点

① 低 ESL 型

由于等效串联电感（ESL）极低且具有极佳的高频特性，该电容器非常适合用于高速运转电子设备的电源去耦。

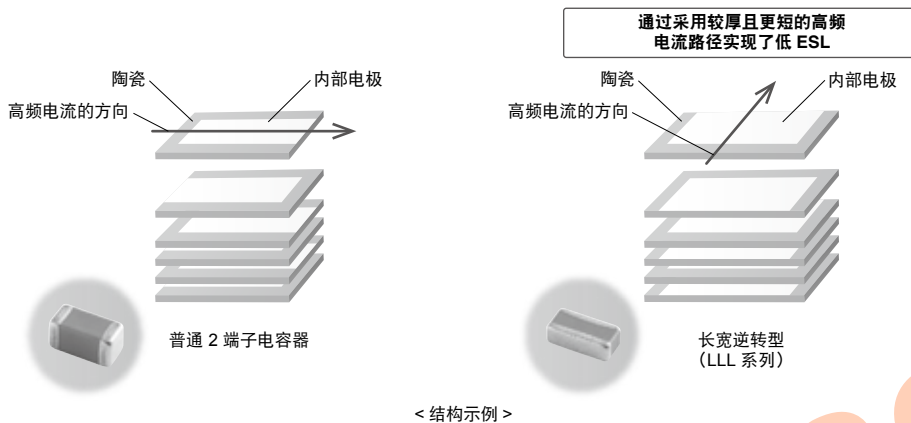

② 有助于减少元件的个数。

使用低ESL电容器可减少元件的个数，同时具有与一般用电容器（GRM系列）相当的功能。

村田建议使用LLL系列来减少元件的个数以及降低高成本。还可用于模拟。降低成本的建议。

降低成本的建议

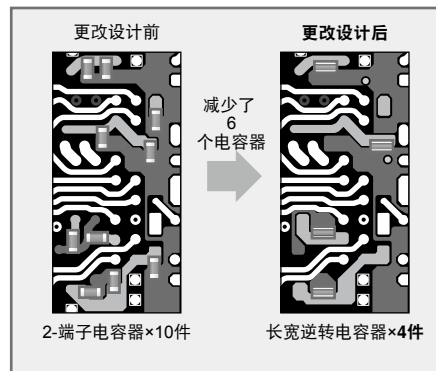

③ 最大工作温度达125℃。

村田还提供多款可在高温条件下使用（如IC封装）且具有X7*特性的产品系列。

规格

尺寸	0.5×1.0mm 到 1.6×3.2mm
额定电压	DC2.5V 到 50V
静电容量	2,200pF 到 10μF
主要应用	用于处理器/CPU/GPU

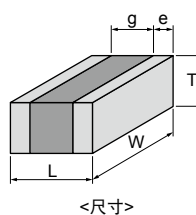

本目录仅列出了部分产品系列。
 详情请参阅村田网站中的电容器检索工具。

LLL 系列高介电常数型 Low ESL 品名列表

■ 0.5×1.0mm

T 最大值	额定 电压	温度特 性代号	静电容量	公差	品名
0.35mm	6.3Vdc	X6S	0.10μF	±20%	LLL153C80J104ME01#
			0.22μF	±20%	LLL153C80J224ME14#
	4Vdc	X7S	0.47μF	±20%	LLL153C70G474ME17#
		X6S	1.0μF	±20%	LLL153C80G105ME21#

■ 0.6×1.0mm

T 最大值	额定 电压	温度特 性代号	静电容量	公差	品名
0.45mm	4Vdc	X5R	4.3μF	±20%	LLL1U4R60G435ME22# <small>Deraing</small>

■ 0.8×1.6mm

T 最大值	额定 电压	温度特 性代号	静电容量	公差	品名
0.5mm	25Vdc	X7R	10000pF	±20%	LLL185R71E103MA11#
			22000pF	±20%	LLL185R71C223MA11#
			47000pF	±20%	LLL185R71C473MA11#
	10Vdc	X7R	0.10μF	±20%	LLL185R71A104MA11#
0.55mm	4Vdc	X7S	0.22μF	±20%	LLL185C70G224MA11#
			2.2μF	±20%	LLL185C70G225ME01#
0.6mm	50Vdc	X7R	2200pF	±20%	LLL185R71H222MA01#
			4700pF	±20%	LLL185R71H472MA01#
	25Vdc	X7R	10000pF	±20%	LLL185R71E103MA01#
			22000pF	±20%	LLL185R71E223MA01#
			47000pF	±20%	LLL185R71C473MA01#
	16Vdc	X7R	0.10μF	±20%	LLL185R71A104MA01#
			0.22μF	±20%	LLL185R71A224MA01#
	10Vdc	X7R	0.10μF	±20%	LLL185R71A104MA01#
			0.22μF	±20%	LLL185R71A224MA01#
	4Vdc	X7S	0.47μF	±20%	LLL185C70G474MA01#

■ 1.25×2.0mm

T 最大值	额定 电压	温度特 性代号	静电容量	公差	品名
0.5mm	50Vdc	X7R	10000pF	±20%	LLL215R71H103MA11#
			22000pF	±20%	LLL215R71E223MA11#
			47000pF	±20%	LLL215R71C473MA11#
	10Vdc	X7R	0.10μF	±20%	LLL215R71C104MA11#
			0.22μF	±20%	LLL215R71A224MA11#
			0.47μF	±20%	LLL215R70J474MA11#
			1.0μF	±20%	LLL215C70G105MA11#
0.7mm	50Vdc	X7R	10000pF	±20%	LLL216R71H103MA01#
			22000pF	±20%	LLL216R71H223MA01#
	25Vdc	X7R	47000pF	±20%	LLL216R71E473MA01#
			0.10μF	±20%	LLL216R71E104MA01#
			0.22μF	±20%	LLL216R71A224MA01#
0.95mm	16Vdc	X7R	0.22μF	±20%	LLL219R71C224MA01#
			0.47μF	±20%	LLL219R71A474MA01#
	10Vdc	X7R	0.47μF	±20%	LLL219R71A474MA01#
			1.0μF	±20%	LLL219R71A105MA01#
4Vdc	X7S	2.2μF	±20%	LLL219C70G225MA01#	

■ 1.6×3.2mm

T 最大值	额定 电压	温度特 性代号	静电容量	公差	品名
0.5mm	50Vdc	X7R	10000pF	±20%	LLL315R71H103MA11#
			22000pF	±20%	LLL315R71H223MA11#
			47000pF	±20%	LLL315R71E473MA11#
	25Vdc	X7R	0.10μF	±20%	LLL315R71E104MA11#
			0.22μF	±20%	LLL315R71C224MA11#
			0.47μF	±20%	LLL315R71A474MA11#
0.8mm	50Vdc	X7R	10000pF	±20%	LLL317R71H103MA01#
			22000pF	±20%	LLL317R71H223MA01#
			47000pF	±20%	LLL317R71H473MA01#
	25Vdc	X7R	0.10μF	±20%	LLL317R71E104MA01#
			0.22μF	±20%	LLL317R71C224MA01#
			0.47μF	±20%	LLL317R71C474MA01#
	16Vdc	X7R	0.22μF	±20%	LLL317R71C224MA01#
			0.47μF	±20%	LLL317R71C474MA01#
			1.0μF	±20%	LLL317R71A105MA01#
6.3Vdc	X7R	2.2μF	±20%	LLL317R70J225MA01#	
1.25mm	50Vdc	X7R	0.10μF	±20%	LLL31MR71H104MA01#
			0.22μF	±20%	LLL31MR71E224MA01#
			0.47μF	±20%	LLL31MR71E474MA01#
	16Vdc	X7R	1.0μF	±20%	LLL31MR71C105MA01#
			2.2μF	±20%	LLL31MR71A225MA01#
			4.7μF	±20%	LLL31MR70J475MA01#
6.3Vdc	X7R	4.7μF	±20%	LLL31MR70J475MA01#	
	X5R	10μF	±20%	LLL31MR60J106ME01#	

品名 # 表示包装规格代码。

GRM 系列
GJM 系列
GMA 系列
GMD 系列
GQM 系列
GRJ 系列
GR3 系列
KRM 系列
KR3 系列
LLA 系列
LLL 系列
LLM 系列
LLR 系列
警告 / 注意 事项

10 端子低 ESL 型 LLM 系列



10-端子型低电感值（ESL值）电容器是高速运转IC设备的电源去耦的理想选择。

特点

① 这是一款最低ESL值的长宽逆转型电容器。

由于本产品的等效串联电感（ESL）甚至比具有卓越的高频特性的LLA系列（8-端子产品）的要低，该电容器非常适合用于高速运转IC设备的电源去耦。

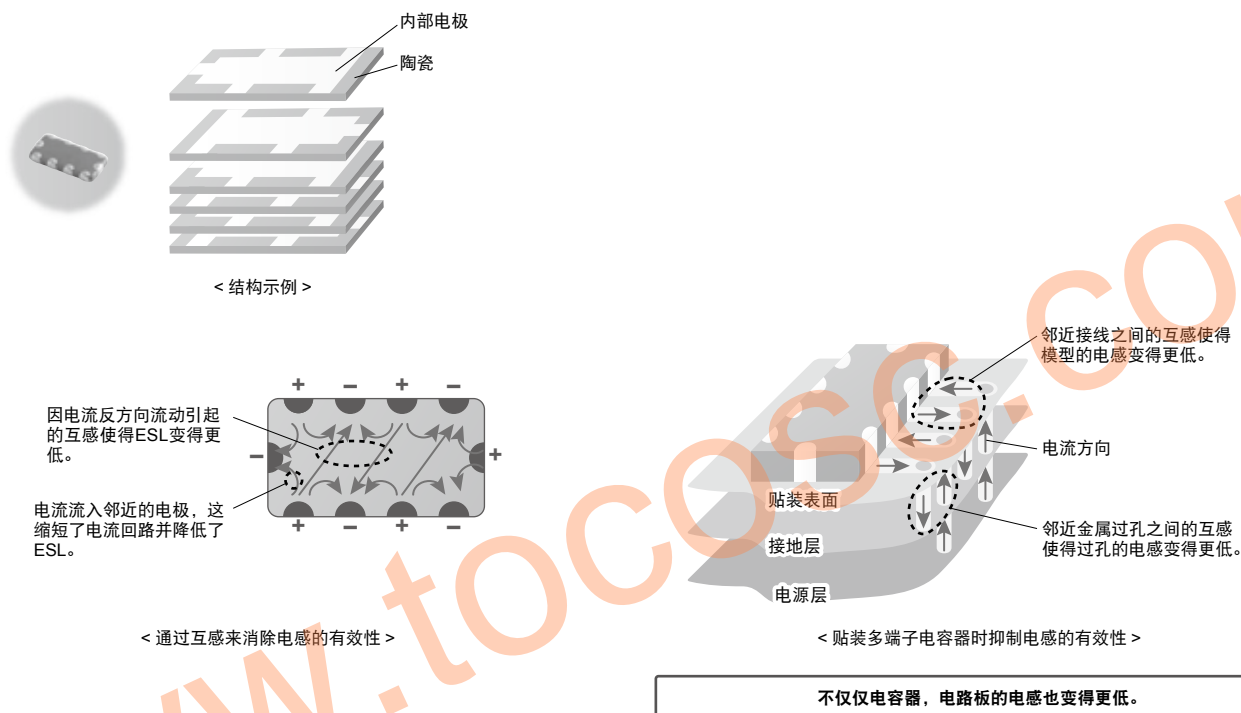

② 最大工作温度达125℃。

本产品可在高温下使用（X7*特性），不过，村田还供应多款适合在IC封装上作为去耦电容器使用的薄型产品。

规格

尺寸	2.0×1.25mm 到 3.2×1.6mm
额定电压	DC4V 到 16V
静电容量	0.1μF 到 2.2μF
主要应用	用于处理器/CPU/GPU

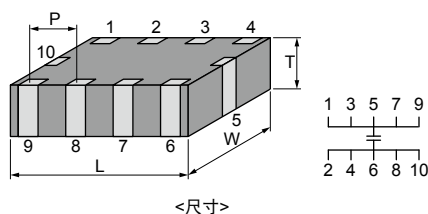

本目录仅列出了部分产品系列。
 详情请参阅村田网站中的电容器检索工具。

GRM 系列

GJM 系列

GMA 系列

GMD 系列

GQM 系列

GRJ 系列

GR3 系列

KRM 系列

KR3 系列

LLA 系列

LLL 系列

LLM 系列

LLR 系列

警告 / 注意事项

LLM 系列高介电常数型 Low ESL 品名列表

■ 2.0×1.25mm

T 最大值	额定电压	温度特性代号	静电容量	公差	品名
0.55mm	6.3Vdc	X7R	0.22μF	±20%	LLM215R70J224MA11#
			0.47μF	±20%	LLM215R70J474MA11#
	4Vdc	X7S	1.0μF	±20%	LLM215C70G105MA11#

■ 3.2×1.6mm

T 最大值	额定电压	温度特性代号	静电容量	公差	品名
0.55mm	16Vdc	X7R	0.10μF	±20%	LLM315R71C104MA11#
			0.22μF	±20%	LLM315R71C224MA11#
	10Vdc	X7R	0.47μF	±20%	LLM315R71A474MA11#
	6.3Vdc	X7R	2.2μF	±20%	LLM315R70J225MA11#

ESR控制低 ESL 型

LLR 系列



ESR控制型低ESL电容器具有反谐振控制功能

特点

① 减少了反谐振

通过控制电容器，等效串联电阻（ESR）稍稍变高，同时有效地减少了使用电容器阵列时出现的反谐振。

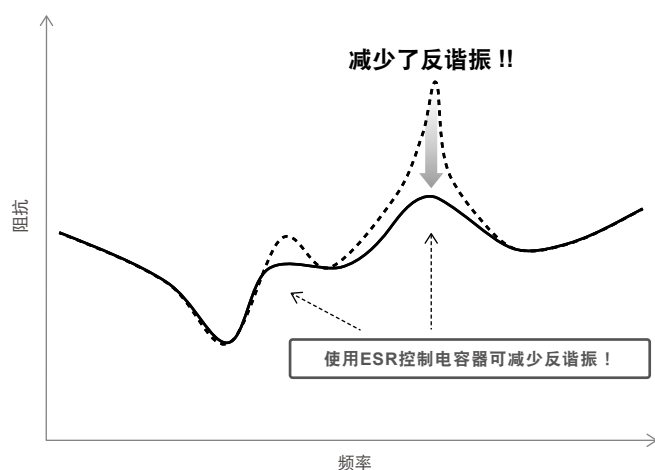

② ESR值介于100-1000m的电容器系列。

根据反谐振的条件，多数合适的ESR值可从4种类型中选择。

③ 低 ESL 型

这款ESR控制型电容器具有极佳的高频特性和低等效串联电感（ESL）值。其还非常适合作去耦元件。其还非常适合作去耦元件。

规格

尺寸	0.8×1.6mm
额定电压	DC4V
静电容量	1.0μF
主要应用	网络处理器/ASIC/PMIC

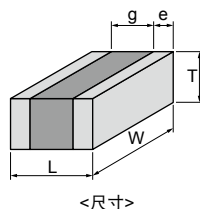

<尺寸>

本目录仅列出了部分产品系列。
 详情请参阅村田网站中的电容器检索工具。

GRM 系列

GJM 系列

GMA 系列

GMD 系列

GQM 系列

GRJ 系列

GR3 系列

KRM 系列

KP3 系列

LLA 系列

LLL 系列

LLM 系列

LLR 系列

警告 / 注意事项

GRM 系列

GJM 系列

GMA 系列

GMD 系列

GQM 系列

GRJ 系列

GR3 系列

KRM 系列

KR3 系列

LLA 系列

LLL 系列

LLM 系列

LLR 系列

警告 / 注意事项

LLR 系列高介电常数型 **LOW ESL** 品名列表

■ 0.8×1.6mm

T 最大值	额定 电压	温度特 性代号	静电容量	公差	品名
0.55mm	4Vdc	X7S	1.0μF	±20%	LLR185C70G105ME01#
				±20%	LLR185C70G105ME03#
				±20%	LLR185C70G105ME05#
				±20%	LLR185C70G105ME07#

www.tocosc.com

⚠警告/注意事项

⚠警告

- 存放与使用条件 142
- 额定值 142
 - 1. 温度依赖特性 142
 - 2. 静电容量测量 142
 - 3. 施加电压 143
 - 4. 施加电压类型和自发热温度 143
 - 5. 直流电压和交流电压特性 146
 - 6. 电容老化 146
 - 7. 振动和冲击 147
- 焊接与贴装 147
 - 1. 贴装位置 147
 - 2. 贴装前信息 148
 - 3. 贴装机（取放）的维护 148
 - 4-1. 回流焊接 149
 - 4-2. 波峰焊接 150
 - 4-3. 焊接部分的校正 151
 - 5. 清洗 152
 - 6. 印刷电路板电气试验 152
 - 7. 印刷电路板裁切 152
 - 8. 组装 155
 - 9. 元件结合 / 引线结合 156
- 其他 156
 - 1. 设备运行时 156
 - 2. 其他 156

注意事项

- 额定值 157
 - 1. 工作温度 157
 - 2. 周围环境 (气体和液体) 157
 - 3. 压电现象 157
- 焊接与贴装 157
 - 1. PCB设计 157
 - 1. 布局注意事项 157
 - 2. 焊盘尺寸 158
 - 3. 电路板设计 160
 - 2. 粘合剂的使用 160
 - 3. 粘合剂固化 160
 - 4. 回流和波峰焊接的助焊剂 161
 - 5. 波峰焊接 161
 - 6. 清洗 161
 - 7. 涂层 161
- 其他 162
 - 1. 运输 162
 - 2. 实际系统中的特性评估 162

GRM 系列

GJM 系列

GMA 系列

GMD 系列

GQM 系列

GRJ 系列

GR3 系列

KRM 系列

KR3 系列

LLA 系列

LLL 系列

LLM 系列

LLR 系列

⚠警告 / 注意事项

警告

■ 存放与使用条件

1. 片状多层陶瓷电容器的性能可能会受到存放条件的影响。

1-1. 在下列条件下存放电容器：

室温为5℃到40℃，相对湿度为20%到70%。

- (1) 存放期间的日照、灰尘、温度急剧变化、腐蚀性气体或高温和高湿等可能会影响其可焊性及封装性能。因此，请保持其储存温度和湿度。请在交货后6个月内使用，储存期过长可能导致电极氧化。
- (2) 超过6个月后，使用前请确认其可焊性。存放电容器时不要打开原包装袋。即使存放时间很短，也不要超过规定的环境条件。

- 1-2. 腐蚀性气体可能会对外部电极或电容器引线产生影响，导致可焊性变差。切勿在腐蚀性气体（例如 硫化氢、二氧化硫、氯气和氨气等）环境中存放电容器。
- 1-3. 由于湿度急剧变化引起的水气凝结或阳光直射引起外部电极、树脂、环氧涂层产生光化学变化，都会导致可焊性和电气性能变差。切勿在阳光直射或高湿条件下存放电容器。

■ 额定值

1. 温度依赖特性

1. 电容器的电气特性会随温度而变化。

1-1. 对于具有较大温度依赖性的电容器，其静电容量可能会随温度变化而变化。

为了确保获得合适的电容值，建议采取以下措施。

(1) 选择在工作温度范围内合适的静电容量。

(2) 该静电容量可能会在额定温度范围内变化。

您在需要静电容量变化小的电路中使用高介电常数型电容器时，例如 时间常数电路，请仔细考虑温度特性，并仔细确认实际应用条件及实际系统下的不同特性。

[典型温度特性图 X7R]]

示例：0.1μF，额定电压 50VDC

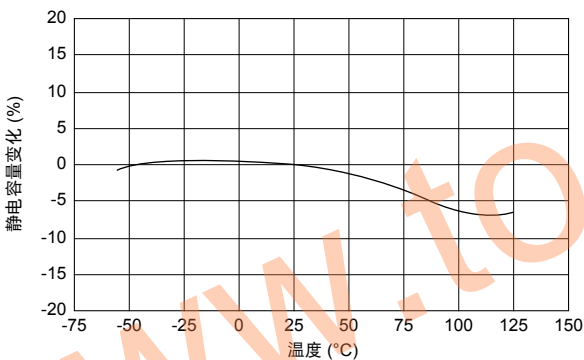

[典型温度特性图 X5R]]

示例：22μF，额定电压 4VDC

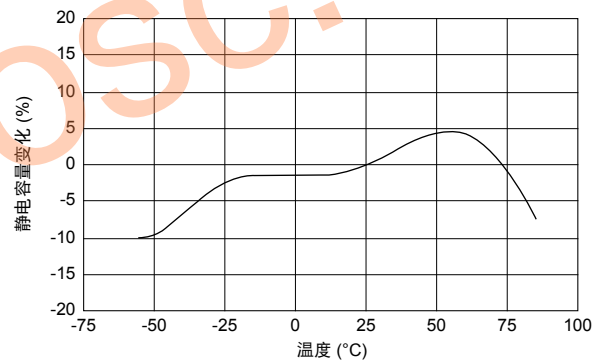

2. 静电容量测量

1. 在产品规格规定的电压和频率下测量静电容量。

1-1. 测量大容量电容时，有时会导致测量设备输出电压降低，从而引起测量误差。

请确认实际施加于电容器上的电压是否符合指定条件。

1-2. 高介电常数型电容器的静电容量会随施加的交流电压而变化。选择在交流电路中使用的电容器时，请考虑交流电压特性。

接下页。



☐ 接上页。

3. 施加电压

1. 向电容器施加的电压切勿超过其规定的额定电压。

1-1. 电容器外部电极之间的施加电压应小于或等于额定电压。

(1) 交流电压与直流电压叠加时，峰值不应超过额定直流电压。

施加交流电压或脉冲电压时，峰峰值不应超过额定直流电压。

(2) 异常电压（浪涌电压、静电和脉冲电压等）不应超过额定直流电压。

施加到电容器上的典型电压

直流电压	直流电压+交流	交流电压	脉冲电压

(E: 可能施加的最大电压)

1-2. 过电压影响

施加到电容器的过电压可能会导致电容器内部介电层击穿而引起电气短路。

击穿前的可持续时间取决于施加电压和周围温度。

2. 由于还需考虑每个设备所界定的耐电压和冲击耐电压，因此请在电源输入电路（交流滤波器）中使用经安全规格认证的电容器。

4. 施加电压类型和自发热温度

1. 确认工作条件，确保不会因连续施加交流电压和脉冲电压而导致有大电流流入电容器。

在交流电压电路或脉冲电压电路中使用直流额定电压产品时，交流电流或脉冲电流会流入电容器；因此，请检查自发热条件。

请确认电容器的表面温度，包括因自发热引起的温升，确保温度处于工作温度的上限之内。当电容器在高频电压或脉冲电压下使用时，介电损耗可能产生热。

<适用于小于100VDC的额定电压>

1-1. 负荷应达到以下水平：周围温度为25℃时进行测量时，产品自发热保持20℃以下，实际电路中的电容器表面温度保持在最高工作温度范围内。

[与纹波电流相比，片状多层陶瓷电容器温升（热生成）示例]
 示例：R (R1) 特性 10μF，额定电压：DC10V

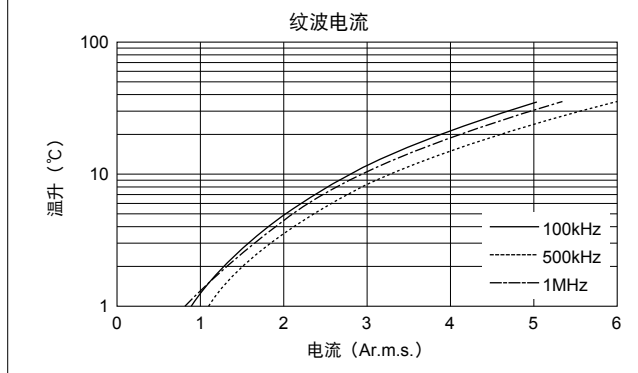

☐ 接下页。

- GRM 系列
- GJM 系列
- GMA 系列
- GMD 系列
- GQM 系列
- GRJ 系列
- GR3 系列
- KRM 系列
- KR3 系列
- LLA 系列
- LLL 系列
- LLM 系列
- LLR 系列
- 警告

警告

接上页。

<适用于超过额定电压 200VDC 的温度特性 X7R (R7), X7T (D7)>

1-2. 负载应控制在以下水平：环境温度为25℃进行测量时，电容器器体的自发热温度应保持在20℃以下。此外，测量时使用具有较小热容量的 $\phi 0.1\text{mm}$ K 热电偶，在没有其他元件热辐射及对流造成空气流动影响的条件下进行测量。过多热量的产生可能会导致电容器特性退化和可靠度降低。（由于在冷却风扇正常运转时无法准确测量，因此绝对不要在此条件下进行测量。）

<适用于超过额定电压的温度特国内U2J (7U), C0G (5C)>
 1-3. 由于低损耗系列中自发热较低，相较于常见的X7R特性，容许功率变得极高。

然而，在额定电压下施加自发热温度达20℃的负载时，可能会超出容许功率。电容器在大于1kHz或更高的高频电压回路中使用，施加电压的频率应小于500kHz正弦波（额定电压为DC3.15kV的产品应小于100kHz），以限制电压负载，确保负载保持在下图所示的降低定额定值之内。在非正弦波的情况下，可使用超过基本频率的高频元件。这种情况下，请联系村田公司。过多热量的产生可能会导致电容器特性退化和可靠度降低。

（由于在冷却风扇正常运转时无法准确测量，因此绝对不要在此条件下进行测量。）

电容器的表面温度: 125℃或以下 (包括自生热)

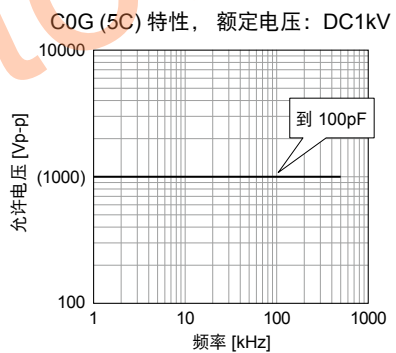
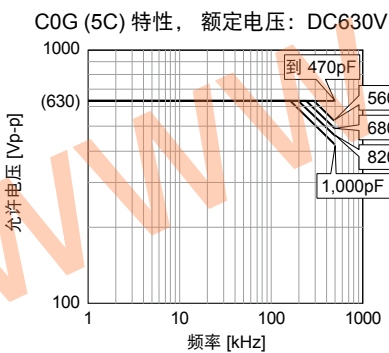
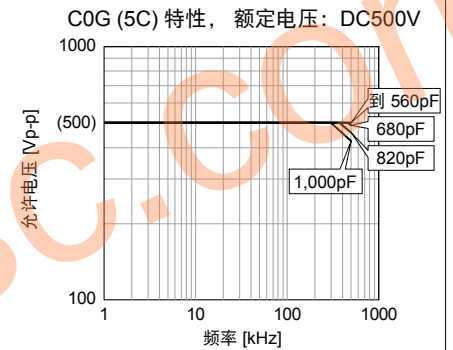
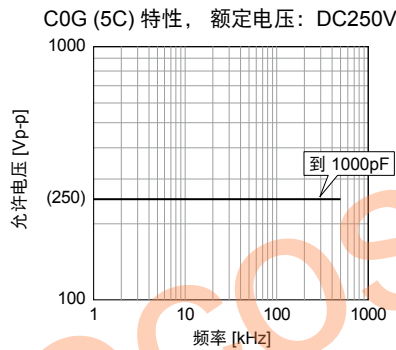
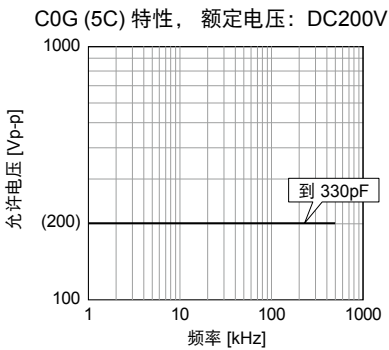

正弦频率 VS 容许电压

接下页。



☐ 接上页。

电容器的表面温度: 125°C或以下 (包括自生热)

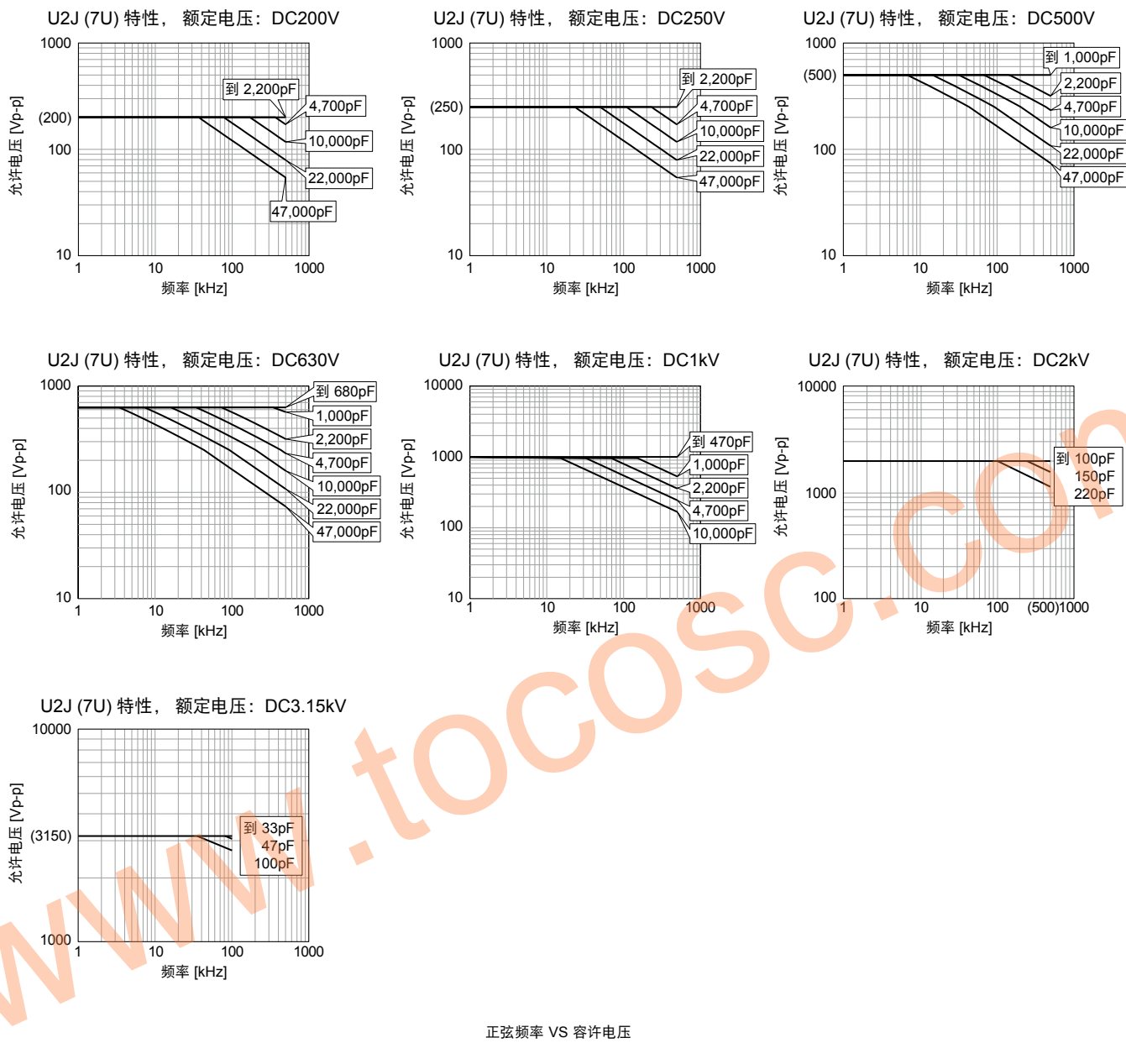

<设计工具>

· Simsurfing

Simsurfing是一款网络应用程序，用来显示村田产品的特性图表以及下载特性数据。可查看频率特性、温度特性、偏置特性等。

(网址: <http://www.murata.com/simsurfing/>)

· 中压陶瓷电容器选择工具

选择工具“取决于电压波形的村田中压电容器选择工具”安装在上述SimSurfing中，可根据包括汽车在内的应用确定首选中压陶瓷电容器的可用性。

使用该工具，可按各种规格，比如功率、电压以及输入至电容器的电压波形基本频率来查看首选产品*。

*支持系列

温度特性为U2J (7U), C0G (5C) 的GRM系列/DC200V或以上

☐ 接下页。

- GRM 系列
- GJM 系列
- GMA 系列
- GMD 系列
- GQM 系列
- GRJ 系列
- GR3 系列
- KRM 系列
- KR3 系列
- LLA 系列
- LLL 系列
- LLM 系列
- LLR 系列
- 警告

警告

☐ 接上页。

5. 直流电压和交流电压特性

1. 高介电常数型电容器的静电容量会随施加的交流电压而变化。

选择在直流电路中使用的电容器时，请考虑直流电压特性。

1-1. 陶瓷电容器的静电容量可能会随施加电压发生急剧变化。(参见图)

为了确保静电容量，请确认以下情况。

- (1) 施加电压引起的静电容量变化是否处于允许值范围内。
- (2) 在直流电压特性方面，静电容量变化率会随着电压增加而变得更大。即使施加电压低于额定电压，高介电常数类型电容器在需要静电容量变化小的电路中时，例如 时间常数电路，请仔细考虑电压特性，并仔细确认实际应用条件及实际系统下的不同特性。

[直流电压特性]

示例：X7R (R7) 特性0.1 μ F，额定电压 50VDC

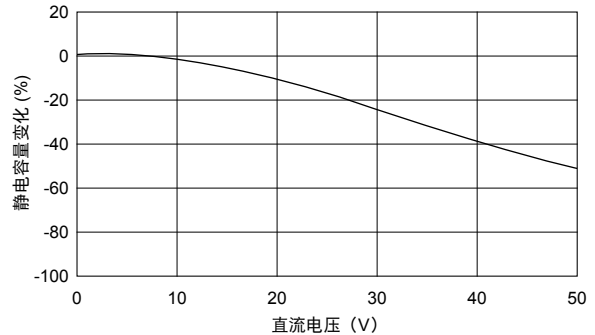

2. 高介电常数型电容器的静电容量会随施加的交流电压而变化。

选择在交流电路中使用的电容器时，请考虑交流电压特性。

[交流电压特性]

示例：X7R (R7) 特性10 μ F，额定电压6.3VDC

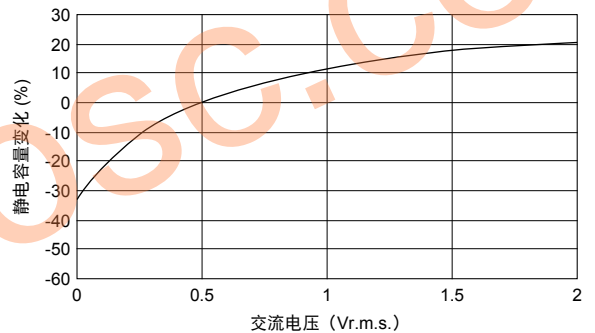

6. 电容老化

1. 高介电常数型电容器有一个特性，即静电容量会随时间推移而降低。

您在需要静电容量变化小的电路中使用高介电常数型电容器时，例如时间常数电路，请仔细考虑此类电容器的特性，例如其老化、电压和温度特性。并在预期环境和工作条件下使用实际设备测试电容器。

[随时间而变化的示例 (老化特性)]

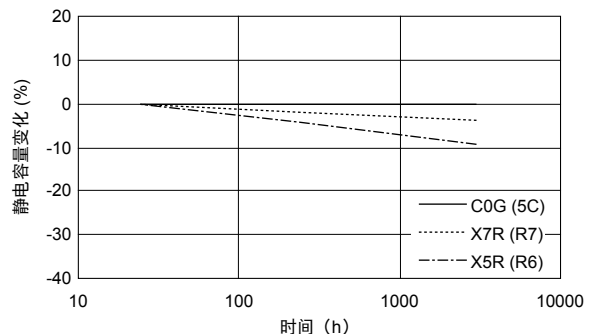

☐ 接下页。

GRM 系列

GJM 系列

GMA 系列

GMD 系列

GQM 系列

GRU 系列

GR3 系列

KRM 系列

KR3 系列

L1A 系列

L1L 系列

L1M 系列

L1R 系列

警告



☐ 接上页。

7. 振动和冲击

1. 请确认振动和/或冲击类型、条件和谐振产生。
请在安装电容器时避免产生谐振。不允许对端子产生任何影响。
2. 坠落形成的机械冲击可能会导致电容器的介质材料损坏或破裂。
切勿使用坠落后的电容器，因为其质量和可靠性可能已变差。
3. 印刷电路板堆放或搬运时，请勿用另一印刷电路板边角撞击电容器，以免造成电容器破裂或损坏。

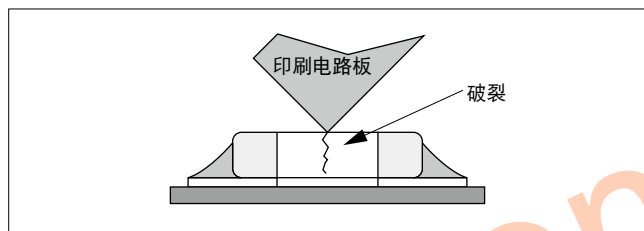
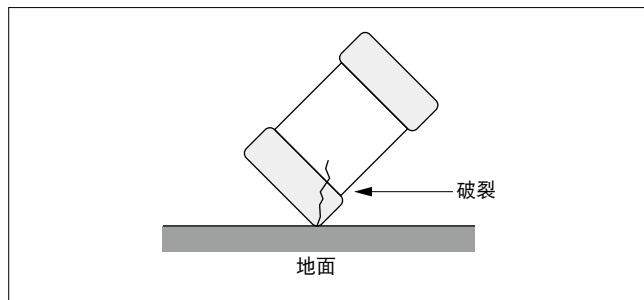

■ 焊接与贴装

1. 贴装位置

1. 应选择适当的贴装位置和方向，以使电路板弯折时施加在该电容器上的应力最小。
1-1. 请选择 PCB 弯曲或挠曲时贴片承受压力最小的位置进行安装。

[元件方向]

将贴片相对于压力作用方向水平放置。

[贴片贴装位置靠近 PCB 分离点]

必须采取以下预防措施来减少分离电路板时产生的应力。
最好采取以下全部三个措施；但应采取尽可能多的措施来降低应力。

措施内容	应力级
(1) 平行于电路板分离表面转动元件的贴装方向	A > D
(2) 在电路板分离处增加切口。	A > B
(3) 让元件的贴装位置远离电路板分离表面。	A > C

[在螺钉孔附近贴装电容器]

在螺钉孔附近贴装电容器时，其可能会受螺钉拧紧期间出现的电路板弯曲的影响。电容器的贴装位置要尽可能远离螺钉孔。

☐ 接下页。

GRM 系列

GUM 系列

GMA 系列

GMD 系列

GQM 系列

GRJ 系列

GR3 系列

KRM 系列

KP3 系列

LLA 系列

LLL 系列

LLM 系列

LLR 系列

警告

警告

☐ 接上页。

2. 贴装前信息

1. 切勿再次使用从设备上拆卸下的电容器。
2. 确认实际电压下的静电容量特性。
3. 确认实际过程中和设备使用下的机械应力。
4. 装配之前，确认额定静电容量、额定电压和其他电气特性。
5. 电容器经过长期存放后，使用前请确认其可焊性。
6. 电容器经过长期存放后，测量经典容量前需进行预热。
7. 使用Sn-Zn基焊料会严重影响MLCC的可靠性。
有关Sn-Zn基焊料的使用，请事先咨询村田的销售代表或产品工程师。
8. 对于贴装的预防措施，村田还制作了一张概括性列出了相关意见的DVD。请联系销售代表索取该DVD。

3. 贴装机（取放）的维护

1. 确保不向电容器施加以下过大的力量。
 - 1-1. 在印刷电路板上贴装电容器时，应保持施加最小的弯曲力，以防出现任何弯曲造成的损坏或破裂。使用过程中，请考虑以下预防措施和建议。
 - (1) 调节吸嘴的最低位置，以免弯曲印刷电路板。
 - (2) 贴装时将吸嘴压力调节在1N到3N的静载荷范围内。
2. 吸嘴与圆柱内壁之间沉积的尘土颗粒及粉尘会使吸嘴移动不畅。这会在贴装时对贴片施加较大的力量，从而导致贴片损坏。定位爪磨损后会在定位时对贴片用力不均，从而导致贴片破损。吸嘴及定位爪必须定期维修、检查更换。

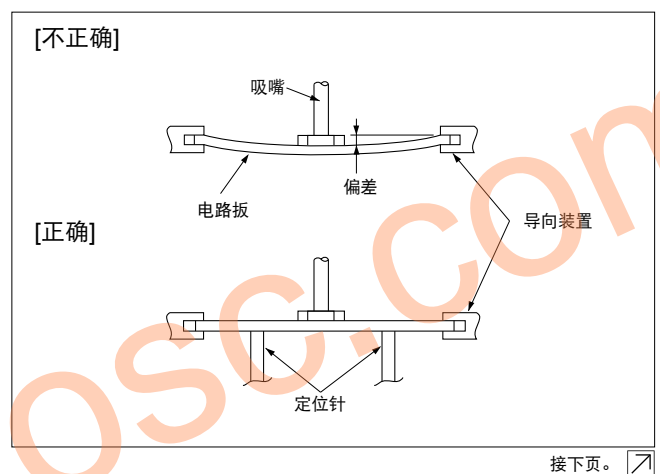



☐ 接上页。

4-1. 回流焊接

1. 如果元件突然受热，则会降低其机械强度。原因是较大的温度变化会导致内部变形。为防止造成机械损坏，应对元件和PCB板进行预热。

有关预热条件的说明，请参见表1。应尽可能地保持焊接温度与元件表面温度之间的温差 (ΔT)。

2. 当焊接温度低于锡的熔点时，贴片镀锡端子的可焊性将下降。使用之前请确认贴片镀锡电极的可焊性。

3. 当元件贴装后浸泡在溶剂时，务必将元件与溶剂之间的温差 (ΔT) 维持在表1所示的范围内。

表 1

品名	温差
GJM/GQM/GR3/GRJ/GRM/KRM/LLL/LLR 系列 02/03/15/18/21/31 尺寸 LLL 系列 1U 尺寸	$\Delta T \leq 190^\circ\text{C}$
GR3/GRJ/GRM/KR3/KRM 系列 32/43/55 尺寸 LLA/LLM 系列 18/21/31 尺寸 GQM 系列 22 尺寸	$\Delta T \leq 130^\circ\text{C}$

建议采用条件

	Pb-Sn 焊料		无铅焊料
	回流	蒸汽回流	
峰值温度	230 到 250°C	230 到 240°C	240 到 260°C
环境	空气	惰性溶剂的饱和蒸汽	空气或氮气

Pb-Sn 焊料: Sn-37Pb
 无铅焊料: Sn-3.0Ag-0.5Cu

[回流焊接的标准条件]

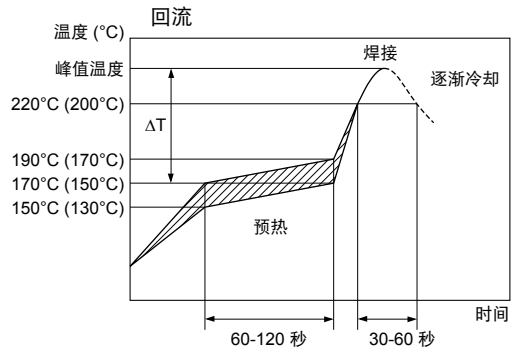

温度
 采用无铅焊料时
 () : 采用铅-锡焊料时

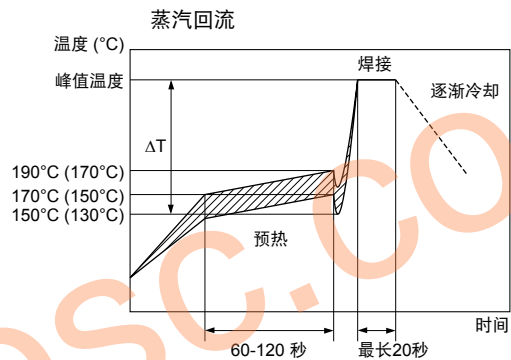

[允许回流焊接温度及时间]

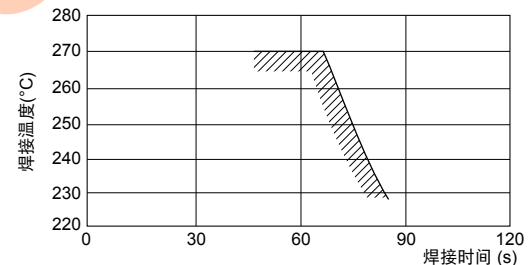

若是重复焊接，则累计焊接时间必须在以上所示的范围内。

4. 回流焊接的最佳焊料用量

4-1. 使用的锡膏过厚会导致焊接圆角偏高。

这会使PCB上的贴片更易受机械及热应力影响，而且可能导致贴片破损。

4-2. 锡膏太少会造成外部电极上结合强度不够，从而导致贴片从PCB上脱落。

4-3. 务必使锡膏均匀分布在端子表面上，厚度至少为 0.2mm*。

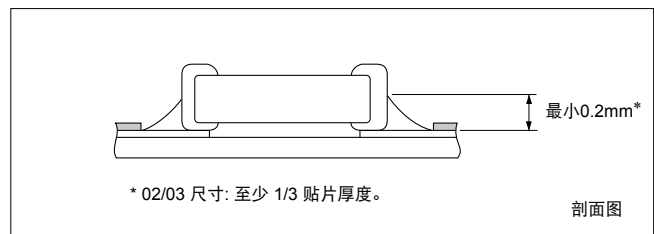

倒置PCB

勿使PCB承受异常机械冲击。

接下页。☐

警告

☑ 接上页。

4-2. 波峰焊接

1. 请勿对表2未列出的贴片进行波峰焊接。

表 2

品名	温差
GR3/GRM 系列 18/21/31 尺寸 GQM 系列 18/21 尺寸 LLL 系列 21/31 尺寸 GRJ 系列额定电压 250VDC或大于 18/21/31 尺寸	$\Delta T \leq 150^{\circ}\text{C}$

2. 如果元件突然受热，则会降低其机械强度。原因是较大的温度变化会导致内部变形。为防止造成机械损坏，应对元件和PCB板进行预热。

有关预热条件的说明，请参见表2。应尽可能地保持焊接温度与元件表面温度之间的温差 (ΔT)。

3. 焊接时间过长或 温度 过高会造成外部电极浸析，从而会因电极与外部端子之间接触不良而导致结合不牢，或静电容量值降低。

4. 当元件贴装后浸泡在溶剂时，务必将元件与溶剂之间的温差 (ΔT) 维持在表2所示的范围内。

建议采用条件

	Pb-Sn 焊料	无铅焊料
预热峰值温度	90 到 110°C	100 到 120°C
焊接峰值温度	240 到 250°C	250 到 260°C
环境	空气	空气

Pb-Sn 焊料: Sn-37Pb

无铅焊料: Sn-3.0Ag-0.5Cu

5. 波峰焊接的最佳焊料用量

5-1. 焊接圆角顶部应低于在元件的厚度。如果焊料量过大，则在弯曲或其他应力条件下元件存在很大的断裂危险。

[波峰焊接的标准条件]

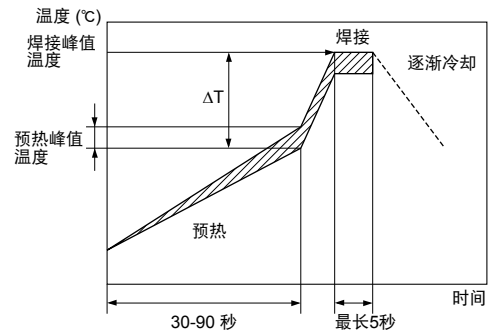

[允许波峰焊接温度及时间]

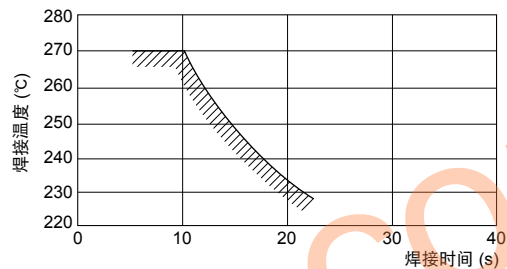

若是重复焊接，则累计焊接时间必须在以上所示的范围内。

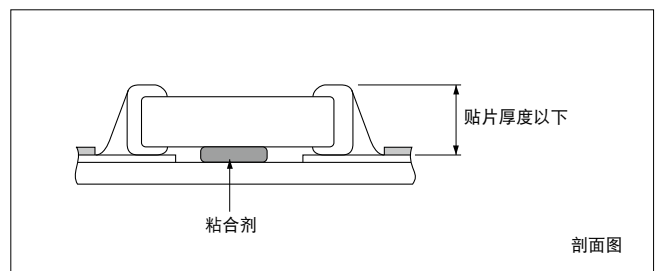

接下页。 ↗



☐ 接上页。

4-3. 焊接部分的校正

如果电容器突然受热，其内部会因较大的温差出现变形，且是引起破裂的原因。根据电路板预热温度或焊接圆角形状，电容器还会受机械应力和热应力的影响并出现破裂。关于焊料用量和圆角形状，请参阅“1. PCB 设计”或“3. 最佳焊料用量”。

1. 使用烙铁进行校正

- 1-1. 为降低对电容器的损坏，确保对电容器和贴装电路板板进行预热。预热温度范围如表3所示。可使用加热板型、热空气型预热器等来进行预热。
- 1-2. 焊接后，切勿使元件/PCB 快速冷却。
- 1-3. 尽快使用烙铁进行校正。如果烙铁使用时间过长，可能会导致端子电极上的焊料浸析，从而导致粘合强度降低及其他问题。

2. 使用热点加热器进行校正

- 与使用烙铁进行局部加热相比，热点加热器通过加热空气来加热整个元件和电路板，因此有助于降低热冲击。如为高密度贴装电路板，热点加热器还可避免烙铁直接接触元件这一问题。
- 2-1. 如热点加热器的热空气出口离元件的距离过近，可能会因为热冲击出现破裂。为避免这一问题，请遵从表4所示的条件。

- 2-1. 如热点加热器的热空气出口离元件的距离过近，可能会因为热冲击出现破裂。为避免这一问题，请遵从表4所示的条件。

3. 使用烙铁返修时的最佳焊料量

- 3-1. 如果尺寸小于 0603 (GJM/QQM/GR3/GRJ/GRM 系列, 03/15/18 尺寸)，那么焊料圆角的顶部应小于元件厚度的 2/3 或 0.5 mm，以较小者为准。如果尺寸为 0805 和更大尺寸 (GJM/QQM/GR3/GRJ/GRM 系列, 21/22/31/32/43/55 尺寸)，那么焊料圆角的顶部应小于元件厚度的 2/3。如果焊料量过大，则在弯曲或其他应力条件下存在很大的断裂危险。

表 3

品名	烙铁头温度	预热温度	温差 (ΔT)	环境
GJM/QQM/GR3/ GRJ/GRM 系列 03/15/18/21/31 尺寸	350°C 以下	150°C 以上	ΔT ≤ 190°C	空气
GRJ/GRM 系列 32/43/55 尺寸 GQM 系列 22 尺寸	280°C 以下	150°C 以上	ΔT ≤ 130°C	空气

*Pb-Sn 焊料和无铅焊料均可使用。
 Pb-Sn 焊料: Sn-37Pb
 无铅焊料: Sn-3.0Ag-0.5Cu

表 4

距离	5mm 或更大
热空气施加角度	45° *图1
喷嘴出口的热空气温度	400°C 以下
施加时间	少于 10 秒 (1206 (3216 (mm)) 尺寸或更小)
	少于 30 秒 (1210 (3225 (mm)) 尺寸或更大)

[图 1]

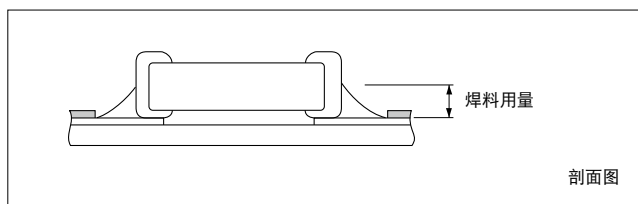
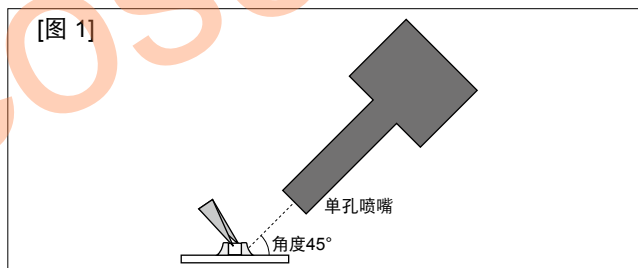

☐ 接下页。

警告

☑ 接上页。

3-2. 要求使用 $\phi 3\text{mm}$ 或更小直径的烙铁头。返修过程中需要防止烙铁直接接触元件。

3-3. 应使用 $\phi 0.5\text{mm}$ 或更细的焊条进行焊接。

<适用于KR3/KRM系列>

4. 关于烙铁头的形状，请参阅右图。

关于焊料类型，请使用 $\phi 0.5\text{mm}$ 或更小直径的焊丝（松香芯线焊料）。

4-1. 如何使用烙铁

将烙铁头抵近金属端子的下端使用。

1) 为防止陶瓷设备突然受热而形成破裂，请不要直接接触陶瓷基底。

2) 为防止贴片出现偏差和脱位，请不要直接接触贴片与金属端子的连接处以及外部的金属部分。

4-2. 最佳焊料用量

用烙铁校正的焊料用量应低于贴片较低一侧的高度。

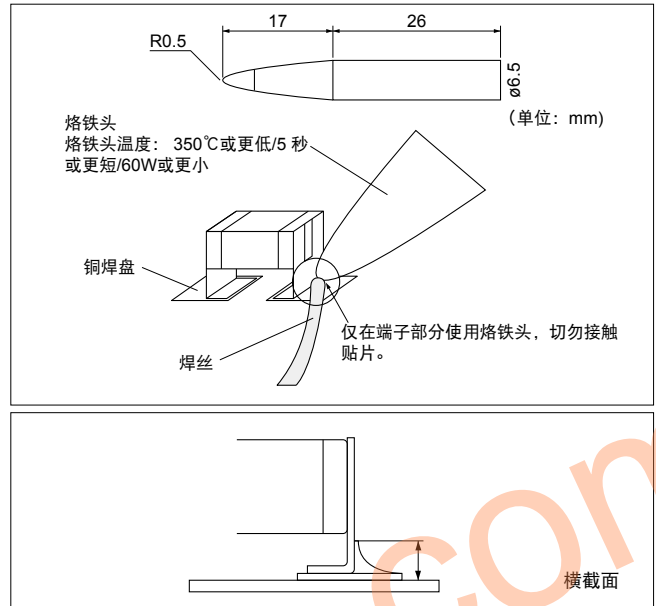

5. 清洗

清洗时若超声波振荡过大会导致PCB产生共振，从而造成贴片破损或焊缝开裂。请注意不要振动PCB。

6. 印刷电路板电气试验

1. 将电容器安装在印刷电路板后，检验电容器的电气性能时，确认定位针或专用夹具的位置。

1-1. 避免试验针等的压力弯曲印刷电路板。

测试探针的推力可使PCB发生弯曲，从而导致贴片破损或焊缝开裂。

请在PCB背面提供定位针，以免发生扭曲或弯曲。定位针尽量安装在靠近电容器的位置。

1-2. 试验针接触印刷电路板时，避免冲击引起的印刷电路板振动。

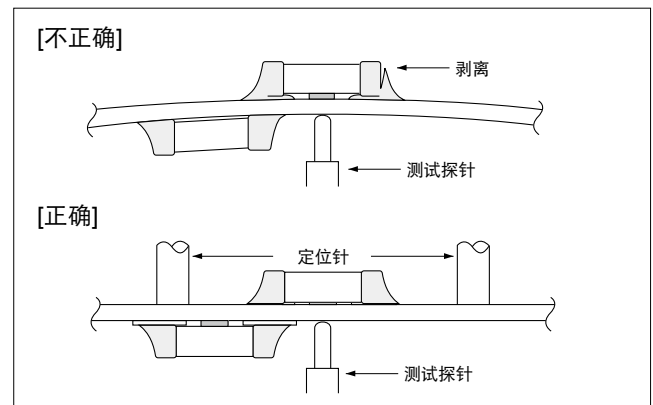

7. 印刷电路板裁切

1. 在印刷电路板上贴装电容器后，不要通过弯曲或扭曲该板向电容器施加任何应力。

1-1. 裁切该板时，右图所示弯曲或扭曲电路板可能会导致电容器断裂。

有断裂的电容器可能会导致绝缘电阻降低，从而出现短路。

避免向电容器施加这种类型的应力。

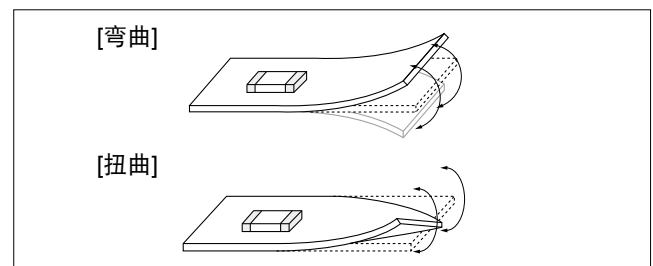

☑ 接下一页。



☐ 接上页。

2. 预先检查印刷电路板的裁切方法。

2-1. 应使用夹具或某种设备（圆刀分切机、刨刀式分切机等）进行印刷电路板裁切，以避免在电路板上出现机械应力。

电路板分切方法	手动分切夹钳分切	(1) 电路板分切夹具	电路板分切设备	
			(2) 圆刀分切机	(3) 刨刀式分切机
电路板上的应力水平	高	中	中	低
正确	×	△*	△*	○
注	手动夹钳分切施加较大的应力。使用其他方法。	<ul style="list-style-type: none"> · 电路板操作 · 电路板弯曲方向 · 电容器布局 	<ul style="list-style-type: none"> · 电路板操作 · 切口布局 · 形槽设计 · 刀片排列 · 控制刀片寿命 	电路板操作

*使用电路板分切夹具或圆刀分切机时，如不遵守以下预防措施，则会出现严重的电路板弯曲且电容器可能会出现破裂。如可能，请使用刨刀式分切机。

(1) 适当夹具示例

[如为单侧贴装]

电路板分切夹具的略图如下所示。正确示例：通过握住靠近夹具的部位并向贴装电容器一侧的方向弯曲可最大程度地降低元件贴装位置上的应力。不正确示例：如果握住距离夹具较远的部位并向贴装电容器的对立方向弯曲，则会增加电容器出现破裂的风险，原因在于元件贴装位置施加了较大的应力。

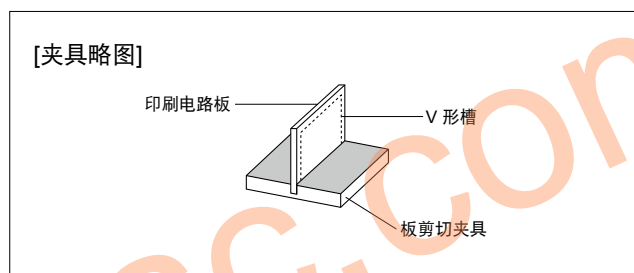

[如为双侧贴装]

由于元件贴装在电路板的两侧，使用上述方法无法避免出现破裂的风险。

因此，采取以下措施来避免在元件上施加应力。（测量）

- (1) 考虑使用刨刀式分切机。
如果不便使用刨刀式分切机，请采取以下措施。（请参阅第1条：贴装位置）
- (2) 将元件以合适的角度贴装在电路板分切表面。
- (3) 将元件贴装在电路板分切点附近时，在元件附近的分切点增加切口。
- (4) 使元件的贴装点远离电路板分切点。

☐ 接下页。

警告

☐ 接上页。

(2) 圆刀分切机示例

圆刀分切机的略图如下所示。如工作原理所示，顶部刀片和底部刀片与印刷电路板上的V形槽对齐，从而对电路板进行分切。

在以下情况下，将会施加电路板偏差应力并导致电容器出现破裂。

- (1) 顶部刀片和底部刀片调整后未对齐时，比如上下、左右或前后方向出现偏差
- (2) V形槽的角度过低，V形槽的深度过浅或V形槽的顶部和底部未对齐

如果V形槽过深，在搬运时电路板可能会断裂。在设计V形槽深度时请认真考虑电路板材料的强度。

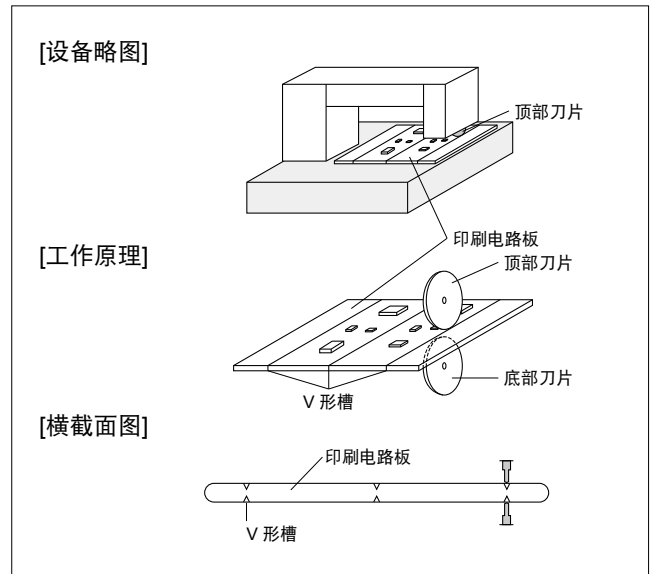

正确	不正确		
	上下偏离	左右偏离	前后偏离
<p>顶部刀片</p> <p>底部刀片</p>	<p>顶部刀片</p> <p>底部刀片</p>	<p>顶部刀片</p> <p>底部刀片</p>	<p>顶部刀片</p> <p>底部刀片</p>

推荐V形槽设计示例	不正确			
	左右偏离	角度过低	深度过浅	深度过深

(3) 刨刀式分切机示例

刨刀式分切机通过刨刀高速旋转进行切割。由于电路板在切割过程中不会弯曲，在对电路板进行分切时可抑制电路板上的应力。

在将电路板固定在刨刀式分切机上或从刨刀式分切机上取下电路板时，小心移动电路板，以避免弯曲。

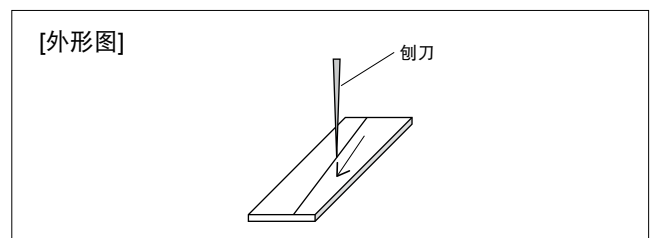

☐ 接下页。

GRM 系列
GJM 系列
GMA 系列
GMD 系列
GQM 系列
GRU 系列
GR3 系列
KRM 系列
KR3 系列
LLA 系列
LLL 系列
LLM 系列
LLR 系列



☐ 接上页。

8. 组装

1. 移动

如用一只手握住贴装有电容器的电路板，其可能会弯曲。
在移动时用双手紧紧握住电路板边缘。

如贴装有电容器的电路板掉落，则电容器上可能会出现断裂。

切勿使用坠落后的电路板，因为电容器的质量可能已变差。

2. 贴装其他元件

2-1. 贴装其他元件

将电容器贴装在对立侧后，在电路板的背面安装其他元件时，请注意以下情况。

吸嘴的下止点设置过低时，电路板弯曲应力可能会施加在背面（底部侧）的电容器上，且电容器上可能出现破裂。

- 电路板变直后，在电路板的上表面设置喷嘴的下止点。
- 定期检查并调节下止点。

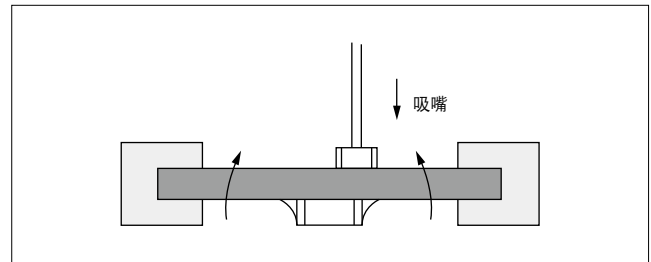

2-2. 将带引线的元件插在电路板上

将元件（变压器、IC等）插入电路板时电路板弯曲可导致电容器出现破裂或焊料出现断裂。

请注意以下情况。

- 增大用来插入引线的孔的尺寸，以降低插入期间施加在电路板上的应力。
- 插入之前，使用定位针或专用夹具固定电路板。
- 支撑住电路板的下方，使电路板不弯曲。在电路板上使用多个定位针时，定期确保每个定位针不存在高度差。



2-3. 安装/拆下插座

当电路板本身是一个连接器时，电路板在安装或拆下插座时可能会弯曲。对作业制订合理计划，使电路板在安装或拆下插座时不会弯曲。

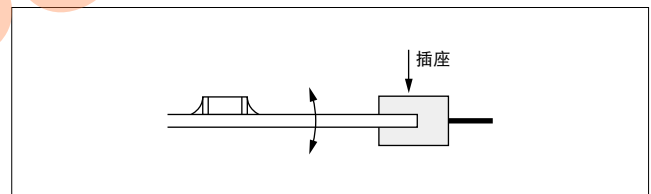

2-4. 拧紧螺钉

将电路板固定在外壳或底板期间拧紧螺钉时，电路板可能会弯曲。

在进行作业之前，请注意以下情况。

- 对作业制订合理计划，防止电路板弯曲。
- 使用扭矩螺丝刀，防止螺钉过度拧紧。
- 通过回流焊接等进行贴装后，电路板可能会弯曲。请注意在螺钉拧紧时，可能会因用力整平电路板导致应力施加在贴片上。

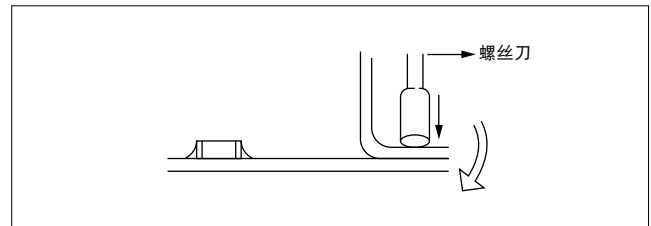

☐ 接下页。

GRM 系列

GJM 系列

GMA 系列

GMD 系列

GQM 系列

GRJ 系列

GR3 系列

KRM 系列

KR3 系列

LLA 系列

LLL 系列

LLM 系列

LLR 系列

警告

警告

☐ 接上页。

<适用于 GMA 或 GMD系列>

9. 元件结合 / 引线结合

1. 电容器的元件结合

1-1. 使用以下的铜焊合金材料: Au-Sn (80/20), 在300到320°C氮气环境下

1-2. 贴装

- (1) 控制好基板温度，使其与铜焊合金的温度一致。
- (2) 先将铜焊合金放在基板上，再在合金上放置电容器。请抓住电容器，轻轻用力。操作务必在1分钟内完成。

2. 引线结合

2-1. 引线

金线: 直径25 μ m (0.001英寸)

2-2. 结合

- (1) 热压、超声球焊。
- (2) 所需平台温度: 150到200°C
- (3) 所需力度: 0.2N到0.5N
- (4) 将电容器与基板或其他装置用金线结合。

■ 其他

1. 设备运行时

1-1. 设备运行期间，切勿用裸手直接接触设备运行期间，以免触电。

1-2. 切勿使电容器端子接触任何导电物体 (短路)。

切勿使电容器暴露于导电液体中，包括任何酸溶液或碱溶液。

1-3. 确认设备工作环境符合规定条件。

切勿在以下环境中使用该设备。

- (1) 飞溅到水或油。
- (2) 受阳光直射。
- (3) 暴露于臭氧、紫外线或辐射中。
- (4) 暴露于毒气 (例如 硫化氢、二氧化硫、氯气和氨气等) 环境中存放电容器。
- (5) 超过规定限制的任何振动或机械冲击。
- (6) 水气凝结环境。

1-4. 若在可能产生凝结的任何条件下使用，则需采用防潮措施。

2. 其他

2-1. 紧急情况下

(1) 如果设备产生烟雾、火灾或异味，应立即关闭设备或拔下设备插头。

如果未关闭设备或拔下设备插头，继续供电可能会造成更严重的危险。

(2) 在此类情况下，不允许脸和手接触电容器，否则会被电容器的高温灼伤。

2-2. 废物处置

处置电容器时，必须由具有适当执照的工业废物处理商进行焚烧或掩埋。

2-3. 电路设计

(1) 添加故障保护功能

因电路板掉落或弯曲而使导致电容器断裂可能会引起绝缘电阻降低，从而出现短路。

如在电容器短路时所用的电路可能会导致电击、冒烟或火灾，确保安装故障保护功能件，比如保险丝来防止二次事故。

(2) 用来在主交流实线电路中预防电磁干扰的电容器，或用作连接/绝缘层的电容器必须为安全规格认证产品，或符合电器和材料安全法规中规定的要求。每条线路上均安装保险丝，以防短路。

(3) GJM、GMA、GMD、GQM、GR3、GRJ、GRM、KR3、KRM、LLA、LLL、LLM 和LLR系列为非安全规格认证产品。

2-4. 备注

使用本产品时如忽略警告事项，则在严重情况下可能导致产品短路及冒烟。

以上注意事项针对标准用途及标准适用条件。如果产品用于特殊的贴装条件，请与我们联系。

请选择最佳的工作条件，这些条件的好坏可决定产品贴装后使用的可靠性。

本目录中的数据为典型值，并非保证额定值。

注意事项

■ 额定值

1. 工作温度

1. 工作温度限制视电容器而定。

1-1. 切勿应用于超过工作温度上限的温度。

需要选择能覆盖工作温度范围并具有适当额定温度的电容器。

同样必需考虑设备温度分布和季节温度变化因素。

1-2. 考虑电容器自发热

自发热因素计算在内时，电容器表面温度应为工作温度上限或略低。

2. 周围环境 (气体和液体)

1. 电容器工作环境限制。

1-1. 在上述不适当的环境中使用电容器时，由于端子腐蚀，水气渗入，电容器的性能可能会变差。

1-2. 电容器的电极或端子遭受水气凝结时，可能会出现上述相同现象。

1-3. 电容器长时间暴露于腐蚀性气体、挥发气体或溶剂时，端子电极氧化或腐蚀引起电容器的特性和绝缘阻抗变差，可能会导致电容器击穿。

3. 压电现象

1. 在交流电路或脉冲电路中使用高介电常数类型电容器时，在特定频率时电容器本身会振动，并可能会产生噪声。此外，电容器受到机械振动或冲击时，也可能产生噪声。

■ 焊接与贴装

1. PCB设计

1. 布局注意事项

1-1. 与引脚元件不同的是，片状元件由于直接贴装于基板上，因此易受弯曲应力影响。

而且它们对机械及热应力比引脚元件更敏感。

焊接圆角过高会加大此类应力，从而导致贴片破损。

因此在设计基板时，请考虑焊盘布局及尺寸，以免焊接圆角偏高。

1-2. 存在因印刷电路板热膨胀/收缩造成电容开裂的可能性，原因在于印刷电路板的材料和结构不相同导致贴片的应力也会不同。当用于贴装的电路板和电容之间的热膨胀系数差异较大时，会因为热膨胀和收缩导致贴片出现断裂。

当电容器贴装在氟树脂电路板或单层玻璃环氧树脂电路板上时，也会因相同的原因导致贴片出现断裂。

布局

	禁止	正确
靠近底盘放置		
放置片状元件和引线元件		
在片状元件之后，贴装引线元件		
横向贴装		

接下一页。

注意事项

☑ 接上页。

2. 焊盘尺寸

2-1. 如果焊盘面积过大，焊料使用过多，那么由于PCB弯曲等应力，片状电容器可能出现断裂。

关于波峰焊接 请参见表1的焊盘尺寸，关于回流焊请参见表2，关于LLA系列和LLM系列的回流焊请分别参阅表3和表4。

请通过评估实际SET/PCB确认适当的焊盘尺寸



表1 波峰焊接方式

品名	尺寸	贴片 (长X宽)	a	b	c
GQM/GR3/GRJ/GRM 系列 18 尺寸		1.6×0.8	0.6 到 1.0	0.8 到 0.9	0.6 到 0.8
GQM/GR3/GRJ/GRM 系列 21 尺寸		2.0×1.25	1.0 到 1.2	0.9 到 1.0	0.8 到 1.1
GR3/GRJ/GRM 系列 31 尺寸		3.2×1.6	2.2 到 2.6	1.0 到 1.1	1.0 到 1.4
LLL 系列 21 尺寸		1.25×2.0	0.4 到 0.7	0.5 到 0.7	1.4 到 1.8
LLL 系列 31 尺寸		1.6×3.2	0.6 到 1.0	0.8 到 0.9	2.6 到 2.8

波峰焊接仅可用于贴片尺寸为1.6x0.8mm 到 3.2x1.6mm 的产品。

(单位: mm)

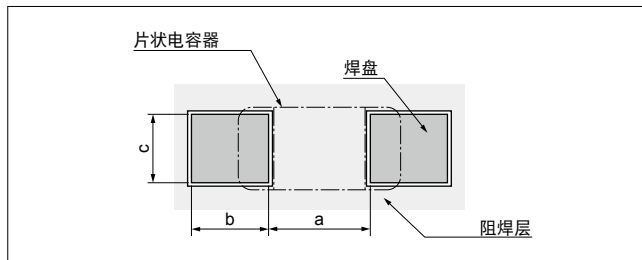
表2 回流焊接方法

品名	尺寸	贴片 (长X宽)	a	b	c
GJM/GRM 系列 02 尺寸		0.4×0.2	0.16 到 0.2	0.12 到 0.18	0.2 到 0.23
GJM/GRM 系列 03 尺寸		0.6×0.3	0.2 到 0.3	0.2 到 0.35	0.2 到 0.4
GJM/GRM 系列 15 尺寸		1.0×0.5 (±0.10内)	0.3 到 0.5	0.35 到 0.45	0.4 到 0.6
		1.0×0.5 (±0.15/±0.20)	0.4 到 0.6	0.4 到 0.5	0.5 到 0.7
GQM/GR3/GRJ/GRM 系列 18 尺寸		1.6×0.8 (±0.10内)	0.6 到 0.8	0.6 到 0.7	0.6 到 0.8
		1.6×0.8 (±0.15/±0.20)	0.7 到 0.9	0.7 到 0.8	0.8 到 1.0
GQM 系列 21 尺寸		2.0×1.25	1.0 到 1.2	0.6 到 0.7	0.8 到 1.1
GR3/GRJ/GRM 系列 21 尺寸		2.0×1.25 (±0.10内)	1.2	0.6	1.25
		2.0×1.25 (±0.15)	1.2	0.6 到 0.8	1.2 到 1.4
		2.0×1.25 (±0.20)	1.0 到 1.4	0.6 到 0.8	1.2 到 1.4
GR3/GRJ/GRM 系列 31 尺寸		3.2×1.6 (±0.20内)	1.8 到 2.0	0.9 到 1.2	1.5 到 1.7
		3.2×1.6 (±0.30)	1.9 到 2.1	1.0 到 1.3	1.7 到 1.9
GR3/GRJ/GRM 系列 32 尺寸		3.2×2.5	2.0 到 2.4	1.0 到 1.2	1.8 到 2.3
GR3/GRJ/GRM 系列 43 尺寸		4.5×3.2	3.0 到 3.5	1.2 到 1.4	2.3 到 3.0
GR3/GRJ/GRM 系列 55 尺寸		5.7×5.0	4.0 到 4.6	1.4 到 1.6	3.5 到 4.8
LLL 系列 15 尺寸		0.5×1.0	0.15 到 0.2	0.2 到 0.25	0.7 到 1.0
LLL 系列 1U 尺寸		0.6×1.0	0.20 到 0.25	0.25 到 0.35	0.7 到 1.0
LLL/LLR 系列 18 尺寸		0.8×1.6	0.2 到 0.3	0.3 到 0.4	1.4 到 1.6
LLL 系列 21 尺寸		1.25×2.0	0.4 到 0.5	0.4 到 0.5	1.4 到 1.8
LLL 系列 31 尺寸		1.6×3.2	0.6 到 0.8	0.6 到 0.7	2.6 到 2.8
GQM 系列 22 尺寸		2.8×2.8	2.2 到 2.5	0.8 到 1.0	1.9 到 2.3

(单位: mm)

<适用于品名KR3/KRM>

品名	尺寸	贴片 (长X宽)	a	b	c
KRM 系列 21 尺寸		2.0×1.25	1.0 到 1.2	0.6 到 0.7	0.8 到 1.1
KRM 系列 31 尺寸		3.2×1.6	2.2 到 2.4	0.8 到 0.9	1.0 到 1.4
KR3/KRM 系列 55 尺寸		5.7×5.0	2.6	2.7	5.6

(单位: mm)

接下页。☑

注意事项

☞ 接上页。



表 3 LLA 系列回流焊接方法

品名	尺寸	贴片 (长X宽)	a	b	c	p
LLA 系列 18 尺寸		1.6×0.8	0.3 到 0.4	0.25 到 0.35	0.15 到 0.25	0.4
LLA 系列 21 尺寸		2.0×1.25	0.5 到 0.7	0.35 到 0.6	0.2 到 0.3	0.5
LLA 系列 31 尺寸		3.2×1.6	0.7 到 0.9	0.4 到 0.7	0.3 到 0.4	0.8

(单位: mm)

表 4 LLA 系列回流焊接方法

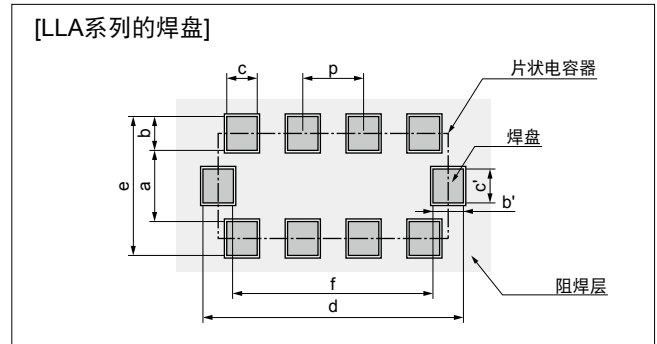
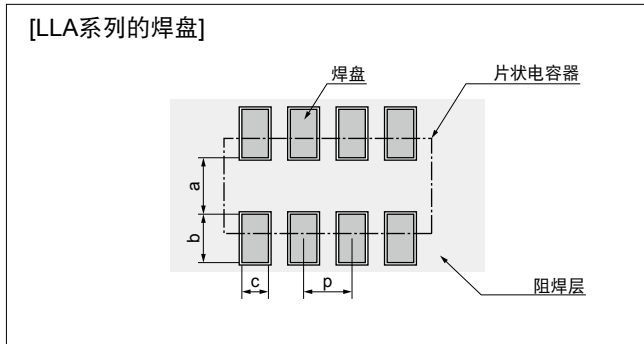
品名	尺寸	贴片 (长X宽)	a	b, b'	c, c'	d	e	f	p
LLM 系列 21 尺寸		2.0×1.25	0.6 到 0.8	(0.3 到 0.5)	0.3	2.0 到 2.6	1.3 到 1.8	1.4 到 1.6	0.5
LLM 系列 31 尺寸		3.2×1.6	1.0	(0.3 到 0.5)	0.4	3.2 到 3.6	1.6 到 2.0	2.6	0.8

$b=(c-e)/2, b'=(d-f)/2$

(单位: mm)

<适用于超过额定电压250VDC>

2-2. 切口尺寸 (示例)

开切口有助于在电容器背面进行助焊剂清洁和树脂涂抹等作业。

不过，切口设计的长度应尽可能短，以防止电容器出现机械损坏。

切口设计过长可能会承受来自印刷电路板过大的机械应力。

推荐的切口设计如右侧表格所示。

长X宽	d	e
1.6×0.8	-	-
2.0×1.25	-	-
3.2×1.6	1.0 到 2.0	3.2 到 3.7
3.2×2.5	1.0 到 2.0	4.1 到 4.6
4.5×2.0	1.0 到 2.8	3.6 到 4.1
4.5×3.2	1.0 到 2.8	4.8 到 5.3
5.7×2.8	1.0 到 4.0	4.4 到 4.9
5.7×5.0	1.0 到 4.0	6.6 到 7.1

(单位: mm)

☞ 接下页。

注意事项

☐ 接上页。

3. 电路板设计

设计电路板时，始终牢记出现的应力会随电路板的尺寸和材料而增大。

[应力值与电路板厚度、长度、宽度等的关系]

$$\varepsilon = \frac{3PL}{2Ewh^2}$$

负载和应力之间的关系

ε: 电路板中央的应力 (μst)
 L: 支撑点间的间距 (mm)
 w: 电路板宽度 (mm)
 h: 电路板厚度 (mm)
 E: 电路板的弹性模量 (N/m²=Pa)
 Y: 偏差 (mm)
 P: 负载 (N)

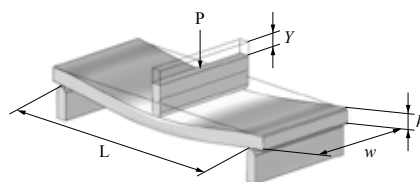

负载为常数时，以下关系成立：

- 支撑点间的间距 (L) 增大时，应力值也增大。
→ 减少支撑点间的间距。
 - 弹性模量 (E) 减小时，应力值增大。
→ 增大弹性模量。
 - 电路板宽度 (w) 减小时，应力值增大。
→ 增大电路板宽度。
 - 电路板厚度 (h) 减小时，应力值增大。
→ 增大电路板厚度。
- 由于电路板厚度为平方值，其对应应力值的影响会更大。

2. 粘合剂的使用

1. 粘合剂太薄或用量不足可能会导致贴片松脱，或在波峰焊接时断开。

粘合剂的用量应大于右图所示尺寸C，以达到足够的粘结强度。

贴片的电极厚度和焊盘厚度也必须考虑在内。

2. 低粘性粘合剂会导致贴片在贴装后滑动。粘合剂的粘性必须最少达到5000Pa·s (500ps)。 (25°C)。

3. 粘合剂使用量

尺寸 (长X宽) (单位: mm)	粘合剂使用量*
1.6×0.8	最少0.05mg
2.0×1.25	最少0.1mg
3.2×1.6	最少0.15mg

*标称值

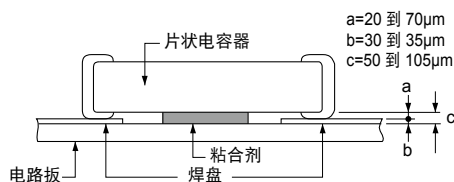

3. 粘合剂固化

1. 粘合剂固化不充分会导致贴片在波峰焊接时脱落，而且使外部电极之间因吸湿而造成绝缘电阻下降。

请控制好固化温度及时间以免固化不充分。

☐ 接下一页。

注意事项

☐ 接上页。

4. 回流和波峰焊接的助焊剂

1. 助焊剂用量过大会产生大量的气体，从而导致可焊性降低，因此应在整个过程中均匀使用少量的助焊剂。（波峰焊接一般采用发泡系统）。
2. 助焊剂中卤化物含量太高可能会导致外部电极腐蚀，除非经过充分的清洗。使用最大卤化物含量为0.1%的助焊剂。

5. 波峰焊接

- 注意温度及时间，以确保外部电极的沥滤不会超过单个元件终端面积（即如右所示A-B-C-D面的全长）的25%，以及贴装在基板上时如下所示A-B的长度。

3. 请勿使用强酸性助焊剂。
4. 请勿使用水溶性助焊剂*。
（*水溶性助焊剂可定义为非树脂型助焊剂，包括水洗型和非水洗型助焊剂。）

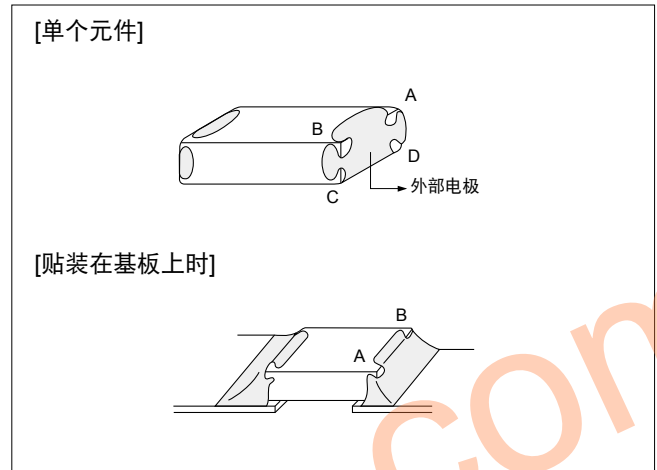

6. 清洗

1. 请通过实际清洁设备和确认质量的安全条件来评价电容器，然后选择适当的溶剂进行清洁。
2. 不适当的清洗溶剂可能会留下残留助焊剂和其他杂质，从而致使电容器的电气特性和可靠性变差。

3. 选择合适的清洗条件。
3-1. 不当清洗条件（过度或不足）可能会致使电容器性能变差。

7. 涂层

1. 固化处理过程中，树脂热收缩应力可能会致使电容器产生断裂。
这种应力受树脂量和固化收缩力的影响。
选择固化收缩小的树脂。
涂层树脂或成型树脂和电容器之间的热膨胀系数差异，可能会导致电容器损坏或变差，例如断裂或剥离，并导致绝缘阻抗变差或介质击穿。
选择热膨胀系数尽可能接近电容器热膨胀系数的树脂。
硅酮树脂可用作内涂层，以缓解应力。

2. 选择吸湿较少的树脂。
在高湿条件下使用吸湿树脂，可能会致使电容器绝缘阻抗变差。
所有环氧树脂都可用作吸湿较少的树脂。

接下页。 ☐

GRM 系列

GJM 系列

GMA 系列

GMD 系列

GQM 系列

GRJ 系列

GR3 系列

KRM 系列

KP3 系列

LLA 系列

LLL 系列

LLM 系列

LLR 系列

注意事项

注意事项

接上页。

■ 其他

1. 运输

1. 运输过程中的各种条件都可能会影响到电容器的性能。

1-1. 运输过程中电容器应该防止超温、湿气和机械力。

(1) 气候条件

- 低空气温度：-40°C
- 空气/空气温度变化：-25°C/+25°C
- 低气压：30 kPa
- 气压变化：6 kPa/min。

(2) 机械条件

运输应在外包装箱不变形，不受外部力量直接作用的方式下完成。

1-2. 切勿向电容器施加过度振动、冲击或压力。

(1) 向电容器施加过度机械振动或压力时，电容器陶瓷体可能会发生破碎或断裂。

(2) 空气驱动装置、烙铁、小钳和底盘等的锐边会强烈碰撞电容器表面时，电容器可能会断裂或短路。

1-3. 切勿使用因坠落受到过度冲击的电容器。

处理过程中意外坠落的电容器可能已损坏。

2. 实际系统中的特性评估

1. 使用之前，在实际系统中评估电容器，以确认成品的性能和规格值无任何问题。
2. 由于高介电常数型陶瓷电容器的电容具有电压依赖性和温度依赖性，电容可能会随实际系统的工作条件不同而有所变化。因此，确保评估各种会影响电容器电容值的特性，比如漏电流和啸叫吸收性。
3. 此外，超过预设浪涌的电压可能会通过实际系统的电感施加在电容器上。根据需要评估实际系统的浪涌电阻。

GRM 系列

GJM 系列

GMA 系列

GMD 系列

GQM 系列

GRU 系列

GR3 系列

KRM 系列

KR3 系列

LLA 系列

LLL 系列

LLM 系列

LLR 系列

注意事项

认证标准

本文中所列的产品由 ISO 9001 认证的工厂生产。

工厂
株式会社福井村田制作有限公司
株式会社出云村田制作有限公司
株式会社冈山村田制作有限公司
村田电子厂新加坡有限公司
北京村田电子有限公司
无锡村田电子有限公司

www.tocosc.com

设计辅助工具: SimSurfing SimSurfing

现在可使用 MLCC 了！

设计辅助工具“SimSurfing”已更新，现在您可查找 MLCC 的所有特性。

片状多层陶瓷电容器具有的功能：

- ① 产品搜索
- ② 查看频率特性 (S 参数, Z, R, X, Q, DF, L, C) 直流偏压可应用于现有的品名。
- ③ 直流电压偏压特性 (绝对电容/变化率)
- ④ 温度特性 (绝对电容/变化率)
- ⑤ 交流电压偏压特性 (绝对电容/变化率)
- ⑥ 下载 SPICE 网表 / S 参数



如果您注册成为工程师门户网站“my Murata”的会员，则您可使用增强版 SimSurfing。

会员注册
<https://my.murata.com/>

1 选择产品

(1) 按品名
(2) 按规格

1 (1) 按品名搜索

1 (2) 按规格搜索

2 查看特性

选中品名，点击此区域中的按钮，您可以查看任何电气特性曲线图。

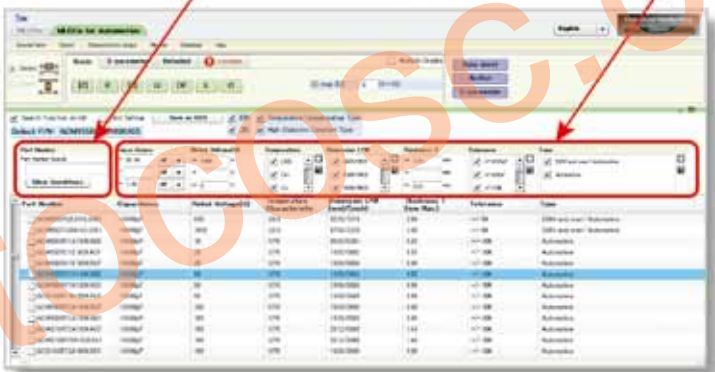

3 数据下载

您可下载 SPICE 网表和 S 参数文件 (S2P)

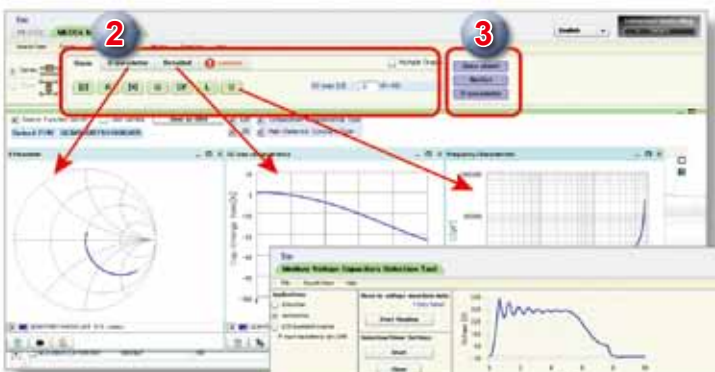

新增了电容器检索工具，以查找适用于指定电压波形的高压电容器。

这些图片于2014年8月拍摄。请确保经常升级该软件。

<http://ds.murata.com/software/simsurfing/en-us/mlcc/>

电容器网站介绍



Search for Capacitors

Global

Murata capacitors can be searched.

1 Search by part number

2 Search by specifications

3 Search by features

4 Search in the lineups

5 Cross reference

1 按品名搜索 <http://psearch.murata.com/capacitor/partnumber/>



尽管包装规格代码使用了替代符号“#”，您也可以输入整个包装规格代码来搜索含有包装规格代码的品名。

2 按规格搜索 <http://psearch.murata.com/capacitor/spec/>

可按各种规格，比如静电容量、额定电压和温度特性来搜索电容器。

基本规格

可按任何值及指定范围搜索适用产品。为支持搜索输入，适用于在其他条目中所选条件的产品最小值和最大值将显示。

添加更详细的规格

设定有关SMD、模制和引线型详细规格等特殊条件可让您按更详细的规格搜索电容器产品。

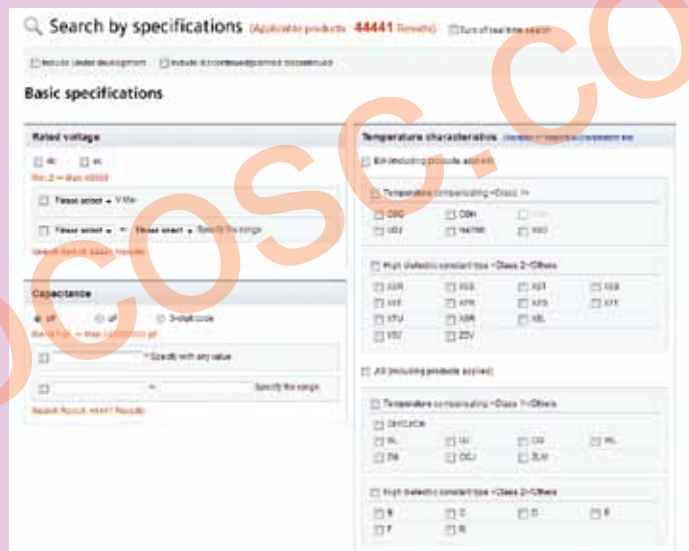

3 按产品特点搜索 <http://psearch.murata.com/capacitor/feature/>

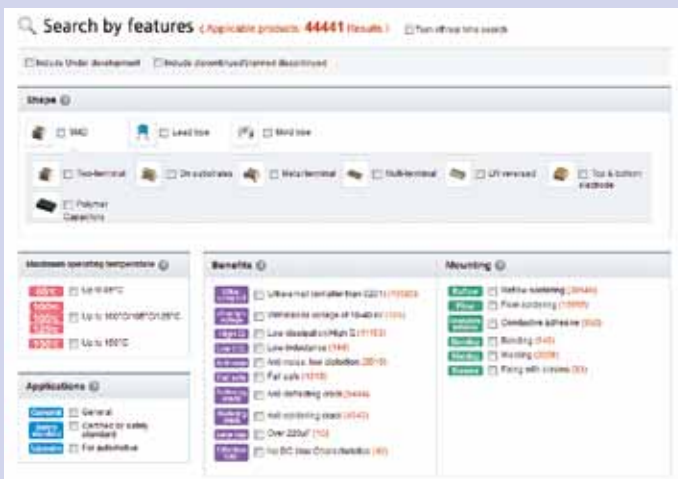

可按形状、最高使用温度、用途、产品优势和贴装方法来搜索适用电容器。

选择以下条目的条件来搜索产品。

- “形状”
- “最高使用温度”
- “用途”
- “产品优势”
- “贴装”

4 按产品一览搜索 <http://psearch.murata.com/capacitor/lineup/>

可从每种系列的产品一览中搜索符合条件的电容器。

还可在“系列”页面中查找系列的特点及用途。

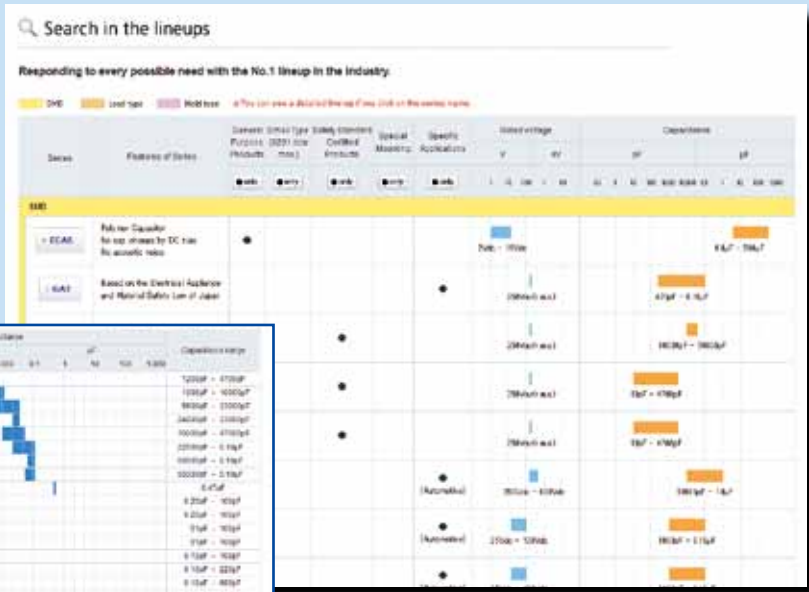

“系列”页面中的静电容量图表

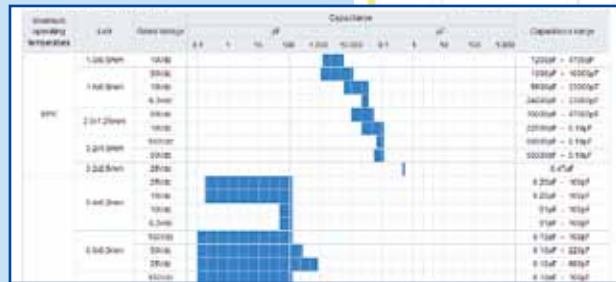

5 交叉参考搜索 <http://cross-reference.murata.com/capacitor/crossreference/index.cfm>

可按竞争对手的片状多层陶瓷电容器品名来搜索适合假定规格的村田品名。

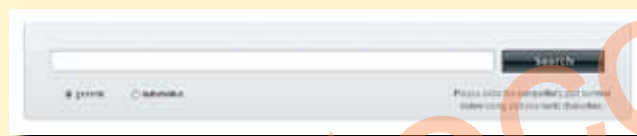

[搜索结果]

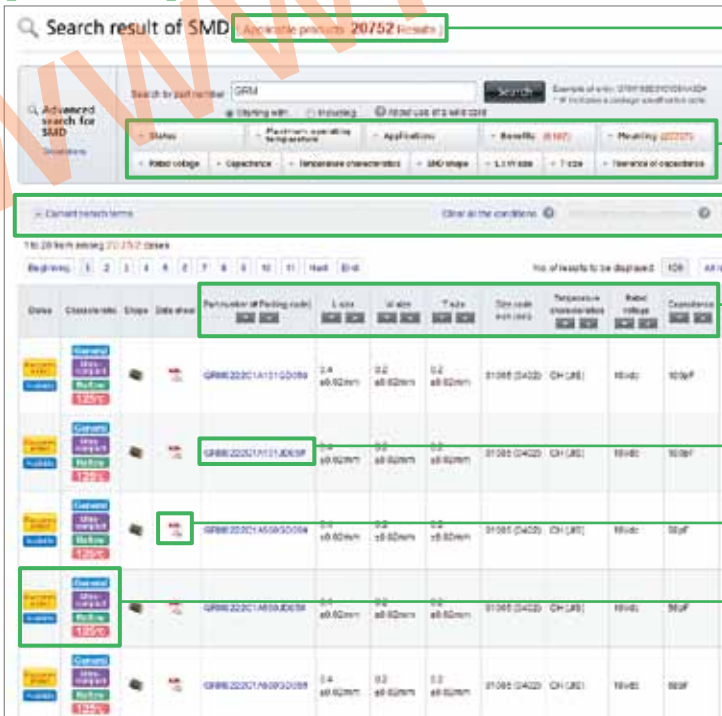

始终实时显示符合当前搜索条件的产品件数。

单击每个搜索条件按钮，显示菜单。搜索结果随所选条件实时变化。

单击“当前搜索条件”打开某条菜单，并可查看当前筛选条件。

可单击搜索结果项的▲按钮对结果进行排序。

单击产品名称将打开明细页面，同时可查阅更多详细信息。

无需打开明细页面便可下载单个规格表。

该图标清楚显示了产品的状态及特点。

全球分布

欲知更多详情请访问：www.murata.com.cn



△注：

1 出口管制

（对于日本国外客户）：

不应该通过任何渠道将村田产品用于或者销售给下列用途的设计、开发、生产、利用、维护保养或者运行，或者用作下列用途：（1）武器（大规模杀伤性武器（核武器、化学武器或生物武器或导弹）或常规武器），或者（2）专门为军事最终用途或军事最终用户的应用而设计的产品或系统。

（对于日本国内客户）：

根据日本“海外流通以及对外贸易管制法”（Foreign Exchange and Foreign Trade Law）受到管制的产品在出口时必须办理出口许可证。

2 若将本目录中的产品用于需要极高可靠性以防直接危及第三方生命、身体或财产的下列用途时，或当其中产品用于本目录规定以外的用途时，请提前与我公司销售代表或产品工程师联系。

- ① 飞行设备
- ② 宇航设备
- ③ 海底设备
- ④ 电厂设备
- ⑤ 医疗设备
- ⑥ 运输设备（汽车、火车、船舶等）
- ⑦ 交通信号设备
- ⑧ 防灾/预防犯罪设备
- ⑨ 数据处理设备
- ⑩ 与上述用途具有类似复杂性和（或）可靠性要求的其它用途

3 本目录中的产品规格以截止2014年8月的为准。规格若有变更，或若其中产品停产，恕不另行通知。请在订购之前向我公司销售代表或产品工程师查询。若有任何疑问，请与我公司销售代表或产品工程师联系。

4 请阅读本产品目录中的产品规格，以及相关保管、使用环境、规格上的注意事项、装配时的注意事项、使用时的注意事项的△注意事项，以免发生冒烟和（或）燃烧等。

5 本目录仅载明标准规格。因此，在订购产品之前，请核准其规格或者办理产品规格表。

6 请注意，对于使用我公司产品和（或）本产品目录中所述或记载的产品信息而发生有关我公司和（或）第三方知识产权及其它权利的冲突或争端，我公司概不负责，除非另有规定。由此而论，未经我公司许可，禁止自作主张将上述授权权利转授任何第三方。

7 我公司在生产过程中未使用蒙特利尔议定书（Montreal Protocol）规定的消耗臭氧层物质（ODS）。